

# SDA2 Series Servo System

## High Performance Purpose





## Company Profile

Savch Electric Co., Ltd was set up in Quanzhou, Fujian province in 2001 and established a research and development center in Shanghai. It is one of the first few companies to develop and produce motor drives in China. In 2005, it became China's top ten inverter brands. The company relies on a strong R & D team and world-class power electronics production and quality control system (OEM for top international brand) to provide customers with high-performance servo drives, inverters, computer controllers and other industrial control products.

The company focuses on the frontier technology fields of "industrial intelligence, energy saving, green energy", and adheres to the core goal of "creating value for customers", and establishes a technical R&D team that highly conforms to customer industry characteristics and highly integrated mechatronics and provide more efficient and resource-efficient system solutions for various industries customers. For the pass years, the company has established a global equal and close cooperation agent system, and customer service system with user satisfaction as an indicator, widely used in ceramics, packaging, textile, dyeing and finishing, engineering upgrading, lifting, road, CNC machine tools, glass, mining, petroleum, shipbuilding and other special industries.



SDA2 Series is a new high performance general purpose servo system (motor & drive), which can be widely used in a large industry, such as laser marking machine joint robot, linear mechanical hands, wood machinery, glass machinery, injection molding machinery, welding and cutting equipment, ceramic equipment, textile equipment, testing equipment, cable equipment, lithium battery equipment, electronic manufacturing equipment, milling machines, grinding machines, CNC lathes, food production lines, packaging production line, engraving and milling machine, engraving machine, high light machine, around line machine, warp knitting machine, labeling machine, veneer machines etc.

## High Performance

- Response frequency up to 1.2kHz
- Support 17/20bit encoder
- Max input/output pulse is 4Mpps
- Low cogging torque
- 3 times overload ability
- Analog command resolution is 16bit (optional)

## Intelligent

- Identification of Load Inertia
- Automatic/Manual Notch filter
- Real-time Automatic Gain Adjustment
- Automatic/Manual Vibration Suppression control

## Practical

- Friction Torque Compensation
- Input/Output Signal Assigned
- Gain switch
- Torque limit change
- Interrupt position control
- Built-in Regeneration resistance
- Electronic Cam Control
- Motor and drive miniaturization
- Gantry synchronization control
- Fully closed-loop control
- High flexibility internal location programming mode
- Support CANopen, EtherCAT<sup>™</sup> to realize multi-axis high response synchronization control

## Safe

- Safe Torque Off (STO) function (optional)
- Consideration for environment and Compliant with ROHS Directives, improve environmental performance
- Motor Enclosure Level with IP65/67, meet the waterproof and dustproof requirement

- This contents of catalog is only for selecting products models and types , when using a product, read the users' manual beforehand to use the product correctly.
- Products introduced in this catalog haven't been designed or manufactured for such applications in a system or equipment that will affect human bodies or lives clients, who want to use the products introduced in this catalog for special systems or device such as for military, aerospace and medical use, and traffic control are requested to consult SAVCH's Sales Center.
- Clients are requested to prepare safety measures when they apply the products introduced in this catalog to such systems or facilities that will affect human lives or cause severe damage to property if the products become faulty.



Safety  
Instructions

## Notch Filter (Auto-Notch Filter)

- When the mechanical resonance is detected, the notch filter will be automatically set.
- When the automatic notch filter is opened, it can carry out detection operation, so it can also deal with the time variation of the resonance frequency.

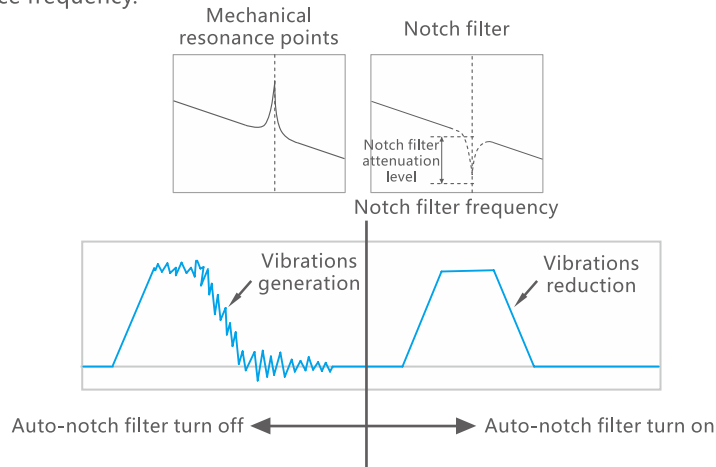

## Mechanical Vibration Suppression

- The standard is equipped with the newly designed vibration suppression control function, which can maximize the suppression of the vibration of machinery.
- It can solve the problem of vibration of the low rigidity machine in the front of the robot arm, and realize the stable operation of the machine.

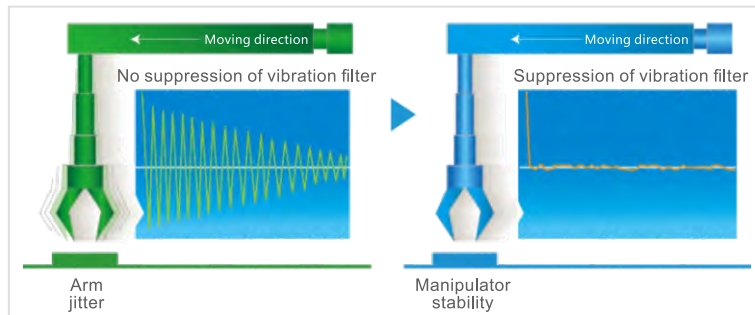

## New Auto-Tuning Function

- Newly designed auto-tuning function greatly improves the SDA2 auto-adaptive performance. Even the machine is with low rigidity, it can also carry on the most appropriate adjustment.

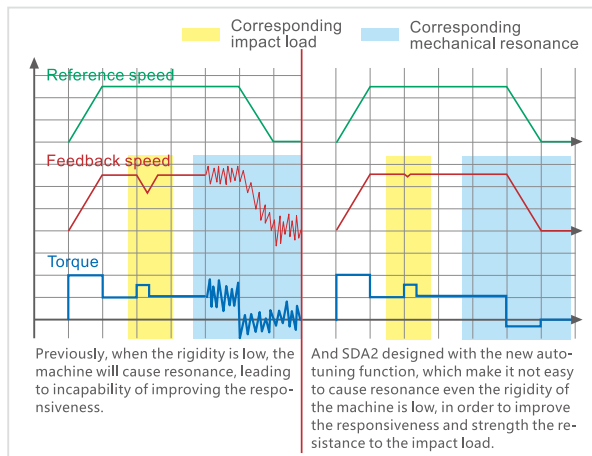

## High Precision Control

- Command pulse input and output feedback frequency are both up to 4Mpps and equip with 20bit incremental encoder, 1.04million for one round, which can realize the high precision positioning and make a more smooth operation and more stable during low speed operation.

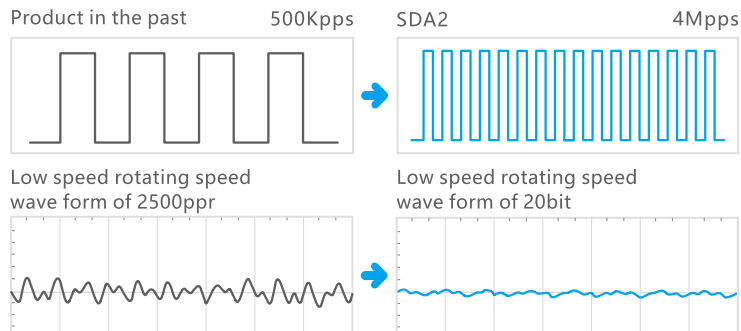

## Gantry Synchronization Control

- The two servos alternately sample the feedback position to adjust the motor speed in real time to achieve the purpose of dual-axis position synchronization, which is suitable for the gantry system.

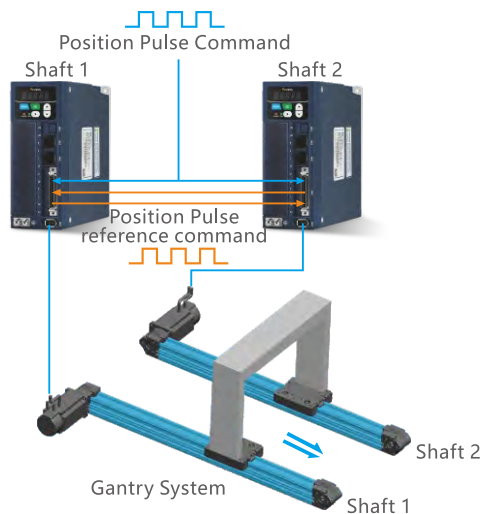

## Electronic Cam Control

- Electrically simulating the work of the mechanical cam can reduce the mechanical input, and can easily change the cam curve to achieve the purpose of eliminating the need to replace the mechanical cam and maintenance-free. It can be used for flying shears, chasing or other occasions requiring master-slave control.

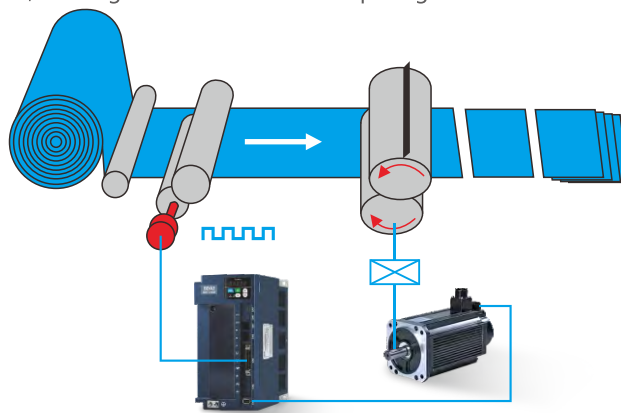

# System Structure Diagram

**【 No-Fuse Breaker (NFB) 】**

- ▶ To prevent the large instant current received by the power-on, power-off or the short circuit and damage the drive.

**【 Magnetic Contactor (MC) 】**

- ▶ When fault alarm was received, the servo drive could be used together to output alarm signal (ALARM) and control the contactor (MC), and stop the servo drive power supply

**【 Retrogradation Resistor Connected Externally 】**

- ▶ Optional

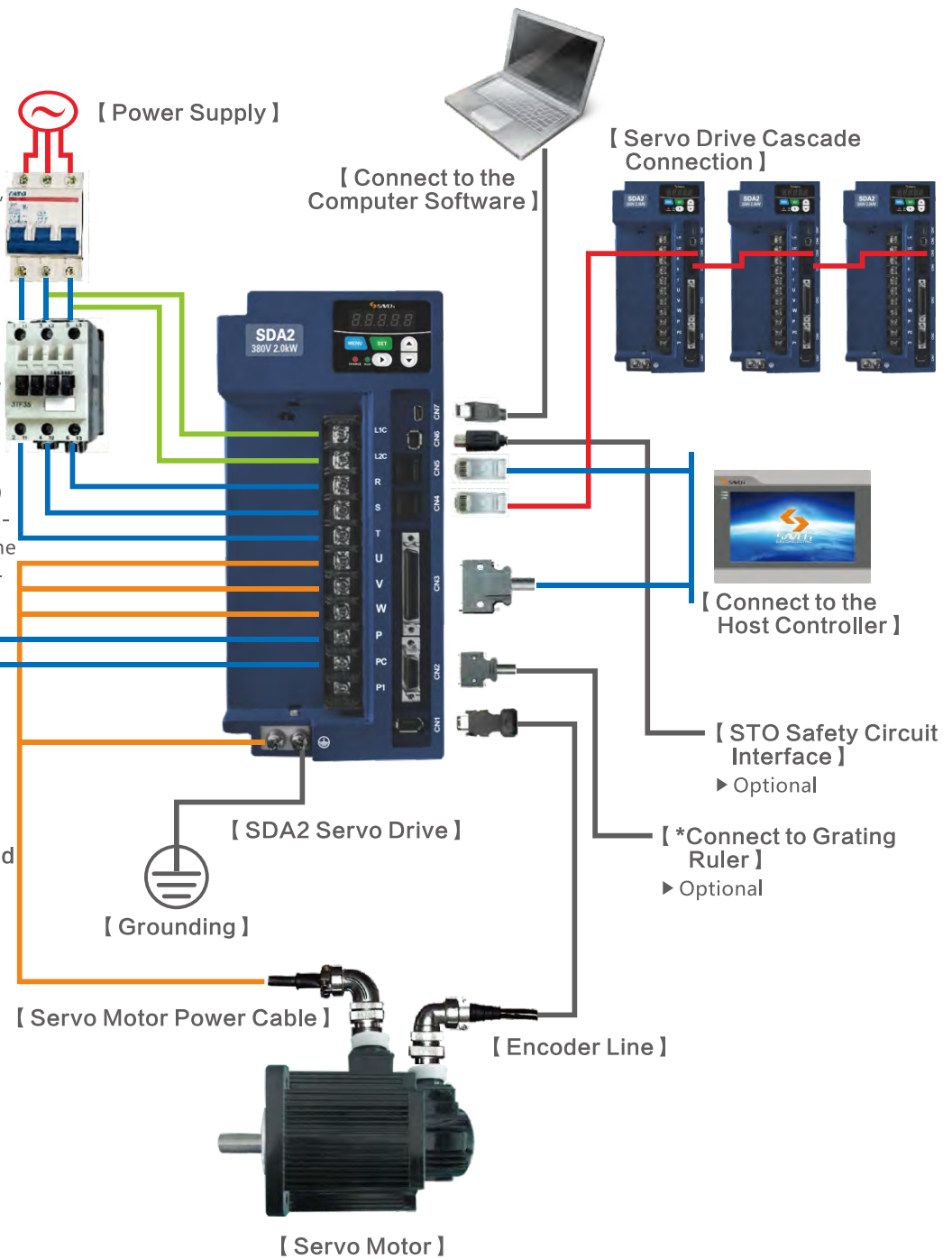

**Installation Notes:**

- Check the R, S, T and the L1C, L2C power supply and connecting wire
- Check the servo motor output U, V, W terminal phase wires (Unable to run when the connection is wrong)
- External connected retrogradation resistor is the selective spare, adopt according to the actual needs
- When fault or emergent stop was received, cut the power supply of magnetic contactor (MC) through ALARM output to stop the power supply of drive.
- \* indicates being developed

## Model Description

• Servo Motor

**SCH 130 202 C - 2 N D A 0 0 - A (5)**

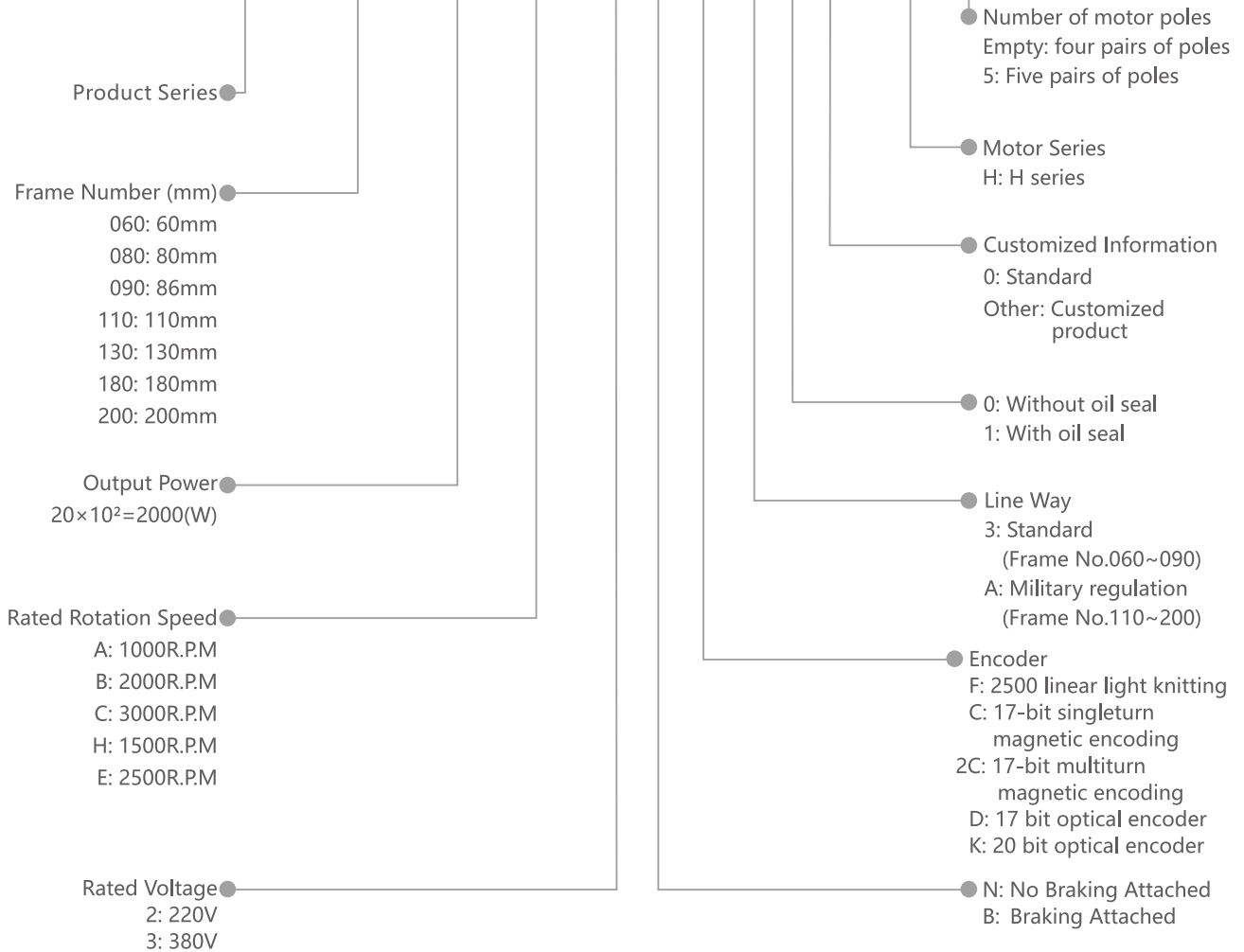

• Servo Drive

**SDA2 - 2T 2.0 G**

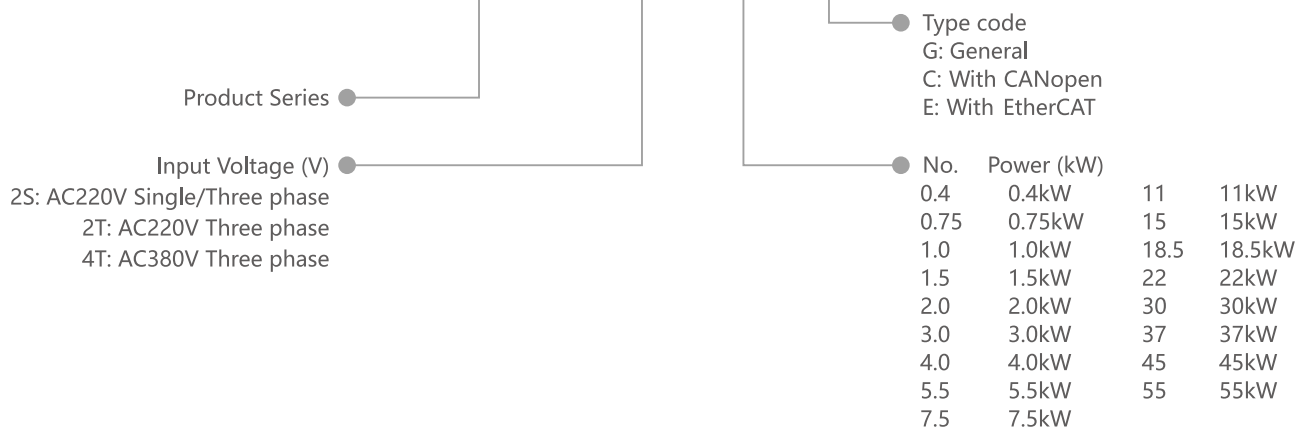

## Servo Drive Specification

### • Common Specifications

Item		Specifications
Input Power		Single/three phase 220V, three phase 380V
		Voltage variation range (-15%~+10%) 50/60Hz
Cooling Method		Fan cooling
Main Circuit Control Mode		IGBT PWM sine wave mode
Feedback		17-bit (standard) / 20-bit
Control Mode		①Position control ②Speed control ③ Torque control ④Position/speed mode switch ⑤Position/torque mode switch ⑥Speed/torque mode switch ⑦Positioning operation mode
Position Control	Max input pulse frequency	Low speed pulse: Max input 500kHz (Line drive input), Max input 200kHz (Open collector input) High Speed pulse: Max input 4MHz (Line drive input)
	Command pulse input mode	①Command pulse/command signal ②Forward rotating pulse and reverse rotating pulse ③A/B phase orthogonal pulse
	Command control mode	①External command pulse input control ②Internal position data control ③Communication command control
	Electronic gear	Electronic Gear N/M times (N:1~4194304)/(M:1~4194304)
	Torque limitation	Parameter control (Forward rotating and reverse rotating can be set respectively)/ External analog torque control
Speed Control	Analog command input	VREF DC0~±10V
	Speed variation rate	±1r/min or below (load range 0~100%)
	Speed range	1:5000
	Acceleration and deceleration time setting	Acceleration time and deceleration time can be set respectively, and have two groups, and can accelerate and decelerate with S curve
	Speed control mode	External analog input/Internal speed setting
Torque Control	Torque Limitation	Parameter control (Forward rotating and reverse rotating can be set respectively)/ External analog torque control
	Analog command input	TREF DC0~±10V
Digital Input/Output	Input	EI1~EI8 8 lines input, the function can be set freely according to the parameter
	Output	Encoder pulse outputs by frequency division, A/B/Z phase output by line drive and open collector (Total 6 lines) EOUT1~EOUT5 5 lines output, the function can be set freely according to the parameter
Monitor		Feedback speed, reference speed, reference torque, motor current, feedback of current location, Location Difference, reference pulse frequency, Feedback Pulse Accumulation, Reference Pulse Accumulation, VREF input voltage, TREF input voltage, input terminal signal, output terminal signal etc
Protection (Alarm display)		Overcurrent (oc1, oc2), Over speeding (oS), Overvoltage(Hv), Memory Error (dE), Encoder Error(Ec), Overload (oL1, oL2), Main circuit under voltage (Lu), EI Repeat (ctE), Deviation overflow (oF), Servo motor drive overheat (AH) etc.
Application Environment	Site location	Indoors (Avoid direct sunlight), No corrosive gas (Avoid smoke, methane)
	Ambient Temperature	0~50°C (When the ambient temperature is higher than the required one, please introduce air circulation)
	Storage Temperature	-20°C~75°C
	Relative humidity	RH 90% lower (No condensation)
	Altitude	Lower than 1000m
	Atmospheric pressure	86~106kPa
Vibration		≤0.5G

# Wiring Diagram

• Position Control Standard Wiring Diagram

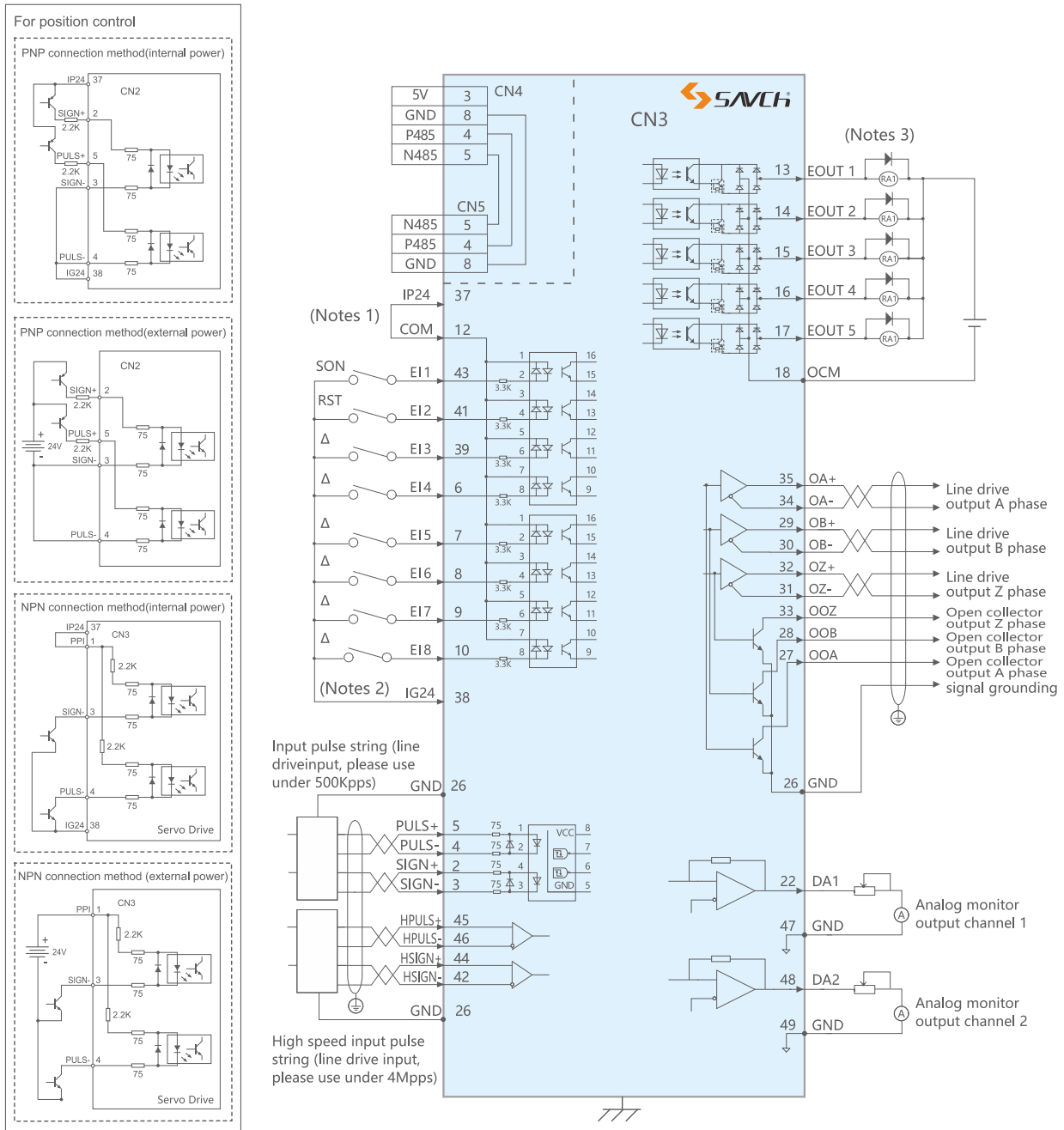

• Speed Control Standard Wiring Diagram

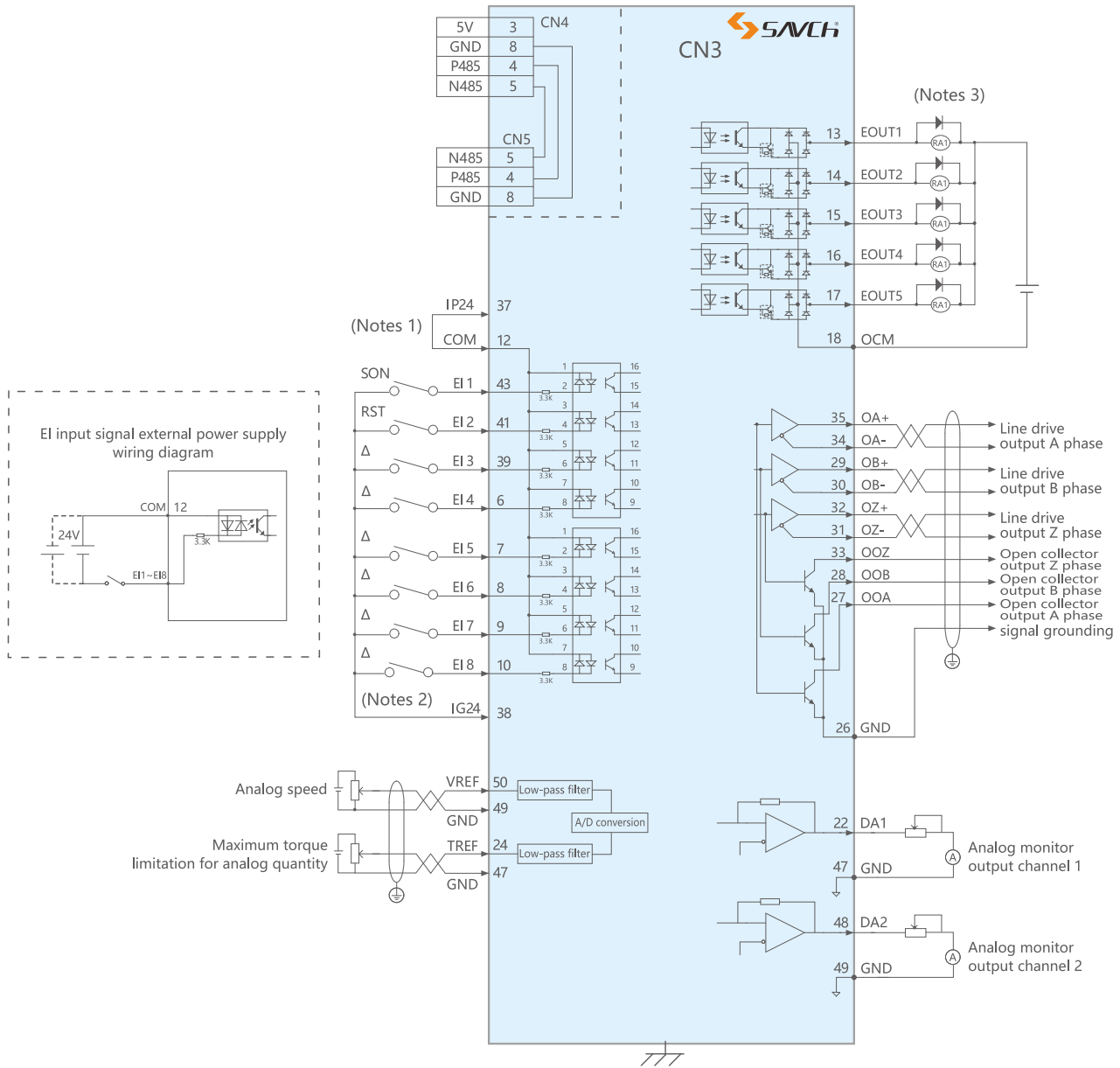

Wiring Diagram

- Notes 1: When the external power supply are adopted, do not connect the COM with IP24, external power supply 24V connected to COM.
- Notes 2: The EI input terminal that is marked Δ indicates that the initial function is not defined, user can set the required function according to the "User Manual".
- Notes 3: The diode installation direction could not be connected by the wrong way, max working voltage 24V, max output current 50mA; the current value of external relay ring should be lower than 80mA. When the current value is greater than 80mA, the power should be supplied externally.
- Notes: The above picture is the reference picture for the selected model, please read the manual and relevant wiring guidance carefully.

• Torque Control Standard Wiring Diagram

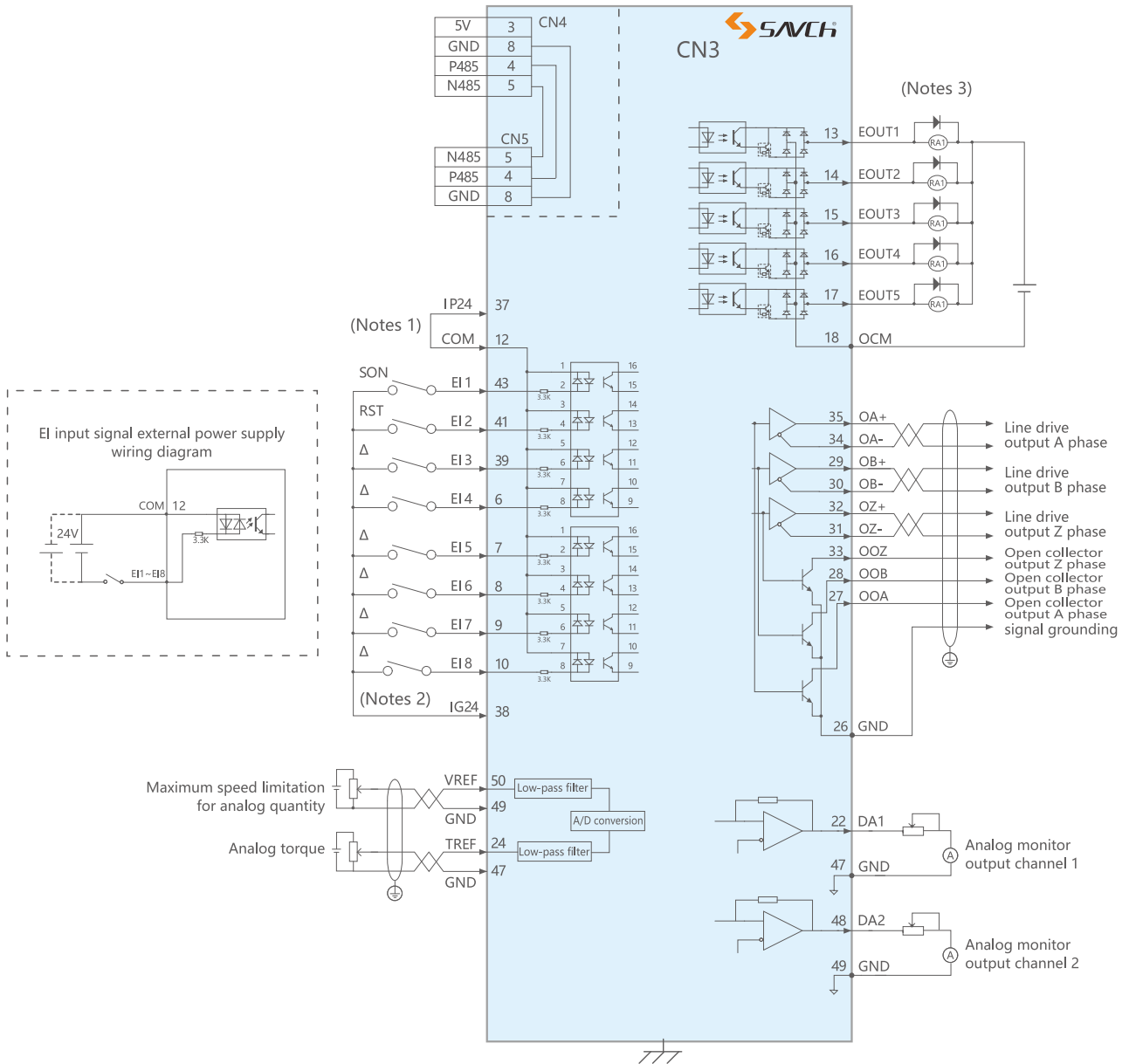

- Notes 1: When the external power supply are adopted, do not connect the COM with IP24, external power supply 24V connected to COM.
- Notes 2: The EI input terminal that is marked Δ indicates that the initial function is not defined, user can set the required function according to the "User Manual".
- Notes 3: The diode installation direction could not be connected by the wrong way, max working voltage 24V, max output current 50mA; the current value of external relay ring should be lower than 80mA. When the current value is greater than 80mA, the power should be supplied externally.
- Notes: The above picture is the reference picture for the selected model, please read the manual and relevant wiring guidance carefully.

# Servo Drive External Appearance

• Front View

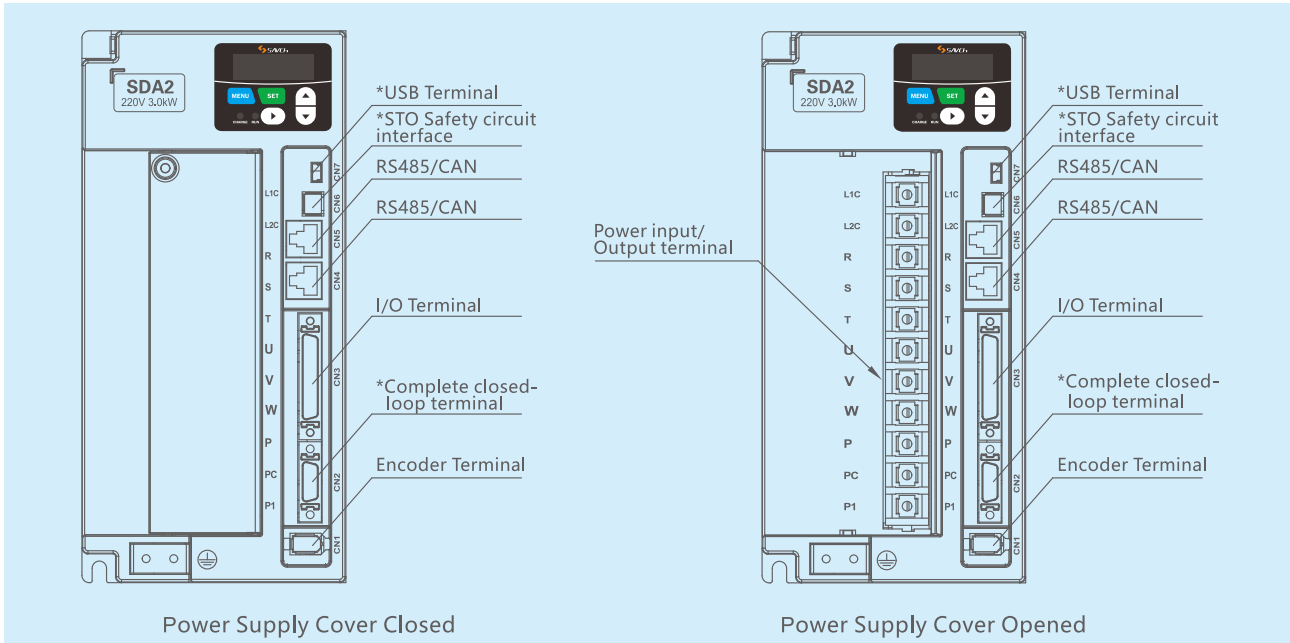

Note: \* indicates being developed

• Servo Drive External Dimension (Unit: mm)

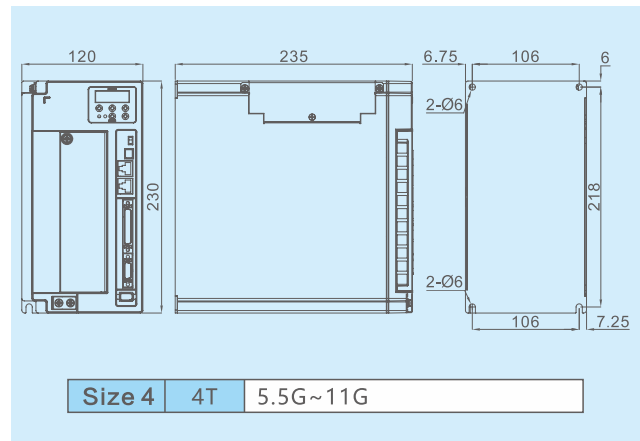
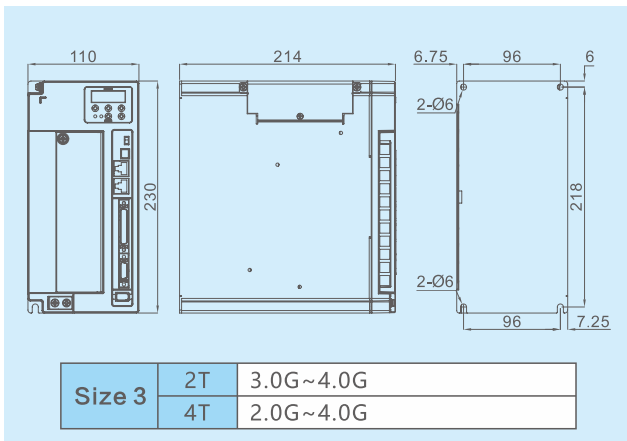
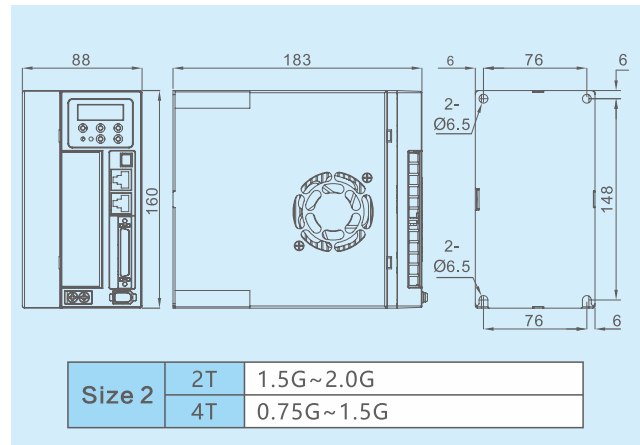
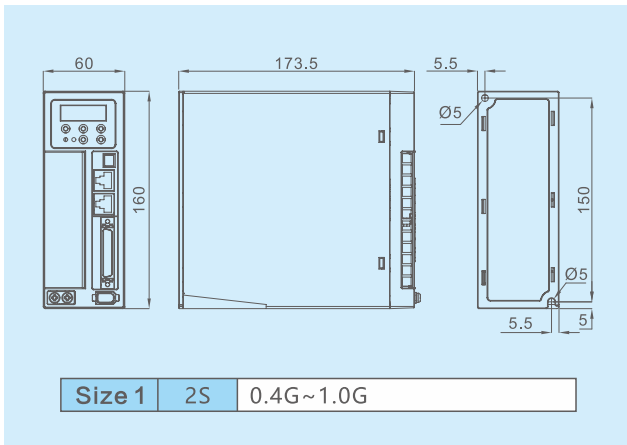

• Servo Drive External Dimension (Unit: mm)

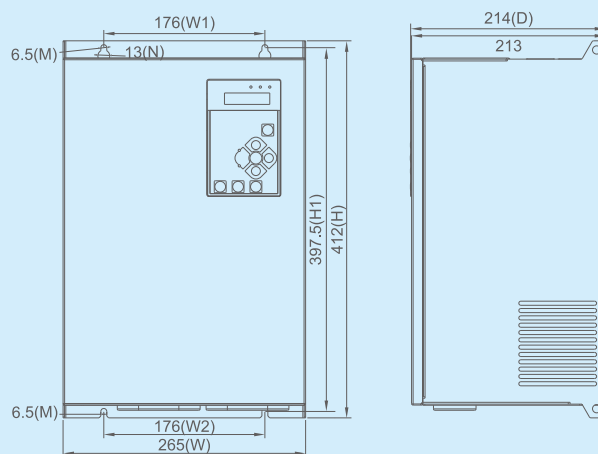

<b>Size 5</b>	<b>4T</b>	<b>15G~18.5G</b>
---------------	-----------	------------------

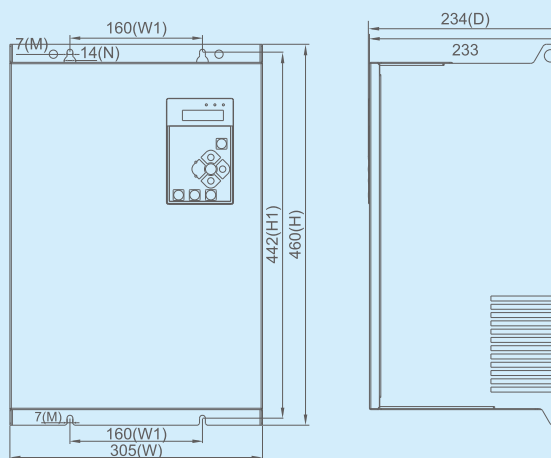

<b>Size 6</b>	<b>4T</b>	<b>22G</b>
---------------	-----------	------------

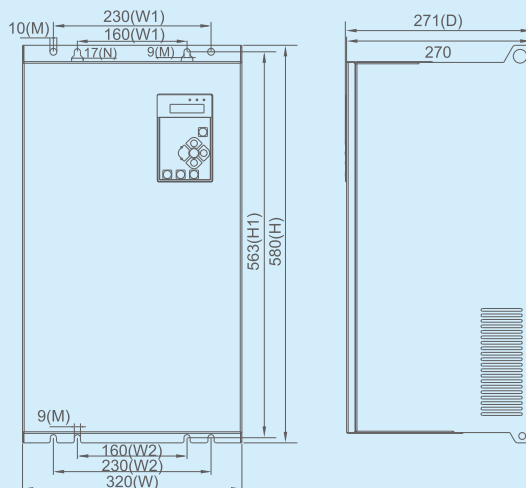

<b>Size 7</b>	<b>4T</b>	<b>30G~55G</b>
---------------	-----------	----------------

## Servo Motor Specification

- H series 220V
  - 60mm Series

Item	Servo Motor Model	
	SCH060201C	SCH060401C
Rated Output Power (W)	200	400
Applicable Servo Motor Driver	SDA2-2S0.4G	SDA2-2S0.4G
Rated Torque (N·m)	0.64	1.27
Rated Rotation Speed (R.P.M.)	3000	3000
Rated Current (A)	1.8	2.6
Rotor Inertia (kg·m <sup>2</sup> ×10 <sup>-4</sup> )	0.264	0.407
Instant Max Torque (N·m)	1.91	3.81
Max Rotation Speed (R.P.M.)	3600	3600
Weight (kg)	1.2	1.6
Insulation Level	F Class (155°C)	
Servo motor Ambient Temperature	-20°C~+40°C	
Permanent magnet brake	Brake Rated Voltage (V)	DC24±10%
	Brake Static Friction Torque (N·m)	2
	Brake Rated Power (W)	11

- H5 series 220V
  - 60mm Series

Item	Servo Motor Model	
	SCH060201C-□5	SCH060401C-□5
Rated Output Power (W)	200	400
Applicable Servo Motor Driver	SDA2-2S0.4G	SDA2-2S0.4G
Rated Torque (N·m)	0.64	1.27
Rated Rotation Speed (R.P.M.)	3000	3000
Rated Current (A)	1.6	2.6
Rotor Inertia (kg·m <sup>2</sup> ×10 <sup>-4</sup> )	0.28	0.52
Instant Max Torque (N·m)	1.92	3.81
Max Rotation Speed (R.P.M.)	6000	6000
Weight (kg)	0.8	1.1
Number of pole pairs	5	
Insulation Level	F Class (155°C)	
Servo motor Ambient Temperature	-20°C~+40°C	

- H series 220V
  - 80mm Series

Item	Servo Motor Model		
	SCH080751C	SCH080731B	SCH080102E
Rated Output Power (W)	750	730	1000
Applicable Servo Motor Driver	SDA2-2S0.75G	SDA2-2S0.75G	SDA2-2S1.0G
Rated Torque (N-m)	2.39	3.5	4
Rated Rotation Speed (R.P.M.)	3000	2000	2500
Rated Current (A)	3	3	4.4
Rotor Inertia (kg·m <sup>2</sup> ×10)	1.82	2.63	2.97
Instant Max Torque (N-m)	7.1	10.5	12
Max Rotation Speed (R.P.M.)	3600	2400	3000
Weight (kg)	2.9	3.9	4.1
Insulation Level	F Class (155°C)		
Servo motor Ambient Temperature	-20°C~+40°C		
Magnetic brake	Brake Rated Voltage (V)	DC24±10%	
	Brake Static Friction Torque (N-m)	4	
	Brake Rated Power (W)	18	

- H5 series 220V
  - 80mm Series

Item	Servo Motor Model
	SCH080751C-□5
Rated Output Power (W)	750
Applicable Servo Motor Driver	SDA2-2S0.75G
Rated Torque (N-m)	2.39
Rated Rotation Speed (R.P.M.)	3000
Rated Current (A)	4.5
Rotor Inertia (kg·m <sup>2</sup> ×10 <sup>-4</sup> )	2
Instant Max Torque (N-m)	7.17
Max Rotation Speed (R.P.M.)	6000
Weight (kg)	2.1
Insulation Level	F Class (155°C)
Servo motor Ambient Temperature	-20°C~+40°C

- H series 220V
  - 110 mm Series

Item	Servo Motor Model			
	SCH110122C	SCH110152C	SCH110122B	SCH110182C
Rated Output Power (W)	1200	1500	1200	1800
Applicable Servo Motor Driver	SDA2-2S1.0G	SDA2-2T1.5G	SDA2-2S1.0G	SDA2-2T1.5G
Rated Torque (N-m)	4	5	6	6
Rated Rotation Speed (R.P.M.)	3000	3000	2000	3000
Rated Current (A)	5	6	4.5	6
Rotor Inertia (kg·m <sup>2</sup> ×10 <sup>-4</sup> )	5.4	6.3	7.6	7.6
Instant Max Torque (N-m)	12	15	12	18
Max Rotation Speed (R.P.M.)	3600	3600	2400	3600
Weight (kg)	6	6.8	7.9	7.9
Insulation Level	F Class (155°C)			
Servo motor Ambient Temperature	-20°C~+40°C			
Magnetic brake	Brake Rated Voltage (V)	DC24±10%		
	Brake Static Friction Torque (N-m)	8		
	Brake Rated Power (W)	15		

- 130mm Series

Item	Servo Motor Model			
	SCH130102E	SCH130132E	SCH130152E	SCH130202E
Rated Output Power (W)	1000	1300	1500	2000
Applicable Servo Motor Driver	SDA2-2S1.0G	SDA2-2S1.0G	SDA2-2T1.5G	SDA2-2T2.0G
Rated Torque (N-m)	4	5	6	7.7
Rated Rotation Speed (R.P.M.)	2500	2500	2500	2500
Rated Current (A)	4	5	6	7.5
Rotor Inertia (kg·m <sup>2</sup> ×10 <sup>-4</sup> )	8.5	10.6	12.6	15.3
Instant Max Torque (N-m)	12	15	18	22
Max Rotation Speed (R.P.M.)	3000	3000	3000	3000
Weight (kg)	6.2	6.6	7.4	8.3
Insulation Level	F Class (155°C)			
Servo motor Ambient Temperature	-20°C~+40°C			
Magnetic brake	Brake Rated Voltage (V)	DC24±10%		
	Brake Static Friction Torque (N-m)	8		
	Brake Rated Power (W)	15		

- H series 220V
  - 130mm Series

Item	Servo Motor Model				
	SCH130102A	SCH130152H	SCH130262E	SCH130232H	SCH130382E
Rated Output Power (W)	1000	1500	2600	2300	3800
Applicable Servo Motor Driver	SDA2-2S1.0G	SDA2-2T1.5G	SDA2-2T2.0G	SDA2-2T2.0G	SDA2-2T3.0G
Rated Torque (N·m)	10	10	10	15	15
Rated Rotation Speed (R.P.M.)	1000	1500	2500	1500	2500
Rated Current (A)	4.5	6	10	9.5	13.5
Rotor Inertia (kg·m <sup>2</sup> ×10 <sup>-4</sup> )	19.4	19.4	19.4	27.7	27.7
Instant Max Torque (N·m)	20	25	25	30	30
Max Rotation Speed (R.P.M.)	1200	1800	3000	1800	3000
Weight (kg)	10.2	10.2	9.1	12.6	11.8
Insulation Level	F Class (155°C)				
Servo motor Ambient Temperature	-20°C~+40°C				
Magnetic brake	Brake Rated Voltage (V)	DC24±10%			
	Brake Static Friction Torque (N·m)	16			
	Brake Rated Power (W)	25			

- H5 series 220V
  - 130mm Series

Item	Servo Motor Model			
	SCH130851H-□5	SCH130132H-□5	SCH130182H-□5	SCH130232H-□5
Rated Output Power (W)	850	1300	1800	2300
Applicable Servo Motor Driver	SDA2-2S1.0G	SDA2-2T1.0G	SDA2-2T1.5G	SDA2-2T2.0G
Rated Torque (N·m)	5.4	8.4	11.5	14.6
Rated Rotation Speed (R.P.M.)	1500	1500	1500	1500
Rated Current (A)	6.5	9.5	12.5	16.0
Rotor Inertia (kg·m <sup>2</sup> ×10 <sup>-4</sup> )	13.9	20.5	30.1	40.7
Instant Max Torque (N·m)	16.2	25.2	34.5	43.8
Max Rotation Speed (R.P.M.)	3000	3000	3000	3000
Weight (kg)	6.8	9.4	11.5	12.4
Insulation Level	F Class (155°C)			
Servo motor Ambient Temperature	-20°C~+40°C			

- H series 220V
  - 180mm Series

Item	Servo Motor Model		
	SCH180252H	SCH180302H	SCH180432H
Rated Output Power (W)	2500	3000	4300
Applicable Servo Motor Driver	SDA2-2T2.0G	SDA2-2T3.0G	SDA2-2T4.0G
Rated Torque (N·m)	17	19	27
Rated Rotation Speed (R.P.M.)	1500	1500	1500
Rated Current (A)	10	12	16
Rotor Inertia (kg·m <sup>2</sup> ×10 <sup>-4</sup> )	65	70	96.4
Instant Max Torque (N·m)	42	47	67
Max Rotation Speed (R.P.M.)	1800	1800	1800
Weight (kg)	19.5	20.5	25.5
Insulation Level	F Class (155°C)		
Servo motor Ambient Temperature	-20°C~+40°C		
Magnetic brake	Brake Rated Voltage (V)	DC24±10%	
	Brake Static Friction Torque (N·m)	30	
	Brake Rated Power (W)	35	

- H series 380V
  - 80mm Series

Item	Servo Motor Model		
	SCH080751C	SCH080731B	SCH080102E
Rated Output Power (W)	750	730	1000
Applicable Servo Motor Driver	SDA2-4T0.75G	SDA2-4T0.75G	SDA2-4T1.0G
Rated Torque (N·m)	2.39	3.5	4
Rated Rotation Speed (R.P.M.)	3000	2000	2500
Rated Current (A)	1.6	1.8	2.3
Rotor Inertia (kg·m <sup>2</sup> ×10 <sup>-4</sup> )	1.82	2.63	2.97
Instant Max Torque (N·m)	7.1	10.5	12
Max Rotation Speed (R.P.M.)	3600	2400	3000
Weight (kg)	2.9	3.9	4.1
Insulation Level	F Class (155°C)		
Servo motor Ambient Temperature	-20°C~+40°C		
Magnetic brake	Brake Rated Voltage (V)	DC24±10%	
	Brake Static Friction Torque (N·m)	4	
	Brake Rated Power (W)	18	

- H series 380V
  - 110mm Series

Item	Servo Motor Model			
	SCH110122C	SCH110152C	SCH110122B	SCH110182C
Rated Output Power (W)	1200	1500	1200	1800
Applicable Servo Motor Driver	SDA2-4T1.0G	SDA2-4T1.5G	SDA2-4T1.0G	SDA2-4T1.5G
Rated Torque (N·m)	4	5	6	6
Rated Rotation Speed (R.P.M.)	3000	3000	2000	3000
Rated Current (A)	3.0	4.5	3.0	4.5
Rotor Inertia (kg·m <sup>2</sup> ×10 <sup>-4</sup> )	5.4	6.3	7.6	7.6
Instant Max Torque (N·m)	12	15	12	18
Max Rotation Speed (R.P.M.)	3600	3600	2400	3600
Weight (kg)	6	6.8	7.9	7.9
Insulation Level	F Class (155°C)			
Servo motor Ambient Temperature	-20°C~+40°C			
Magnetic brake	Brake Rated Voltage (V)	DC24±10%		
	Brake Static Friction Torque (N·m)	8		
	Brake Rated Power (W)	15		

- 130mm Series

Item	Servo Motor Model			
	SCH130102E	SCH130132E	SCH130152E	SCH130202E
Rated Output Power (W)	1000	1300	1500	2000
Applicable Servo Motor Driver	SDA2-4T1.0G	SDA2-4T1.0G	SDA2-4T1.5G	SDA2-4T2.0G
Rated Torque (N·m)	4	5	6	7.7
Rated Rotation Speed (R.P.M.)	2500	2500	2500	2500
Rated Current (A)	2.6	3.0	4.0	4.7
Rotor Inertia (kg·m <sup>2</sup> ×10 <sup>-4</sup> )	8.5	10.6	12.6	15.3
Instant Max Torque (N·m)	12	15	18	22
Max Rotation Speed (R.P.M.)	3000	3000	3000	3000
Weight (kg)	7.7	8.2	8.9	10
Insulation Level	F Class (155°C)			
Servo motor Ambient Temperature	-20°C~+40°C			
Magnetic brake	Brake Rated Voltage (V)	DC24±10%		
	Brake Static Friction Torque (N·m)	8		
	Brake Rated Power (W)	15		

## ■ 130mm Series

Item	Servo Motor Model				
	SCH130102A	SCH130152H	SCH130262E	SCH130232H	SCH130382E
Rated Output Power (W)	1000	1500	2600	2300	3800
Applicable Servo Motor Driver	SDA2-4T1.0G	SDA2-4T1.5G	SDA2-4T2.0G	SDA2-4T2.0G	SDA2-4T4.0G
Rated Torque (N-m)	10	10	10	15	15
Rated Rotation Speed (R.P.M.)	1000	1500	2500	1500	2500
Rated Current (A)	2.5	3.5	6	5	8.8
Rotor Inertia (kg·m <sup>2</sup> ×10 <sup>-4</sup> )	19.4	19.4	19.4	27.7	27.7
Instant Max Torque (N-m)	20	25	25	30	30
Max Rotation Speed (R.P.M.)	1200	1800	3000	1800	3000
Weight (kg)	10.1	12.1	9.1	12.5	14.5
Insulation Level	F Class (155°C)				
Servo motor Ambient Temperature	-20°C~+40°C				
Magnetic brake	Brake Rated Voltage (V)	DC24±10%			
	Brake Static Friction Torque (N-m)	16			
	Brake Rated Power (W)	25			

## ■ 180mm Series

Item	Servo Motor Model				
	SCH180252H	SCH180302H	SCH180432H	SCH180552H	SCH180752H
Rated Output Power (W)	2500	3000	4300	5500	7500
Applicable Servo Motor Driver	SDA2-4T2.0G	SDA2-4T3.0G	SDA2-4T4.0G	SDA2-4T5.5G	SDA2-4T7.5G
Rated Torque (N-m)	17	19	27	35	48
Rated Rotation Speed (R.P.M.)	1500	1500	1500	1500	1500
Rated Current (A)	6.5	7.5	10	12	20
Rotor Inertia (kg·m <sup>2</sup> ×10 <sup>-4</sup> )	65	70	96.4	122.5	167.2
Instant Max Torque (N-m)	42	47	67	70	96
Max Rotation Speed (R.P.M.)	1800	1800	1800	1800	1800
Weight (kg)	19.5	20.5	25.5	30.5	40
Insulation Level	F Class (155°C)				
Servo motor Ambient Temperature	-20°C~+40°C				
Magnetic brake	Brake Rated Voltage (V)	DC24±10%			
	Brake Static Friction Torque (N-m)	30		50	
	Brake Rated Power (W)	35		45	

- H series 380V
  - 200mm Series

Item	Servo Motor Model		
	SCH200832H	SCH200113B	SCH200113H
Rated Output Power (kW)	8.3	11.1	11
Applicable Servo Motor Driver	SDA2-4T7.5G	SDA2-4T11G	SDA2-4T11G
Rated Torque (N·m)	53	53	70
Rated Rotation Speed (R.P.M.)	1500	2000	1500
Rated Current (A)	18	22	21
Rotor Inertia (kg·m <sup>2</sup> ×10 <sup>-4</sup> )	72	72	97.7
Weight (kg)	46	46	52
Insulation Level	F Class (155°C)		
Enclosure	IP54		
Cooling method	Fan cooling		

- 200mm Series

Item	Servo Motor Model		
	SCH200133H	SCH200153B	SCH200183B
Rated Output Power (kW)	13	15	18
Applicable Servo Motor Driver	SDA2-4T11G	SDA2-4T15G	SDA2-4T18.5G
Rated Torque (N·m)	84	70	84
Rated Rotation Speed (R.P.M.)	1500	2000	2000
Rated Current (A)	23	28	32
Rotor Inertia (kg·m <sup>2</sup> ×10 <sup>-4</sup> )	114	97	114
Weight (kg)	59	52	59
Insulation Level	F Class (155°C)		
Enclosure	IP54		
Cooling method	Fan cooling		

- H series 380V
  - 230mm Series

Item	Servo Motor Model		
	SCH230233H	SCH230293H	SCH230353H
Rated Output Power (kW)	23	29	35
Applicable Servo Motor Driver	SDA2-4T22G	SDA2-4T30G	SDA2-4T37G
Rated Torque (N·m)	149	185	223
Rated Rotation Speed (R.P.M.)	1500	1500	1500
Rated Current (A)	54	65.5	79
Rotor Inertia (kg·m <sup>2</sup> ×10 <sup>-4</sup> )	145	620	740
Insulation Level	F Class (155°C)		
Enclosure	IP54		
Cooling method	Fan cooling		

- 260mm Series

Item	Servo Motor Model	
	SCH260383H	SCH260453H
Rated Output Power (kW)	38	45
Applicable Servo Motor Driver	SDA2-4T30G	SDA2-4T45G
Rated Torque (N·m)	242	286
Rated Rotation Speed (R.P.M.)	1500	1500
Rated Current (A)	67.5	93
Rotor Inertia (kg·m <sup>2</sup> ×10 <sup>-4</sup> )	1700	2100
Insulation Level	F Class (155°C)	
Enclosure	IP54	
Cooling method	Fan cooling	

## Servo Motor External Dimension

• 60mm Series

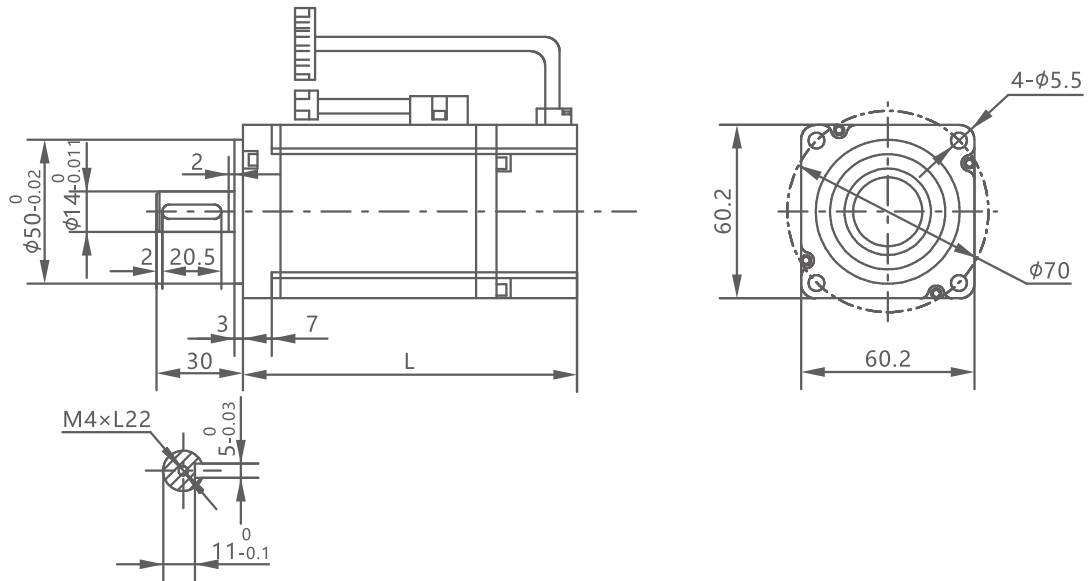

■ 220V

Model	SCH060201C	SCH060401C	SCH060201C-□5	SCH060401C-□5
L (Without Brake)	109	133	75	92
L (With Brake)	157	181	104	121

• 80mm Series

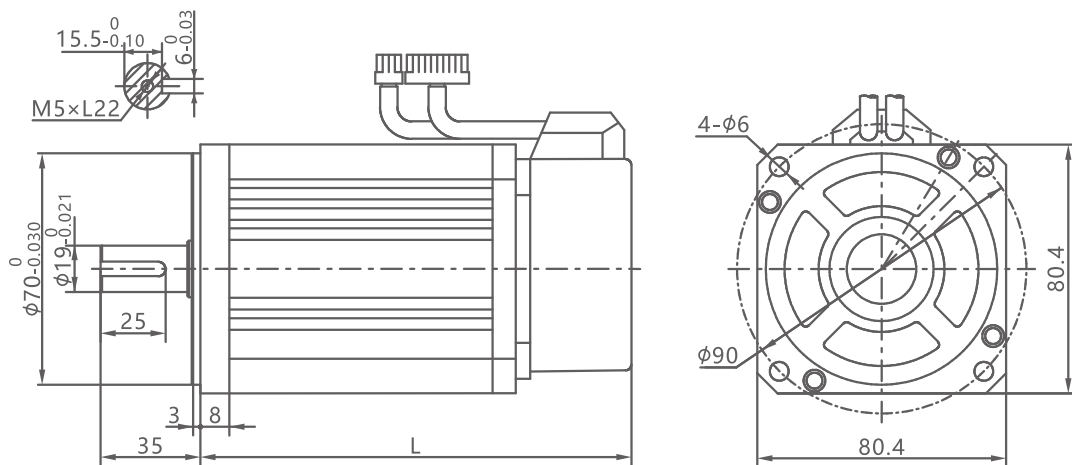

■ 220V/380V

Model	SCH080751C	SCH080751C-□5	SCH080731B	SCH080102E
L (Without Brake)	151	98.5	179	191
L (With Brake)	193	137.5	221	233

• 110mm Series

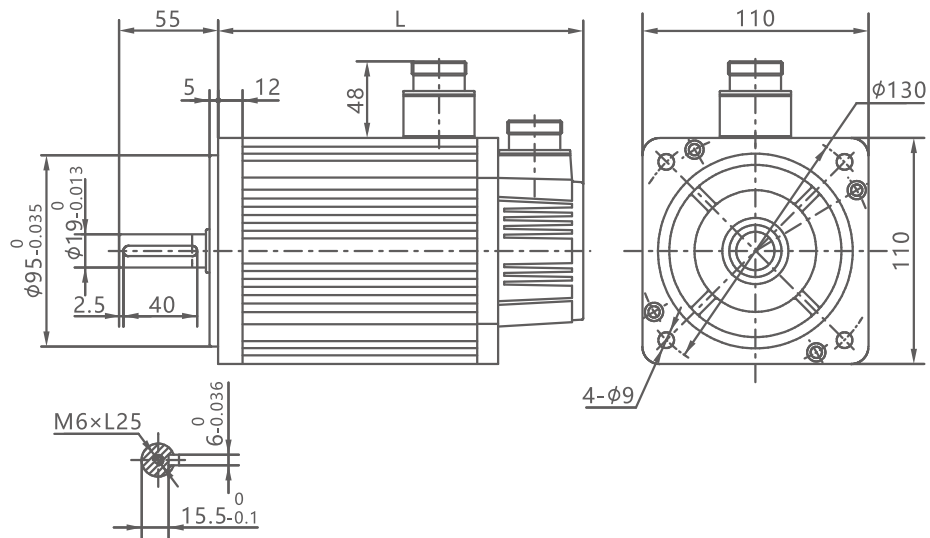

■ 220V/380V

Model	SCH110122C	SCH110152C	SCH110122B	SCH110182C
L (Without Brake)	189	204	219	219
L (With Brake)	254	269	284	284

• 130mm Series

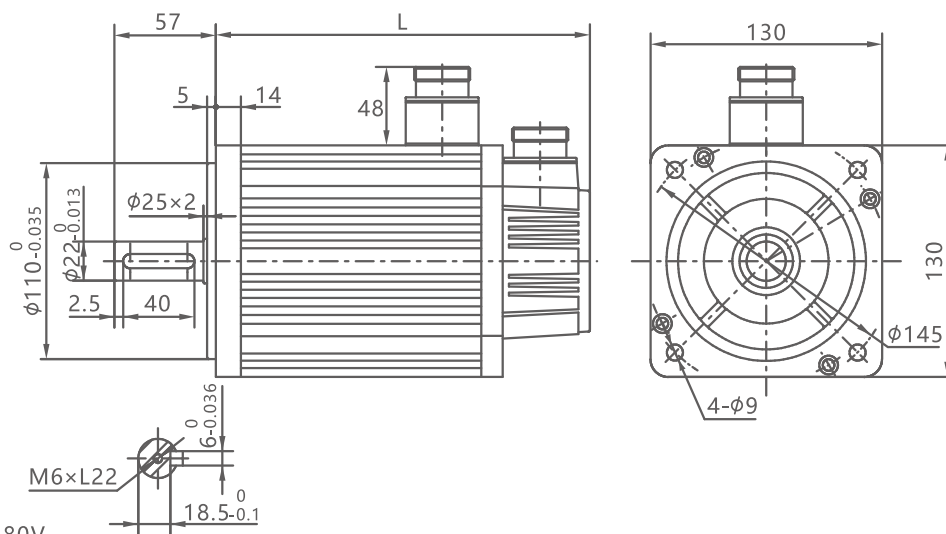

■ 220V/380V

Model	SCH130102E	SCH130132E	SCH130152E	SCH130202E
L (Without Brake)	166	171	179	192
L (With Brake)	226	231	239	252

Model	SCH130102A	SCH130152H	SCH130262E	SCH130232H	SCH130382E
L (Without Brake)	213	213	209	241	231
L (With Brake)	276	276	272	304	294

- 130mm Series
  - H5 series

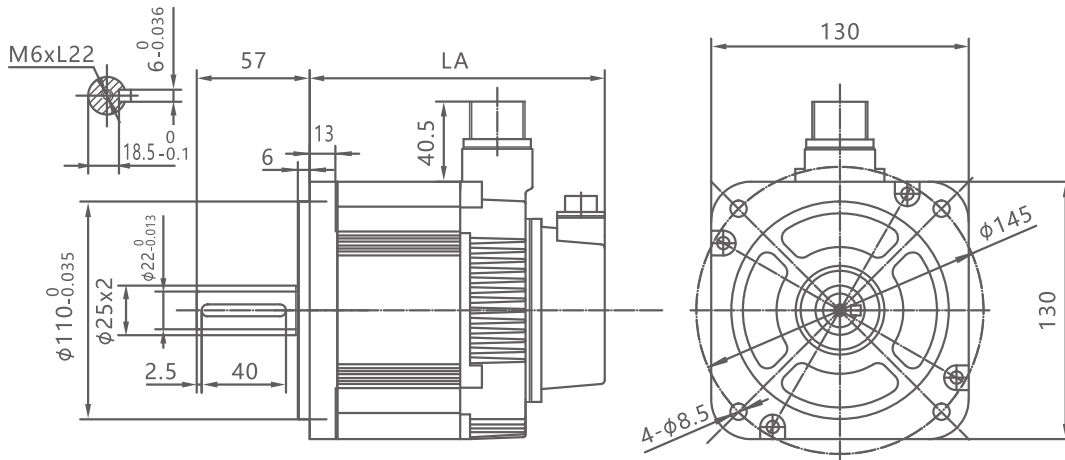

- 220V

Model	SCH130851H-□5	SCH130132H-□5	SCH130182H-□5	SCH130232H-□5
L (Without Brake)	149	169	196	228
L (With Brake)	173.5	199.5	226.5	258.5

- 180mm Series

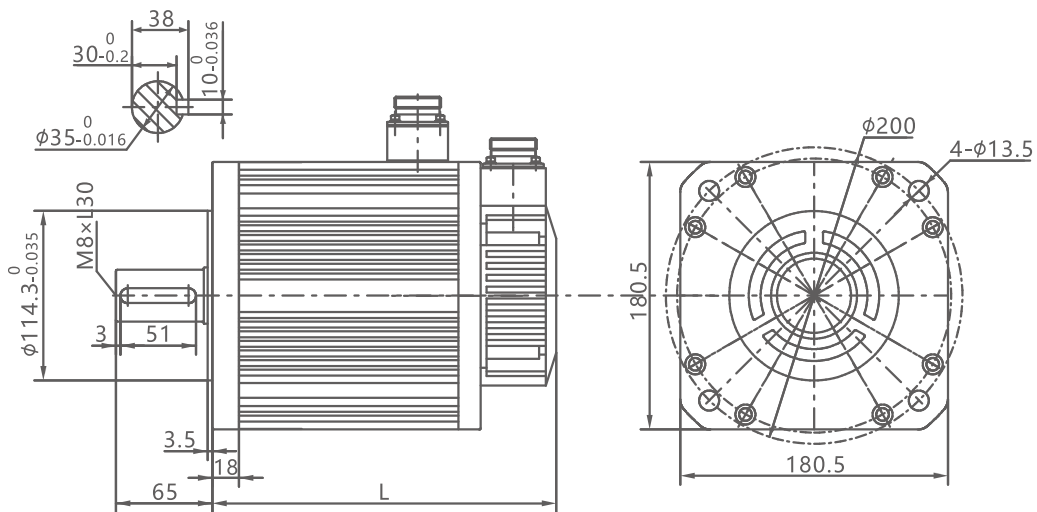

- 220V/380V

Model	SCH180252H	SCH180302H	SCH180432H
L (Without Brake)	226	232	262
L (With Brake)	298	304	334

- 380V

Model	SCH180552H	SCH180752H
L (Without Brake)	292	346
L (With Brake)	364	418

• 200mm Series

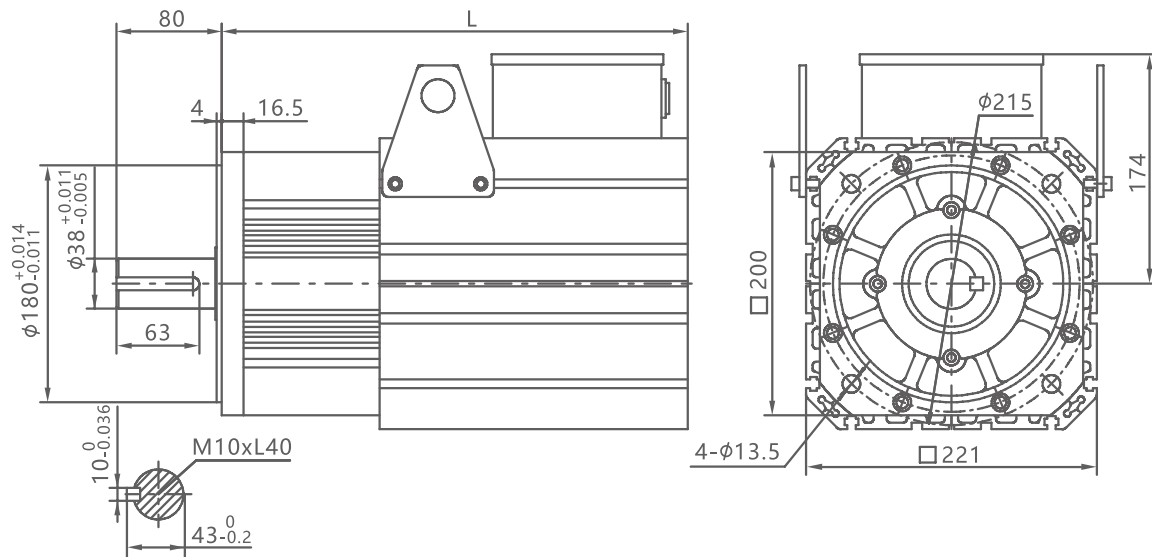

■ 380V

Model	SCH200113B	SCH200113H	SCH200153B	SCH200133H	SCH200183B	SCH200852H
L (Without Brake)	397	440	440	463	463	397

• 230mm Series

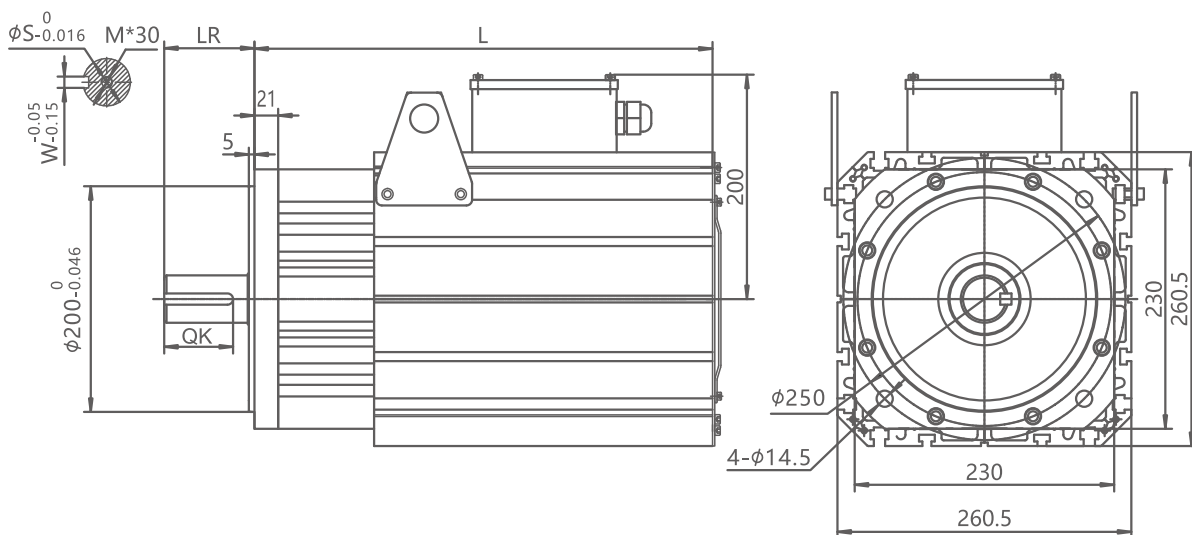

■ 380V

Model	SCH230233H	SCH230303H	SCH230353H
L (Without Brake)	540	558	608

• 260mm Series

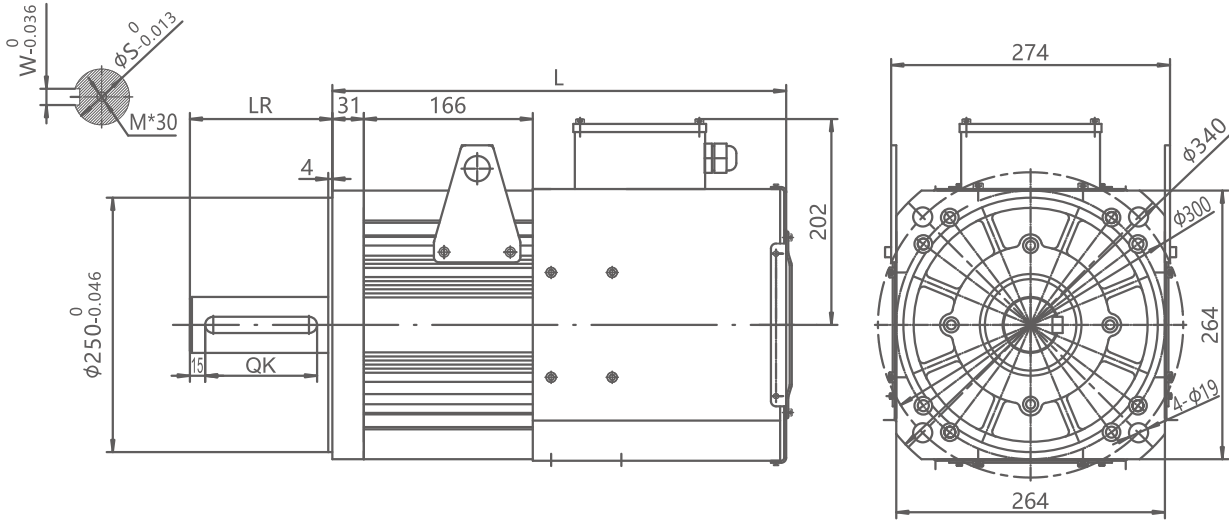

■ 380V

Model	SCH230383H	SCH230453H
L (Without Brake)	556	596

# Options

• Cable (Note: L: Cable length, unit: m)

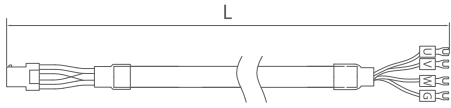
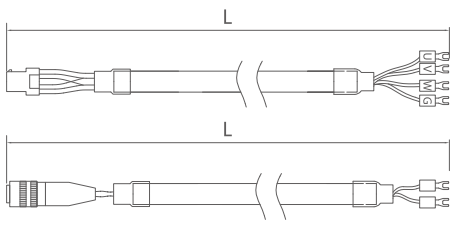
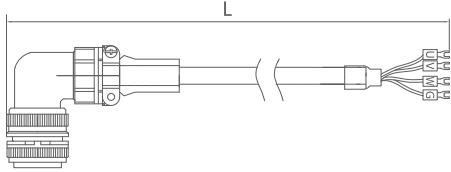
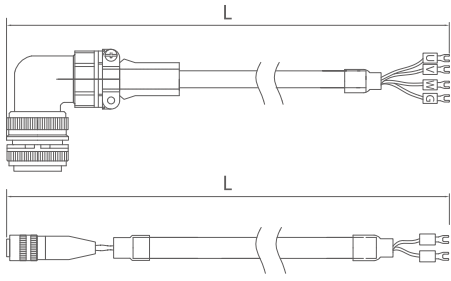
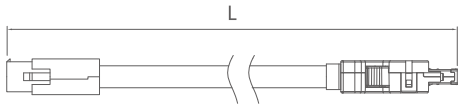
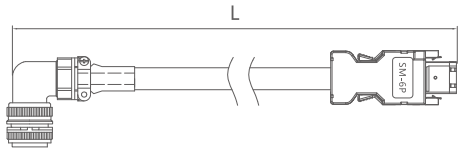
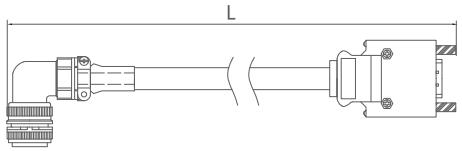
Cable Model	Reference Sample	Matched Motor
DL-SCH086(ZD1Y)-N-L	Without Brake 	
DL-SCH086(ZD1Y)-B-L	With Brake 	SCH060 to SCH090
DL-SCH130(ZD1Y)-N-L DL-SCH180(ZD1Y)-N-L	Without Brake 	
DL-SCH130(ZD1Y)-B-L DL-SCH180(ZD1Y)-B-L	With Brake 	SCH110 to SCH180
SA2FK-P1S(ZD1Y)-L		SCH060 to SCH090
SA2FK-P2S(ZD1Y)-L		SCH110 to SCH260
SA2FK-P2F(ZD1Y)-L		

• Power Cable Type Description

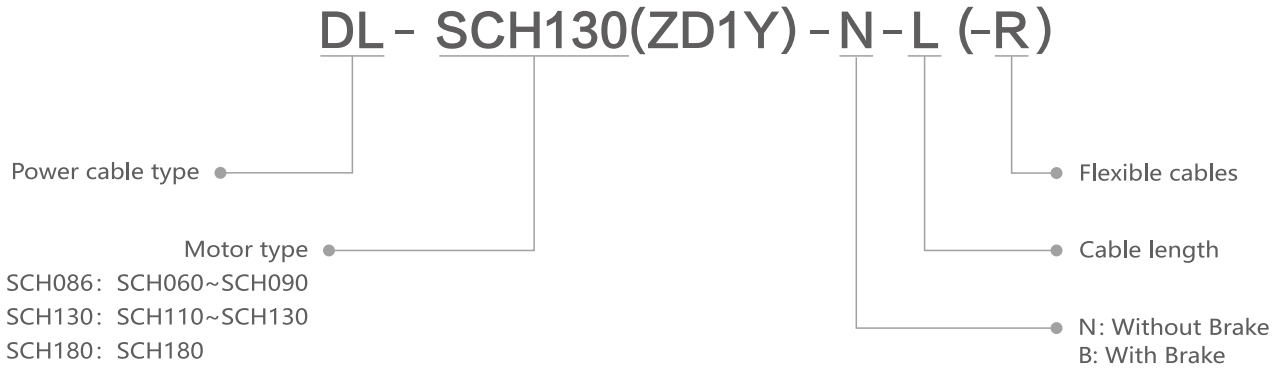

Note: SCH200~SCH260 motor is without power cable from factory, please prepare the cable if need.

• Feedback Cable Type Description

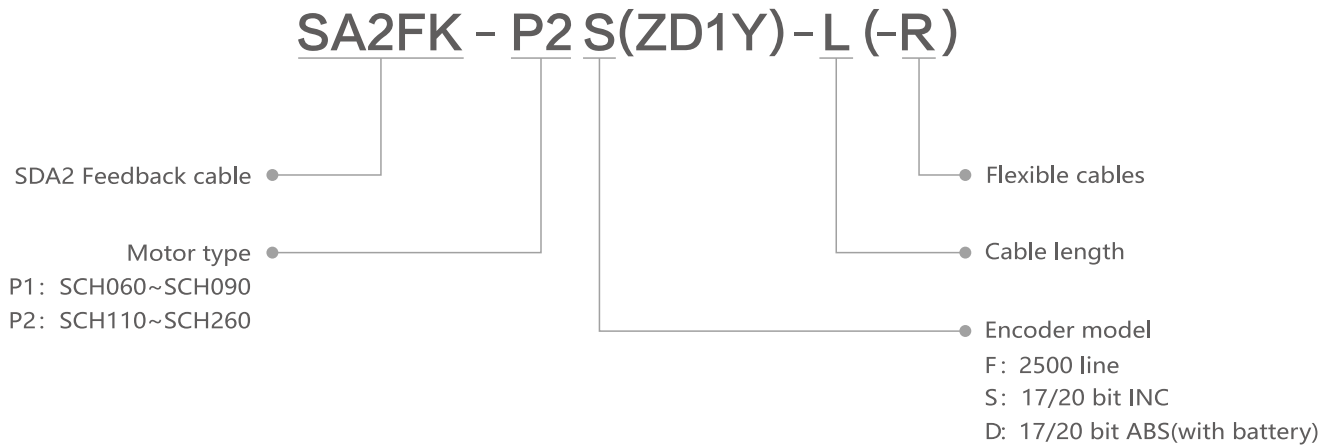

COOPERATIVE CLIENT



☑ **Quanzhou Factory** \_\_\_\_\_  
Address: 3# Zixin Road, Jiangnan Hi-Tech Industrial Park,  
Quanzhou, Fujian, China  
Tel: **+86 595 24678267** Fax: **+86 595 24678203**

☑ **Service Network** \_\_\_\_\_  
Website: **www.savch.net**

☑ **Qualification** \_\_\_\_\_  
Received **ISO9001** and **CE** recognition  
520621280204 V1.4 2026-04-21  
All rights reserved. Subject to change without further notice.

Sales service contact address



SAVCH Wechat  
Service Number