



PG 卡操作手册

Operation Guide of PG Cards

操作手册 (中文)

感谢您使用本公司 PG 卡产品,在产品使用前,请认真阅读本指南。

Operation Guide (ENGLISH)

Thank you for using the PG products. Please read this guide carefully before using the products.

目录

1. 概述.....	1
2. PG 卡安装说明.....	1
3. 电气说明.....	2
3.1 PG01-普通增量式编码器卡.....	2
3.1.1 PG01 接线图.....	2
3.1.2 PG01 端子排布及规格说明.....	3
3.2 PG02-差分式编码器卡.....	4
3.2.1 接线图.....	4
3.2.2 端子排布及规格说明.....	4
3.3 PG03 Resolver Option-旋转变压器.....	5
3.3.1 PG03 旋转变压器扩展卡接线图.....	5
3.3.2 端子排布及规格说明.....	5



CONTENTS

1.Summary.....	7
2.PG card installation instructions.....	7
3.Electrical instructions.....	8
3.1 PG01-Common Encoder.....	8
3.1.1 PG01 Wiring Diagram.....	8
3.1.2 PG01 terminals and specifications.....	9
3.2 PG02 Differential PG card.....	10
3.2.1 Wiring diagram.....	10
3.2.2 Terminal arrangement and specifications.....	10
3.3PG03 Resolver Option.....	11
3.3.1 PG03 Wiring Diagram.....	11
3.3.2 Terminals and specifications.....	错误! 未定义书签。

中文

1. 概述

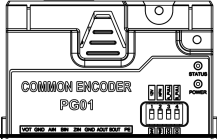
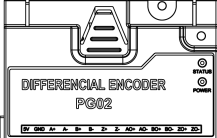
本公司变频器配备了多种编码器扩展卡(即 PG 卡)作为选配件使用,是变频器做速度闭环矢量控制的必选件。请根据不同的编码器输出选择相应的 PG 卡,具体型号和选型如下,请根据选定的编码器选择对应的本公司 PG 卡型号,型号如下:

PG01	电源: 12V/24V; 150mA; 输入: A/B/Z 信号; 电压型/OC/推挽型增量信号,最大 50kHz 分频输出: AO1 BO1(分频可调,范围: 1~255)	 The diagram shows the PG01 Common Encoder card. It features a central component labeled 'COMMON ENCODER PG01' with a digital display showing '0000'. There are several pins and connectors visible on the right side of the card.
PG02	电源: 5V, 200mA; 输入: A+/A-,B+/B-,Z+/Z-差分增量信号,最大 200kHz 分频输出: AO+/AO-;BO+/BO-(分频可调,范围: 1~255)	 The diagram shows the PG02 Differential Encoder card. It features a central component labeled 'DIFFERENTIAL ENCODER PG02'. The layout is similar to PG01 but with different internal components and pin configurations.
PG03	电源: REF+/REF-; 7VRMS, 可选激励频率: 10kHz,20kHz 输入: SIN+/SIN-; COS+/COS-; 分频输出: AO+/AO-; BO+/BO-; ZO+/ZO-	 The diagram shows the PG03 Resolver card. It features a central component labeled 'RESOLVER PG03'. The layout is similar to the other PG cards but with a different internal component.

注意事项:

- 确认待安装的本公司变频器 CU 型号支持扩展卡功能; (下单时可备注或者咨询本公司)
- CU00 不能同时支持外引面板和扩展卡;
- 安装或者拔出扩展卡时,请保证机器是处于下电状态; 严禁热插拔,否则会导致机器或者扩展卡损坏。

2. PG 卡安装说明

安装步骤:

- 检查扩展卡附件包中包含: PG 卡、可插拔端子*1、螺丝*1、说明书;
- 如下图示安装扩展卡:
步骤 1,将扩展卡沿着底部导轨推进 CU 底部,扩展卡的端子与 CU 端子对插到底,两个螺丝孔对齐;
步骤 2,如图示,将螺丝对准螺丝孔,固定 CU 和扩展卡;

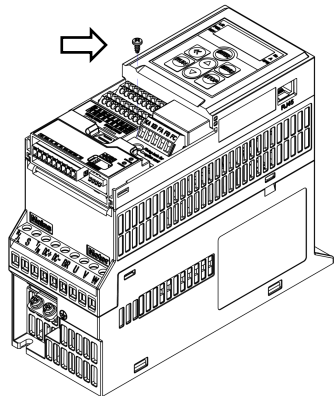
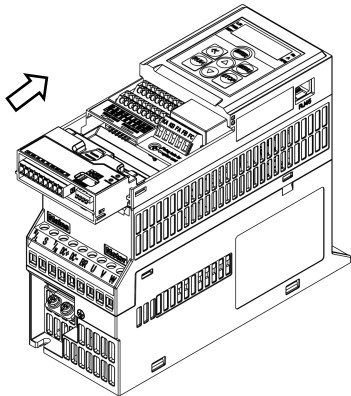

3. 电气说明

3.1 PG01-普通增量式编码器卡

3.1.1 PG01 接线图

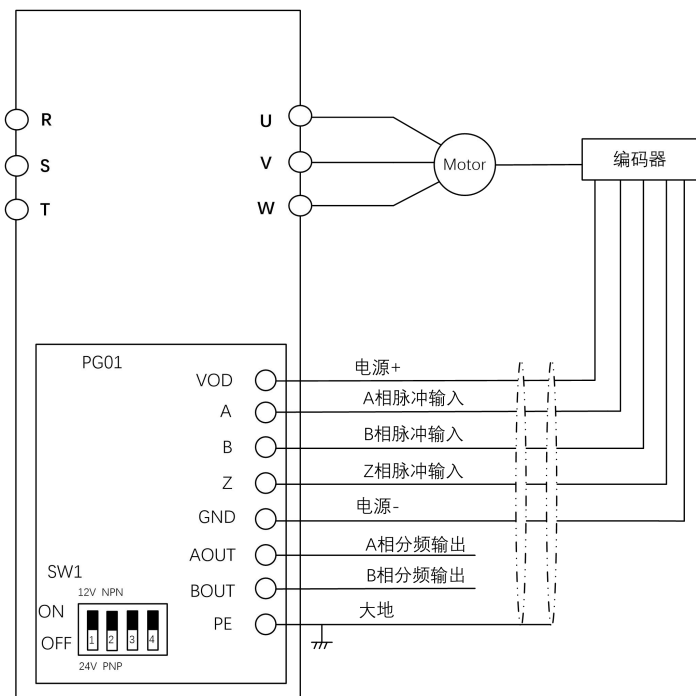

3.1.2 PG01 端子排布及规格说明

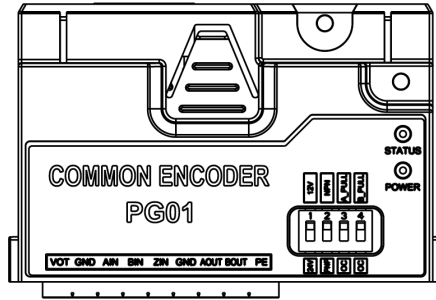

端子名	说明	规格
AIN/BIN/ZIN	脉冲输入信号	最大输入信号频率 50KHz; 可接受的编码器输入型号: 推挽输出型; 电压输出型; 集电极开路输出型;
AO/BO	分频输出信号	通过软件参数设置分频输出系数,分频范围 1-255
VOD	编码器供电电源	通过拨码开关选择 12V 或 24V,默认 24V 电源输出精度: 24V(12V) +/-10%; 最大输出电流 150mA;
GND	内部电源地	
PE	接大地	
拨码开关 SW1	SW-1 电源选择 开关	OFF:24V 默认 ON:12V
	SW-2 编码器模 式选择开关	OFF:(推挽型、电压型) 默认 ON:(推挽型、集电极开路型)
	SW-3 分频输出 A 相上拉选择	OFF:无上拉,集电极开路输出 默认 ON: 上拉到 VOD
	SW-4 分频输出 A 相上拉选择	OFF:无上拉,集电极开路输出 默认 ON: 上拉到 VOD
状态灯	名称	说明
STATUS	故障状态指示灯	红灯常亮: 故障 红灯熄灭: 正常或者未上电
POWER	电源指示灯	绿灯常亮: 电源指示正常 绿灯熄灭: 未上电或电源异常

3.2 PG02-差分式编码器卡

3.2.1 接线图

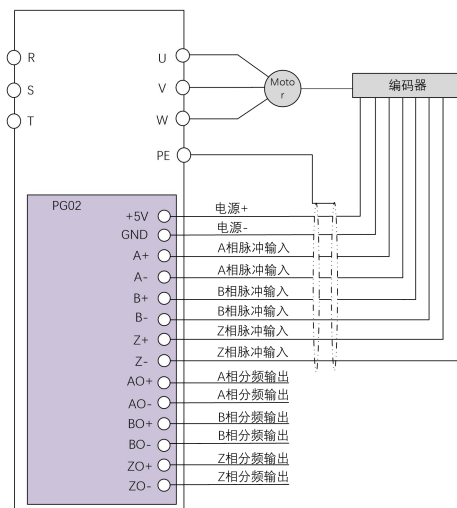

3.2.2 端子排布及规格说明

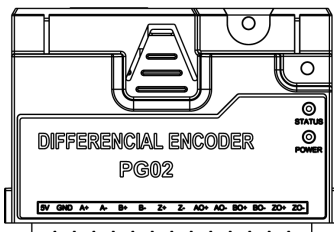

端子名	说明	规格
A+/A-/B+/B-/Z+/Z-	脉冲输入信号	最大输入信号 200KHZ; 可接受的编码器输入型号: 差分增量式编码器输入;
AO+/AO-/BO+/BO-/ZO+/ZO-	分频输出信号	通过软件参数设置分频输出系数,分频范围 1-255
VOD	编码器供电电源	5V 电源输出; +/- 4%; 电源精度: 5V+/- 4%; 最大输出电流 150mA;
GND	内部电源地	
PE	接大地	

状态灯	名称	说明
STATUS	故障状态指示灯	红灯常亮: 故障 红灯熄灭: 正常或者未上电
POWER	电源指示灯	绿灯常亮: 电源指示正常 绿灯熄灭: 未上电或电源异常

3.3 PG03 Resolver Option-旋转变压器

3.3.1 PG03 旋转变压器扩展卡接线图

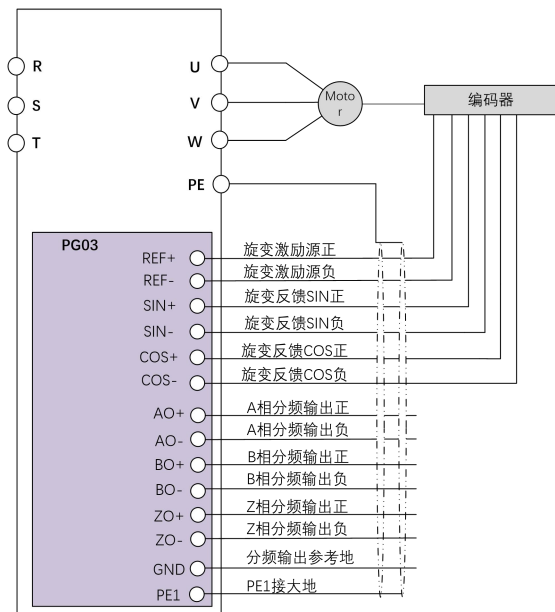

3.3.2 端子排布及规格说明

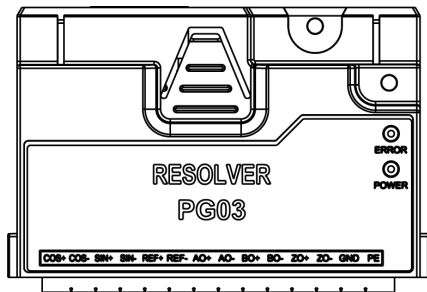

端子名		说明	规格	
REF+/REF-	旋变激励源	VRMS:7V 激励源频率: 10KHZ/20KHZ 分辨率: 12 位		
SIN+/SIN- COS+/COS-	旋变信号输入			
AO+/AO-/BO+/ BO-/ZO+/ZO-	分频输出信号	分频信号: 差分信号输出; 输出信号幅值: 5V; 分频系数: 1		
GND	内部电源地			
PE	接大地			
状态灯		名称	说明	
STATUS	故障状态指示灯	红灯常亮: DP01 扩展卡与控制单元通讯异常 红灯闪烁: DP01 扩展卡内部故障 红灯熄灭: 正常或者未上电		
POWER	电源指示灯	绿灯常亮: 电源指示正常 绿灯熄灭: 未上电或电源异常		
参数号	名称	设定范围	单位	出厂值
P2-70	编码器分辨率	0~4096		1024
P2-71	编码器旋转方向	0: 顺时针; 1: 逆时针		0
P2-74	旋变激励源频率选择	0: 10 1: 10.87 2: 11.63 3: 12.82 4: 13.89 5: 15.63 6: 17.24 7: 20	KHz	0
P5-19	电机速度反馈中断响应功能	0: 无效 3: 点动运行 4: 速度上限运行 5: 故障且跳脱停机 11: 开环运行		5
P5-20	电机速度反馈中断检测阈值	1 ~ 600	RPM	300
P5-21	电机速度反馈中断检测时间	0.00 ~ 60.00	S	0.05
P9-37	编码器输入值			

ENGLISH

1.Summary

The inverter is equipped with a variety of encoder expansion cards (ie PG cards) as optional accessories, which is a must for the inverter to realize speed closed-loop vector control. Please select the corresponding PG card according to different encoder output. The specific models and selection are as follows. Please select the corresponding PG card model according to the selected encoder. The models are as follows:

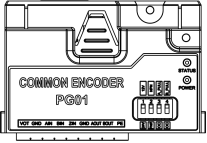
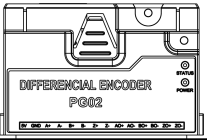
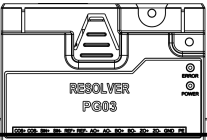
PG01	Power supply: 12V/24V; 150mA; Input: A/B/Z signal; Voltage type / OC / push-pull incremental signal,Max.50kHz Frequency division output: A1 B1(Frequency division adjustable, range: 1~255)	 A rectangular expansion card labeled 'COMMON ENCODER PG01'. It features a terminal block on the left with six pins labeled A, B, Z, and three unlabeled pins. On the right, there are two circular indicators labeled 'OC' and 'PUSH-PULL'. The card is shown being inserted into a slot in a control unit.
PG02	Power supply: 5V, 200mA; Input: A+/A-,B+/B-,Z+/Z- Differential incremental signal,Max.200kHz Frequency division output: A+/A-;B+/B- (Frequency division adjustable, range: 1~255)	 A rectangular expansion card labeled 'DIFFERENTIAL ENCODER PG02'. It features a terminal block on the left with six pins labeled A+, A-, B+, B-, Z+, and Z-. On the right, there are two circular indicators labeled 'OC' and 'PUSH-PULL'. The card is shown being inserted into a slot in a control unit.
PG03	Source: REF+/REF-,7VRMS, 10kHz/20kHz Port: SIN+/SIN-,COS+/COS-; Frequency division output: AO+/AO-,BO+/BO-;ZO+/ZO- (Frequency division adjustable, range: 1)	 A rectangular expansion card labeled 'RESOLVER PG03'. It features a terminal block on the left with six pins labeled AO+, AO-, BO+, BO-, ZO+, and ZO-. On the right, there are two circular indicators labeled 'OC' and 'PUSH-PULL'. The card is shown being inserted into a slot in a control unit.

Notice:

- Confirm that the CU model of the inverter to be installed supports the expansion card function; (you can note when ordering or consult company)
- CU00 cannot support both the external keypad and the expansion card at the same time.;
- When installing or removing an expansion card, please ensure that the machine is powered off; hot swapping is prohibited. Otherwise, the machine or expansion card may be damaged.

2.PG card installation instructions

Installation steps: Check the expansion card accessory package contains: PG card, pluggable terminal *1, screw *1, manual; Install the expansion card as shown below:

- Step 1. Push the expansion card along the bottom rail into the bottom of the CU. The terminals of the expansion card are inserted into the bottom of the CU terminal, and the two screw holes are aligned.
- Step 2, as the picture shows, align the screws with the screw holes to fix the CU and the expansion card;

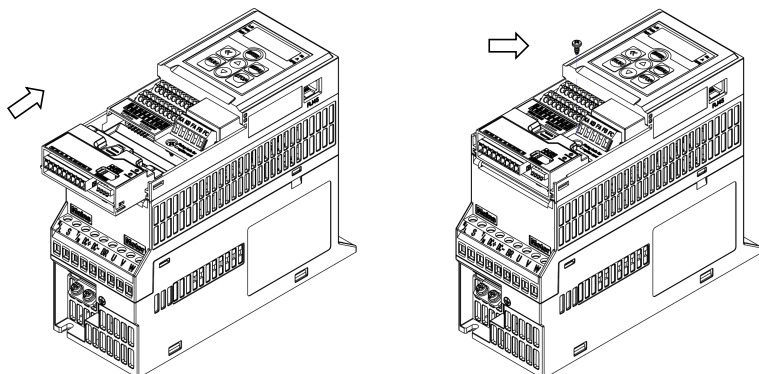

3. Electrical instructions

3.1 PG01-Common Encoder

3.1.1 PG01 Wiring Diagram

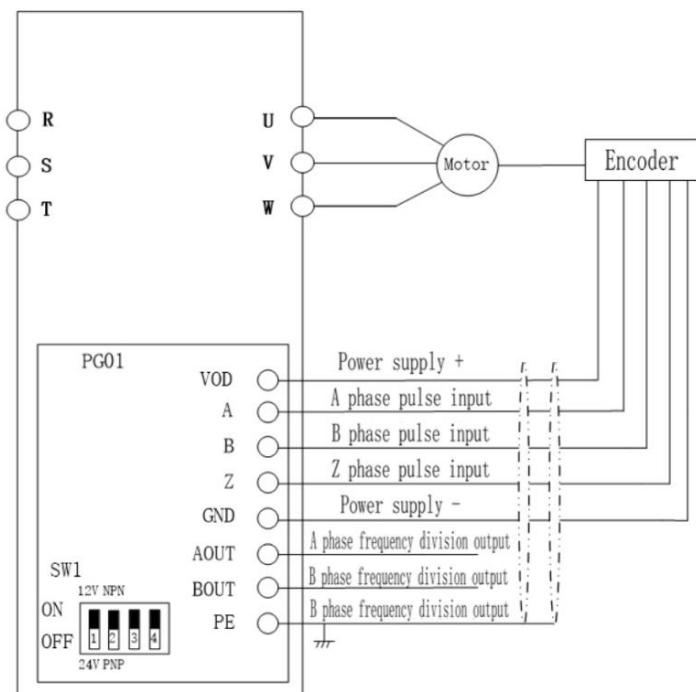

3.1.2 PG01 terminals and specifications

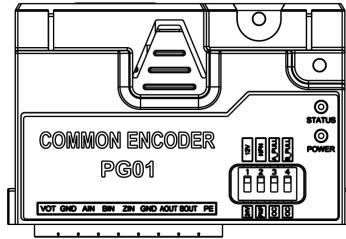

Terminal name	Function	Specification
AIN/BIN/ZIN	Pulse input signal	Maximum input signal 50KHZ; Acceptable encoder input model: Push-pull output type; Voltage output type; Open collector output type;
AO/BO	Frequency division output signal	The frequency division output coefficient is set by software parameters, frequency division range is 1-255.
VOT	Encoder power supply	Select 12V or 24V through the DIP switch, the default is 24V; Power output accuracy: 24V(12V) +/-10%; Maximum output current 150mA;
GND	Internal power ground	
PE	Safety Ground	
DIP switch SW1	SW-1 Power selection switch	OFF:24V default ON:12V
	SW-2 Encoder mode selector switch	OFF:(Push-pull type、Voltage type) default ON:(Push-pull type、Open collector type)
	SW-3 Frequency division output A phase pull-up selection	OFF: No pull-up, open collector output default ON: Pull up to VOD
	SW-4 Frequency division output A phase pull-up selection	OFF: No pull-up, open collector output default ON: Pull up to VOD·
Status light	Description	Status light
STATUS	Fault status indicator	STATUS
POWER	Power Indicator	POWER

3.2 PG02 Differential PG card

3.2.1 Wiring diagram

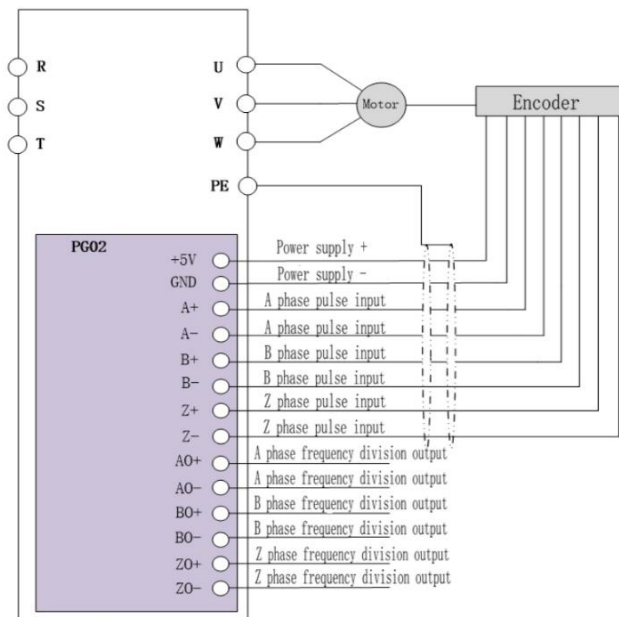

3.2.2 Terminal arrangement and specifications

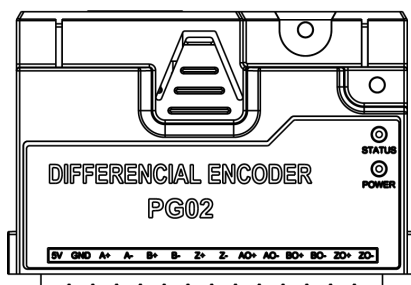

Terminal name	Function	Specification
A+ / A- / B+ / B- / Z+ / Z-	Pulse input signal	Maximum input signal 50KHZ; Acceptable encoder input model: Differential incremental encoder input;
AO+ / AO- / BO+ / BO- / ZO+ / ZO-	Frequency division output signal	The frequency division output coefficient is set by software parameters, frequency division range is 1-255.

Terminal name	Function	Specification
5V	Encoder power supply	5V power output; +/- 4%; Power supply accuracy: 5V+/- 4%; Maximum output current 150mA;
GND	Internal power ground	
PE	Safety Ground	
Status light	Name	Description
STATUS	Fault status indicator	Red light is always on: fault Red light is off: normal or not powered
POWER	Power Indicator	The green light is always on: Power indication is normal The green light is off: the power is off or the power is abnormal.

3.3 PG03 Resolver Option

3.3.1 PG03 Wiring Diagram

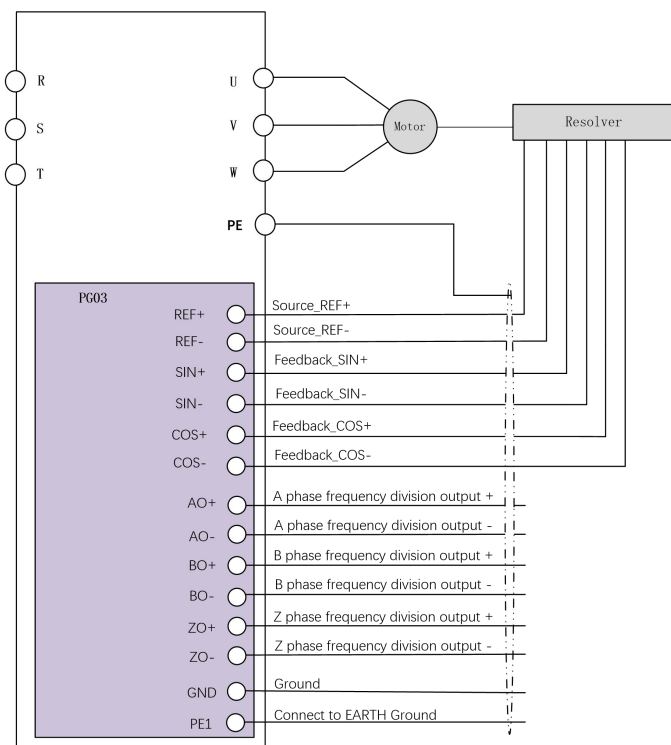

3.3.2 Terminals and specifications

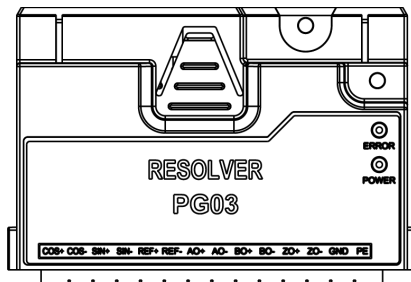

Terminal name	Function	Specification		
A+ /A- /B+ /B- / Z+ /Z-	Pulse input signal	Maximum input signal 50KHZ; Acceptable encoder input model: Differential incremental encoder input;		
AO+ /AO- /BO+ / BO- /ZO+ /ZO-	Frequency division output signal	The frequency division output coefficient is set by software parameters, frequency division range is 1-255.		
5V	Encoder power supply	5V power output; +/- 4%; Power supply accuracy: 5V +/- 4%; Maximum output current 150mA;		
GND	Internal power ground			
PE	Safety Ground			
Status light	Name	Descriptions		
STATUS	Fault status indicator	Red light is always on: fault Red light is off: normal or not powered		
POWER	Power Indicator	The green light is always on: Power indication is normal The green light is off: the power is off or the power is abnormal.		
Parameter number	Name	Setting range	Unit	Factory default
P2-70	Encoder resolution	0~4096		1024
P2-71	Encoder rotation direction	0: Clockwise * 1: Counterclockwise		0
P2-74	Resolver Source frequency	0: 10 * 1: 10.87 2: 11.63 3: 12.82	KHz	0

Parameter number	Name	Setting range	Unit	Factory default
P2-74	Resolver Source frequency	4: 13.89 5: 15.63 6: 17.24 7: 20	KHz	0
P5-19	Motor speed feedback interrupt response function	0: invalid 3: Jog running 4: Speed limit running 5: Malfunction and tripping stop 11: Open loop running		5
P5-20	Motor speed feedback interrupt detection threshold	1 ~ 600	RPM	300
P5-21	Motor speed feedback interrupt detection time	0.00 ~ 60.00	S	0.05
P9-37	Encoder feedback			

■ Innovate for more | win forever

■ Industry intelligence | Energy saving | Green power

Quanzhou Factory

Address: 3# Zixin Road, Jiangnan Hi-Tech Industrial Park, Quanzhou, Fujian, China

Tel: 0595-24678267

Fax: 0595-24678203

Service Network

Website: www.savch.net

Qualification

Received ISO9001 and CE recognition

All rights reserved. Subject to change without further notice.

Version : V1.0 2024-11-22