

Basic Wiring Diagram

Wiring of AC motor drive can be divided into two parts, the main circuit and control circuit. After removing the cover, terminals of main circuit and control circuit shall be found. Users must connect terminals as diagram shows.

The following diagram is the standard wiring diagram. If only digital control panel was used, only main circuit terminal wiring applicable.

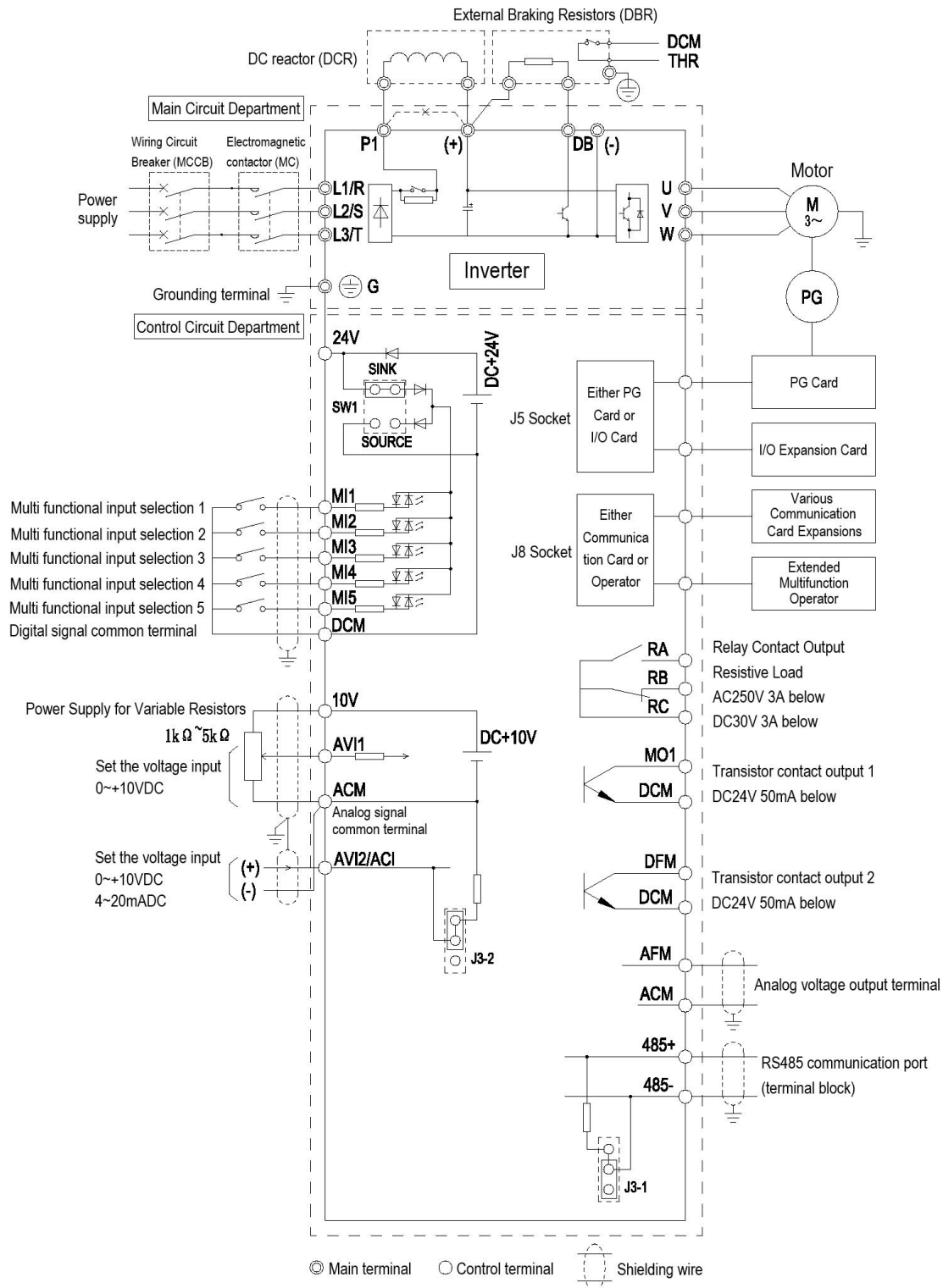

Remarks:

1. The external terminal has two AVI inputs (AVI1, AVI2), one of which is shared with ACI and can be switched to each other.
2. Analog current frequency command ACI: It can switch 4~20mA or 0~+10V as input signal according to J3.
3. There are 5 multi-function input terminals (MI1~MI5) in the external terminal, and the configuration input can be selected.
4. The external terminals have 2 open collector outputs (MO1, DFM).
5. The external terminal has one relay output (RA-RB-RC).
6. It can be equipped with I/O expansion card, the whole machine realizes 2 analog (voltage/current optional) signals and 2 relay outputs.
7. The DC reactor, braking unit and braking resistor are selected according to the requirements. When using the DC reactor, please remove the short-circuit copper sheet between P1 / (+) before connecting.