

S3100L series inverter

Elevator Specialized

User manual



S3100L series inverter

Elevator Specialized

User manual

File No. 520100000001

Vision No. V1.1

Filing time 2026-01-26

SAVCH electric provide a full range of technical support for our customers.

All users could contact with the nearest SAVCH office or service center,
also could contact with our headquarters directly.

SAVCH Electric reserves the copyrights and all rights,

Subject to change without further notice.

CONTENT



PREFACE	1
1. SAFETY INSTRUCTIONS	2
1.1 Notes for Operation	2
1.2 Notes for Operation Environment	4
2 HARDWARE DESCRIPTION AND INSTALLATION	5
2.1 Operational Environment	5
2.2 Model Description	6
2.3 Inverter Specifications	7
2.4 Basic Wiring Diagram	13
2.5 External Dimensions	15
3 KEYPAD DESCRIPTION	17
3.1 Keyboard Description for Digital Operator	17
3.2 Description of Keyboard Operation	19
3.3 Preliminary Operation-not Connecting with Motor	23
4 FUNCTIONAL PARAMETERS LIST	25
5 DESCRIPTION OF FUNCTIONAL PARAMETERS	46
00 Basic Functions Parameters	46
01 Motor Control Parameters	53
02 Vector Control Parameters	55
03 V/f Control Parameters	59
04 Input Terminal Parameters	61
05 Multi-Speed	68
06 Output Terminal Parameters	71
07 Start and Stop Control Parameters	73
08 Man-machine Interface Parameters	76
09 Accessibility Parameters	79
11 Fault and Protection Parameters	87
12 Serial Communication Parameters	92
17 Torque Control Parameters	98
22 Control Optimization Parameters	99
24 Auxiliary function parameters 1	100
26 Specific parameters	100
99 Monitoring Parameters	103
6 TROUBLE SHOOTING	104
6.1 Failures & Failure Elimination	104
6.2 General troubleshooting method	107
7 MAINTENANCE AND AMBIENT ELEMENTS	108
7.1 Braking Resistor Selection Guide	109
7.2 Breaker, cable and contactor specifications list	110
7.3 Input/output AC reactor and DC reactor specifications	110
7.4 Input/output filter specifications	110

Thank you for choosing SAVCH inverter! This instruction manual, which includes operation descriptions and notes for maintenance, shall be delivered to the end-user.

For safety running and effective operation, this instruction manual shall be read thoroughly prior to use, which shall also be preserved for later use. Provided problems occur and solution is not provided in this instruction manual, contact your SAVCHELECTRIC representative or contact with our company directly. Our professional technicians will serve for you actively. And please continue to adopt products of SAVCH, give valuable opinion and advice.

1. Reading Instructions

Symbols of " DANGER" and" CAUTION" in the manual indicates that, for safety running or maintenance of inverters or other electrical products, attention shall be attached during delivering, installation, operation and checks for the inverter. And these notes shall be applied for a better and safer operation.

 DANGER	Indicates a potentially hazardous situation visiting. If not used correctly, personnel damage even death may be caused.
 CAUTION	Indicates a potentially hazardous situation visiting. If not used correctly, serious damage to inverter or machine may be resulted.

DANGER

- Never connect wires while power on. Do not check components or signal for circuit board during operation.
- Do not dismantle or change inner wire, circuit or components unnecessarily.
- Make sure grounding terminals are correctly grounded. 220V level: Grounding III, 440V special grounding.

CAUTION

- Do not perform a withstand voltage test for components of inverter, it can cause semi-conductor components to be damaged by high voltage.
- Never connect the output terminals U, V, W to AC power supply.
- IC of CMOS on control circuit of the inverter shall be damaged by electrostatic influence. Do not touch main circuit board.

2. Products Receiving

All products have been performed with strict test and inspection. After receiving the inverters, the following checks shall be performed.

- To check that SAVCH inverter, an instruction manual and a cover is inside of the package
- To check whether model number correspond with model and capacity your purchase order.
- To check whether there are damaged parts during transportation and delivering. If there are, do not connect with power supply.

If any of the above checkpoints are not satisfactory, contact your SAVCHELECTRIC representative for a quick resolution.

1. SAFETY INSTRUCTIONS

1.1 Notes for Operation

Before wiring

 **CAUTION**

Specification of applying power supply shall correspond to input voltage of the inverter.

 **DANGER**

Main circuit terminals must be correct, R/L1, S/L2 and T/L3 is input terminals and it's forbidden to use mixing with U/T1, V/T2 and W/T3. Failure to observe this may cause the inverter damaged.

Installation

 **DANGER**

- When handling the inverter, do not draw front cover directly but handle it by the heat sink to prevent the cover from falling off and to avoid the falling of the inverter and causing personal injury or damage to the inverter.
- Install the inverter on a base made of metal or other non-flammable material, Do not place flammable object nearby to prevent fires.
- If several inverters are installed in a electric cabinet, add extra cooling fan to keep the temperature lower than 40 °C to prevent over-heating or fire.
- Operator shall be dismantled or refitted after power supply is off. Fixed operator shall be processed as diagram shows.
- Confirm whether the input voltage is identical with the voltage in the nameplate on the right side of the inverter, Otherwise the malfunction could happen.

Operation

 **DANGER**

- Never put in or take off the motor during operation, otherwise over-current even over burning the main circuit of the inverter may happen.
- Do not remove the cover while current is flowing. Failure to observe this may result in electrical shock to personnel.
- When auto-restart function is set, do not approach the machine since motor can be reset suddenly after being stopped.
- As STOP key can be invalid unless being set, which is different from the emergency stop key, please pay attention to it.

⚠ CAUTION

- Never touch heat sink or discharging resistor since temperature may be very high.
- Since it is easy to change running speed from low to a high speed, verify safe working range of motor and machine before running.
- Pay attention to relative equipments before using the brake unit.
- Do not check signals during running.
- All parameters of the inverter have been preset at the factory according to line frequency. Do not change the settings value at will.
- Please confirm that the power is turned off and wait for 10 minutes before disassembly or inspection.

Check and maintenance

⚠ CAUTION

- Ambient temperature for operating the inverter shall be -10°C to $+40^{\circ}\text{C}$ and 90%RH no condensation.
- After removing the cover, ambient temperature for operating the inverter shall be -10°C to $+50^{\circ}\text{C}$ and 95%RH no condensation, the ambient environment must be without drips of water or metal dust. If it was, the cover shall be set and check ambient temperature is within -10°C to $+40^{\circ}\text{C}$.

Disposal precaution

⚠ CAUTION

- Explosion may occur when burning the electrolytic capacitor of the main circuit and printing plate. Toxic gas may be generated when burning control panel and other plastic fittings.
It shall be treated as Industrial waste when disposing of it.

1.2 Notes for Operation Environment

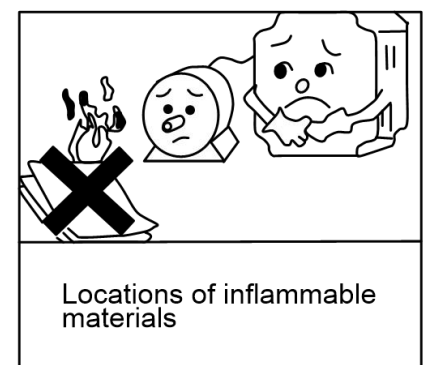
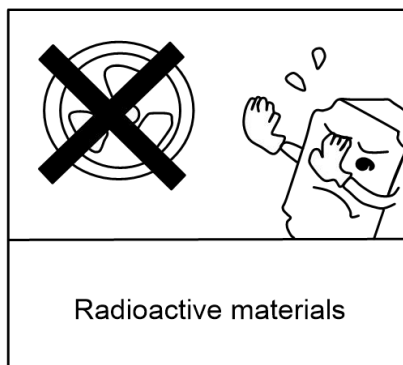
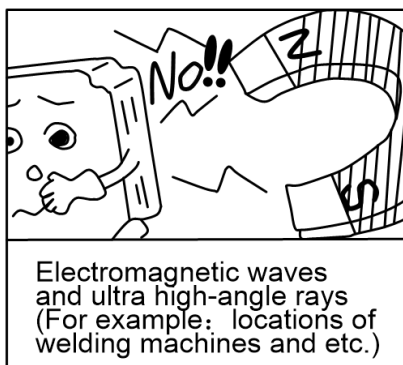
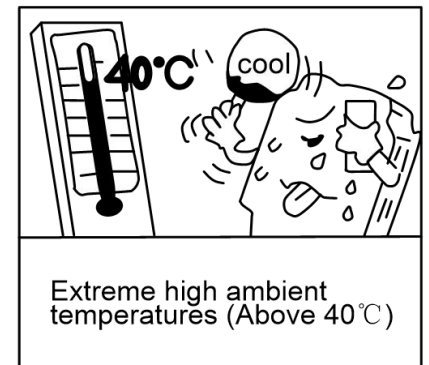
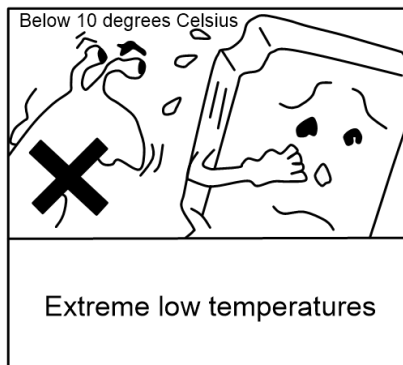
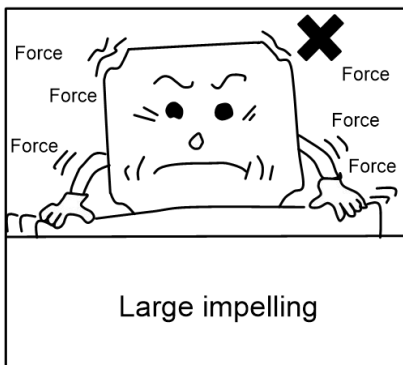
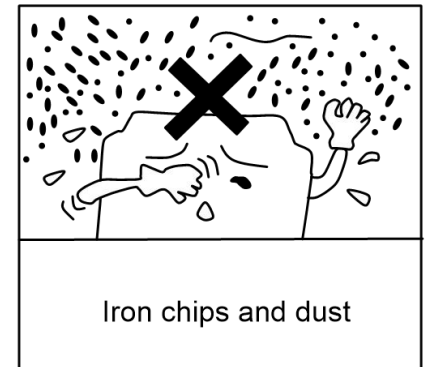
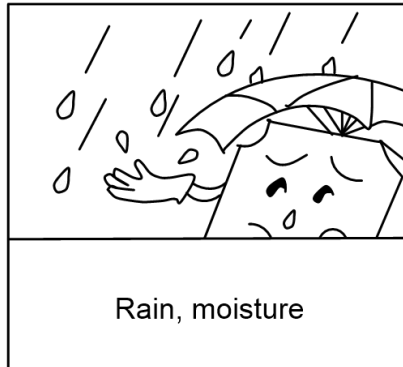
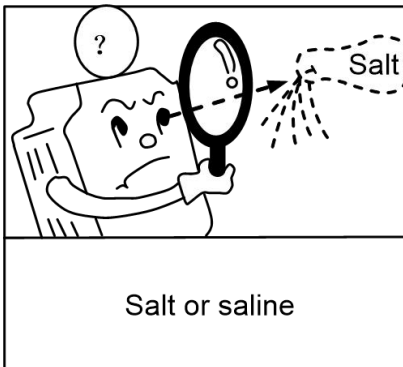
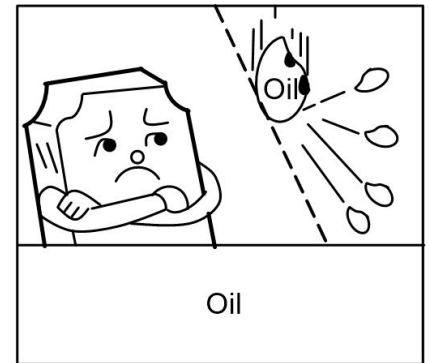
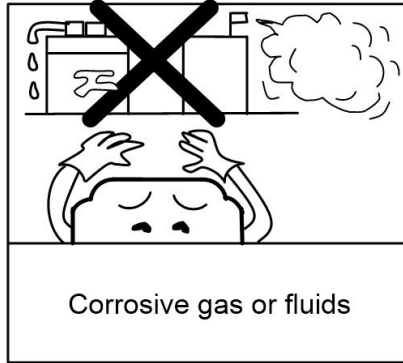
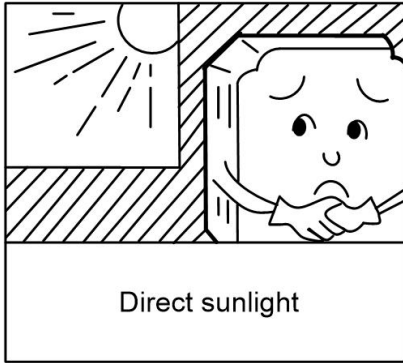

2 HARDWARE DESCRIPTION AND INSTALLATION

2.1 Operational Environment

Since operation environment can directly influence functions and operation life, to ensure proper performance and long operation, follow the recommendations below when choosing allocation for installing the inverter:

- Use only with the ambient temperature range: -10°C to $+40^{\circ}\text{C}$; -10°C to $+50^{\circ}\text{C}$ applicable when dust cover is removed.
- Rain, moisture
- Direct sunlight. (Avoid using outdoors)
- Corrosion of oil sprays or salt
- Corrosive fluid and methane
- Dust or batting and metallic particles in the air
- Radioactive materials and inflammable materials
- Electromagnetic interference (Avoid using together with welding machine or dynamic machines.)
- Vibration. (If inverter must be used in this environment, an anti vibration pad is necessary).

Attention shall be attached to clearance of inverters allocated closely. A fan shall be installed to make sure temperature is lower than 40°C

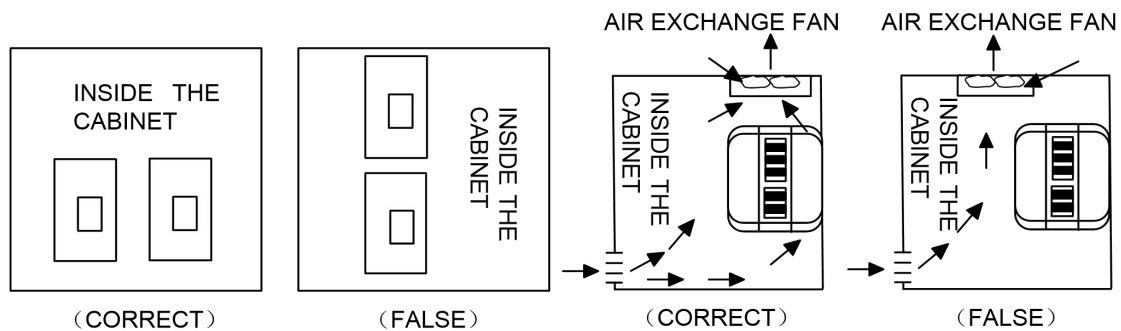

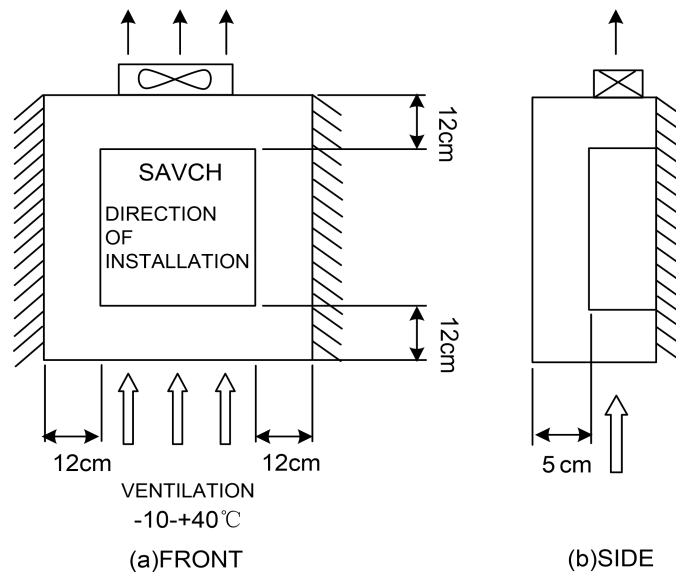

For cooling off, face shall be toward front and upper parts shall be upwards.

Clearance shall meet the following specifications:



2.2 Model Description

Model	→	TYPE: S3100L-4T7.5G	CE
Input power supply Spec	→	SOURCE: AC 3PH 380~460V 50/60Hz	
Output power supply Spec	→	OUTPUT: 3PH 0~460V 13kVA 17/21.7A	
Output frequency	→	FREQUENCY RANGE: 0~500Hz	
		S/N: 	
		NJ3019380000037	
Designed by Savch Electric			
SAVCH ELECTRIC CO.,LTD.			

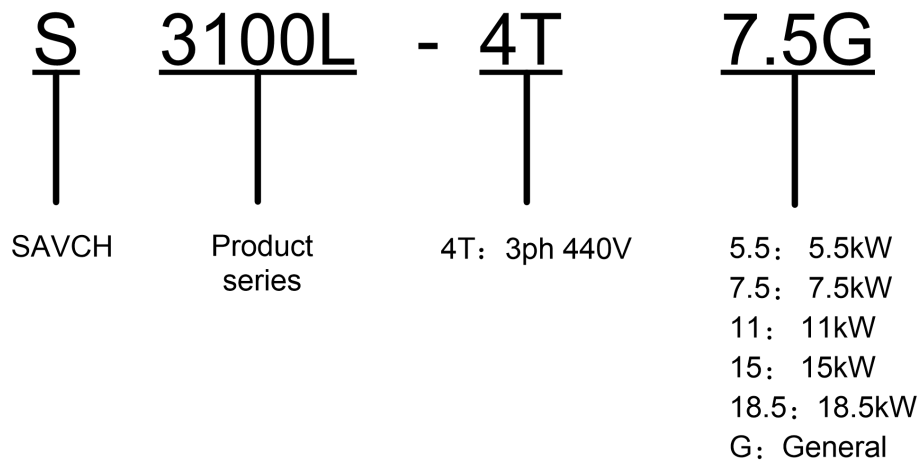



2.3 Inverter Specifications

2.3.1 Standard Specifications

Three phase 440V Series

Item		Specification				
S3100L-4T□□□G		5.5	7.5	11	15	18.5
Output	Maximum applicable motor output power(kW)	5.5	7.5	11	15	18.5
	Maximum applicable motor output power(HP)	7.4	10	14.7	20	24.7
	Output rated capacity(kVA)	9.9	13	19.1	24.4	28.2
	Output rated current(A)	13	17	25	32	37
	Output frequency range	0~500Hz				
	Overload capacity	150%-60seconds				
	Max output voltage	Same to input voltage				
Input	Phase,voltage,Frequency	Three phase·380-460V ·50/60Hz				
	Voltage frequency variations	Voltage:±15% Frequency:±5%				
	Input current(A)	15	20.5	26	35	38
Cooling method		Fan cooling				

2.3.2 General Specification

Item		Detailed information	
Control characteristic	Control mode	V/f control, vector control(SVC/FVC), torque control	
	range of output frequency	0~500.00Hz	
	Frequency setting resolution	0.01 Hz	
	Output Frequency setting resolution	0.01 Hz	
	PWM carrier frequency	Adjust from 0.5khz to 12khz	
	Torque boost	Vector control(SVC/FVC):0.5Hz/150%	
	Jump frequency	Adjust from 0.1hz to 500.00hz	
	Acceleration/deceleration time	0.00 to 65000 seconds (4-stage acceleration/deceleration time is set independently), linear or S-curve acceleration/deceleration mode. The start-stop ratio of 4 groups S-curve can be set independently.	
	Over current stall prevention level	Can be set according to the motor load characteristics with 100~200% of the rated current of the driver	
	DC brake	When stopping, it can be operated from 0.00 to the maximum operating frequency, and the braking current is 0 to 100% of the rated current; Start time 0-100.0 seconds, stop time 0-100.0 seconds.	
	Brake torque	20% (external optional brake resistor can reach 125%) (1-30HP brake transistor built-in, 40HP and above can be connected to the external brake unit module)	
	Speed ratio	Vector control:1:100	
operation characteristic	Frequency setting signal	bit operation board	Set by  
		external terminal	0-10VDC, 4-20mADC, Serial communication(RS485),Multi-speed
	Operation signal	bit operation board	Available to be operated by RUN,STOP,JOG keys
		external terminal	2-wire / 3-wire operation, jog operation, serial communication (RS485)
	Input terminal of multi-function	Forward and reverse running, three-wire operation control, Forward and reverse jog running, free stop, reset fault, running pause, external fault input, increment/decrement frequency terminal setting, 16-segment preset speed switching, acceleration/deceleration time switching , frequency source switching, running command switching, prohibit acceleration and deceleration, disable torque control, frequency increase and decrease setting clear, stop DC braking, frequency modification enable, speed control and torque control switching, clear running time of this time,En enabling signal, emergency power.	
	Output terminal of multi-function	Inverter operation, fault output, frequency level detection FDT output, frequency arrival, zero speed operation, overload pre-alarm, cumulative running time arrival, frequency limitation, torque limit Ready to run, AVI1>AVI2, upper limit frequency arrival, lower limit frequency arrival (operation related), undervoltage status output, communication setting, cumulative power-on time arrival, frequency arrival output, timing arrival output, offload, reverse In operation, the zero current state, the module temperature reaches, the output current exceeds the limit, the lower limit	

Item		Detailed information
		frequency arrives (the stop is also output), the alarm output (continues to run), and the running time arrives, Running contactor output and brake output.
	Analog signal output	Corresponding to the actual output frequency, output current, output voltage, etc.
	Fault signal contact	Contact "ON" (one "C" contact relay or two open collector outputs when the AC drive fails)
Inner function		Output frequency upper and lower limit setting, instantaneous power failure restart, abnormal fault restart, speed tracking, multi-speed operation, timing control, Automatic regulated output regulation, Abnormal record, parameter lock, parameter factory reset, Reverse rotation prohibited, overcurrent stall prevention, overvoltage stall prevention, electronic thermal relay, No weight start-up compensation, emergency power function.
Protection function		Short circuit protection, acceleration over current, deceleration over current, constant speed over current, acceleration over voltage, deceleration over voltage, constant speed over voltage, bus undervoltage fault, motor overload, inverter overload, over torque protection, loss phase on the input, loss phase on the output, module overheating, external fault, communication fault, current detection fault, motor self-learning fault, parameter read and write abnormality, inverter hardware abnormality, motor short circuit to ground, running time arrival, the power-on time arrives, the load dropped, and the fast current limit timeout.
Number of part on keypad		Contains 8 function keys, 5-digit 8-segment LED display, 7 status indicator LED lights Can set the frequency, display the actual output frequency, output current, user-defined unit Parameter browsing and modification settings and parameter locking, abnormal fault display Executable operation, stop, reset, forward/reverse, jogging
environment	Operation temperature	-10°C to +50°C (+40°C ~ +50°C Below 90%RH, No condensation)
	Temperature of stock	-20°C to +60°C
	Humidity of operation environment	Below 90%RH, No condensation
	Height of installation	No more than 1000m in height, no corrosive gas, liquid, dust
	Vibration	Below 20Hz 9.80665m/s ² (1g), 20~50Hz 5.88m/s ² (0.6g)
	Enclosure	IP20 (Depending on the end customer's installation environment)

Note: The instantaneous power failure compensation time varies due to the inverter capacity. If a long instantaneous power failure time is required, the external "instantaneous power failure compensation device" can be added.

Inverter Using and the Main Circuit Wiring, the Basic Wiring Diagram

Peripheral Equipment Application and Precautions

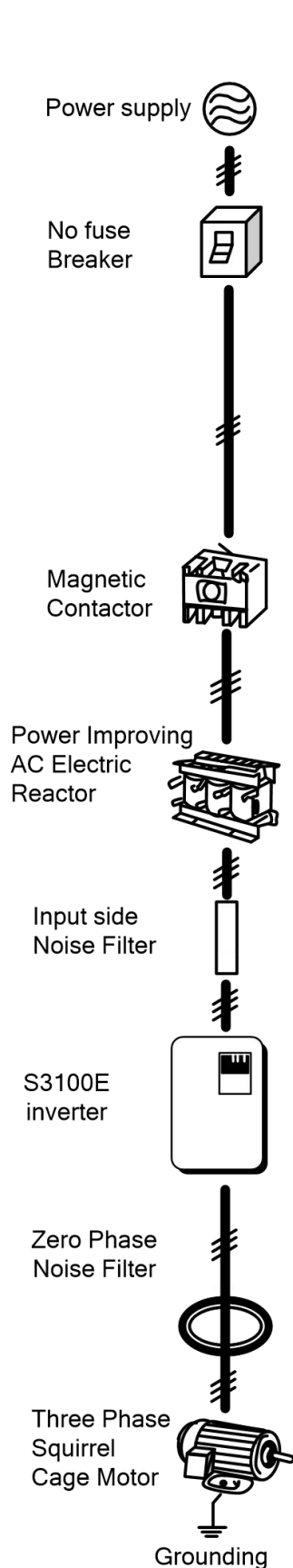

Power:

- Use the power supply in the permissible specifications of the inverter model to avoid damaging the drive.

No fuse circuit breaker(MCCB):

- A non-fuse circuit breaker (MCCB) must be installed between the AC power supply and the inverter, but do not use it as inverter's operation / stop switching function.
- Use a non-fuse circuit breaker (MCCB) that complies with the rated voltage and current rating of the inverter. When the capacity is selected, it is at least 2 times the sum of the rated output current of the inverter (mainly considering 150% of the inverter overload, 1min).

Leakage circuit breaker(RCD/ELCB):

- Please install the leakage circuit breaker, to prevent leakage caused by the malfunction and to protect the safety of the use of personnel;
- Each inverter should use a dedicated circuit breaker whose sensitive current is more than 30mA;
- When using an ordinary circuit breaker, the current sensitivity must be more than 200mA, operation Time must be more than 0.1s.

Electromagnetic contactor:

- Normally, there is no need to add electromagnetic contactor, but it can be used as an external control protection, automatic restart after power failure and other functions, must install electromagnetic contactor.
- When using the brake unit, please connect to the thermal relay contact of the brake unit, close the electromagnetic contactor when overheating;
- Do not use the electromagnetic contactor as the inverter's operation / stop switching function, which will shorten the life of the inverter.

Power Improvement AC Reactor:

- If a large capacity (500KVA or more) is used for the inverter, an excessive peak current may flow into the input side of the inverter, and the rectifier element may be damaged. In this case, the AC reactor can also improve the power factor on the power supply side.

Input side noise filter:

- It is possible to remove the noise from the power supply line into the inverter and to reduce the noise from the inverter to the power supply line.
- When there is an inductive load around the inverter, please ensure to install it.

Inverter:

- Input power terminals R / L1, S / L2, T / L3 are connected without any phase sequence.
- The output terminals U / T1, V / T2, W / T3 are connected to the U / T1, V / T2, W / T3 terminals of the motor. If the inverter is running forward, the motor is reversed. / T2, W / T3 terminal in any two can be adjusted.
- Do not connect output terminals U, V, W to AC power to avoid damage to the inverter.
- Ground terminal should be properly grounded, 220V level: grounding resistance should be below 100 Ω , 440V class: grounding resistance should be 10 Ω or less.

Zero phase filter:

- When you want to reduce the electromagnetic interference caused by the inverter, it is effective in the range of 1MHz ~ 10MHz. The more the number of the motor wires are bypassed, the better. Install as close to the inverter as possible, suitable for either the input side or output side of the inverter.

Wiring shall be checked whether correct or not. Peripheral wiring shall fulfill the following requirements.

(Warning: Do not use a buzzer of control circuit to check wiring)

(A)Wiring for control circuit Power supply must be isolated or far from other high voltage wirings or high current power lines, thus electromagnetic interference can be avoided. See diagrams below:

- Individual power supply bridge for inverter

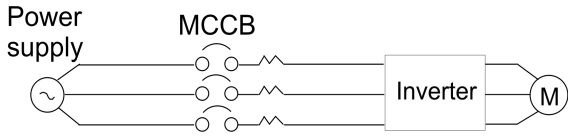

- Good effect may not be received if general use noise filters are applied



- If inverter power supply circuit is used commonly with other machines, inverter-specialized noise filter or isolating transformer shall be added.

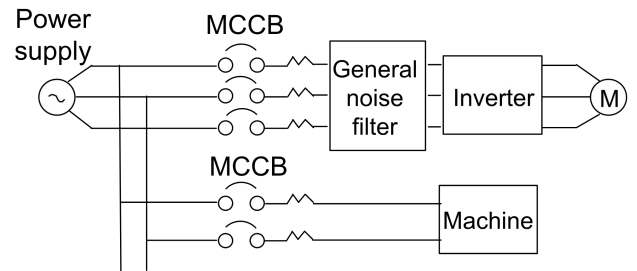
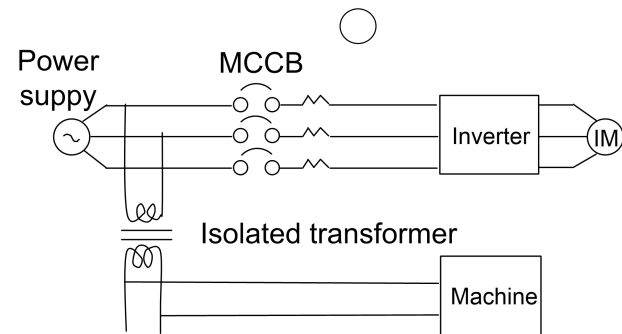
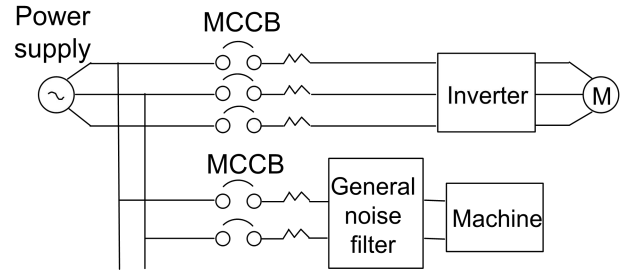
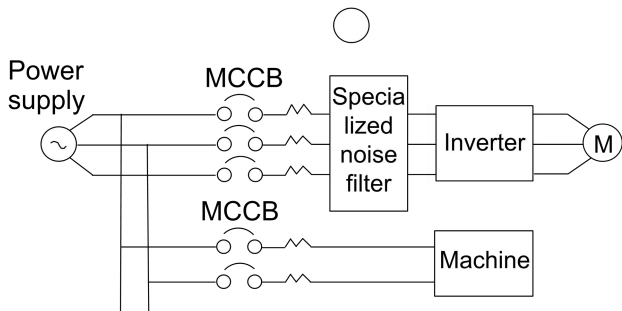

- Interference during transmission can be prohibited by adding an inverter-specialized noise filter at main circuit output side. For preventing electromagnetic radiation, a metal tube shall be installed, and distance from signal wiring of other control machines shall be 30cm at least

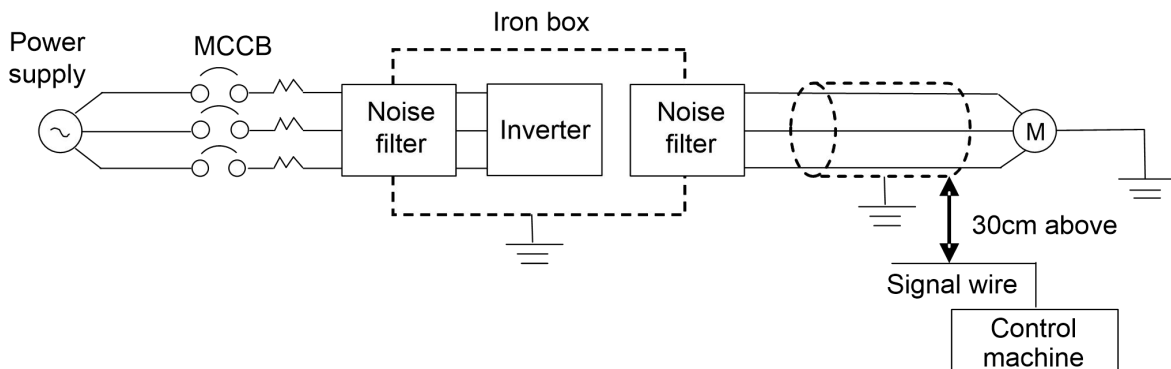

●Voltage drop of wiring shall be considered providing that inverter and motor are with an excessive distance. Voltage drop (V) = $\sqrt{3} \times$ wiring resistance (Ω/km) \times wire length (m) \times current $\times 10^{-3}$, load wave frequency shall be modified according to wiring prepared.

Distance between inverter and motor wiring	Below 50M	Below 100M	Above 100M
Allowable carrier frequency	Below 12kHz	Below 9kHz	Below 6kHz
Set value for parameter 00-10	12	9	6

(B)Wiring for control circuit shall be isolated or far from main circuit wiring or other high voltage/current power lines, thus electromagnetic interference shall be avoided.

●For preventing electromagnetic interference and false sequence, shielding wiring shall be used for control circuit. Shielding wiring shall connect grounding terminals.

Distance for wiring shall be 50m or less.

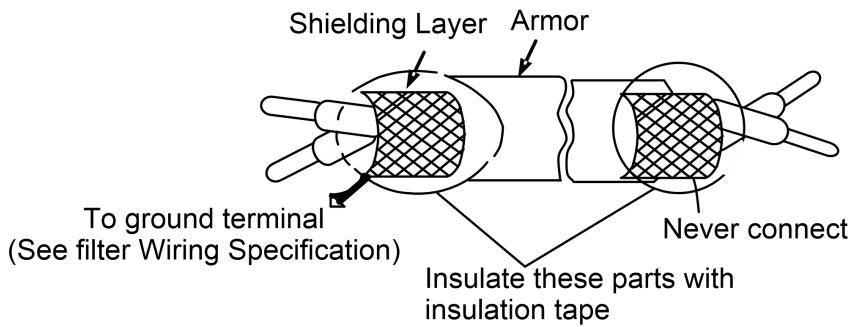

(C) Grounding terminal for inverters shall be grounded properly. 220V:below 100 Ω , Category III;440V:below 10 Ω . Special.

- AWG shall be taken as electrical equipment technical standard for ground wire. Ground wire shall be as short as possible.
- Never ground simultaneously for Inverter ground wire with other large current load (such as welding machine or large Power motors). They shall be grounded separately.
- Ground circuit shall be avoided when several inverters are grounded simultaneously.

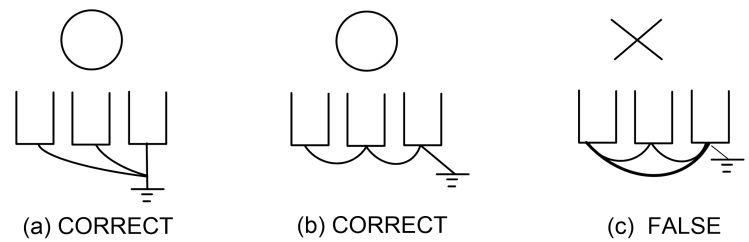

(D)Cable line width for main circuit and control circuit shall be selected according to power line standard.

(E) After completing of grounding and wiring, check for the following items:wiring is proper; wire is not broken and screws are securely locked.

2.4 Basic Wiring Diagram

Wiring of AC motor drive can be divided into two parts, the main circuit and control circuit. After removing the cover, terminals of main circuit and control circuit shall be found. Users must connect terminals as diagram shows.

The following diagram is the standard wiring diagram of S3100L series AC motor driver. If only digital control panel was used, only main circuit terminal wiring applicable.

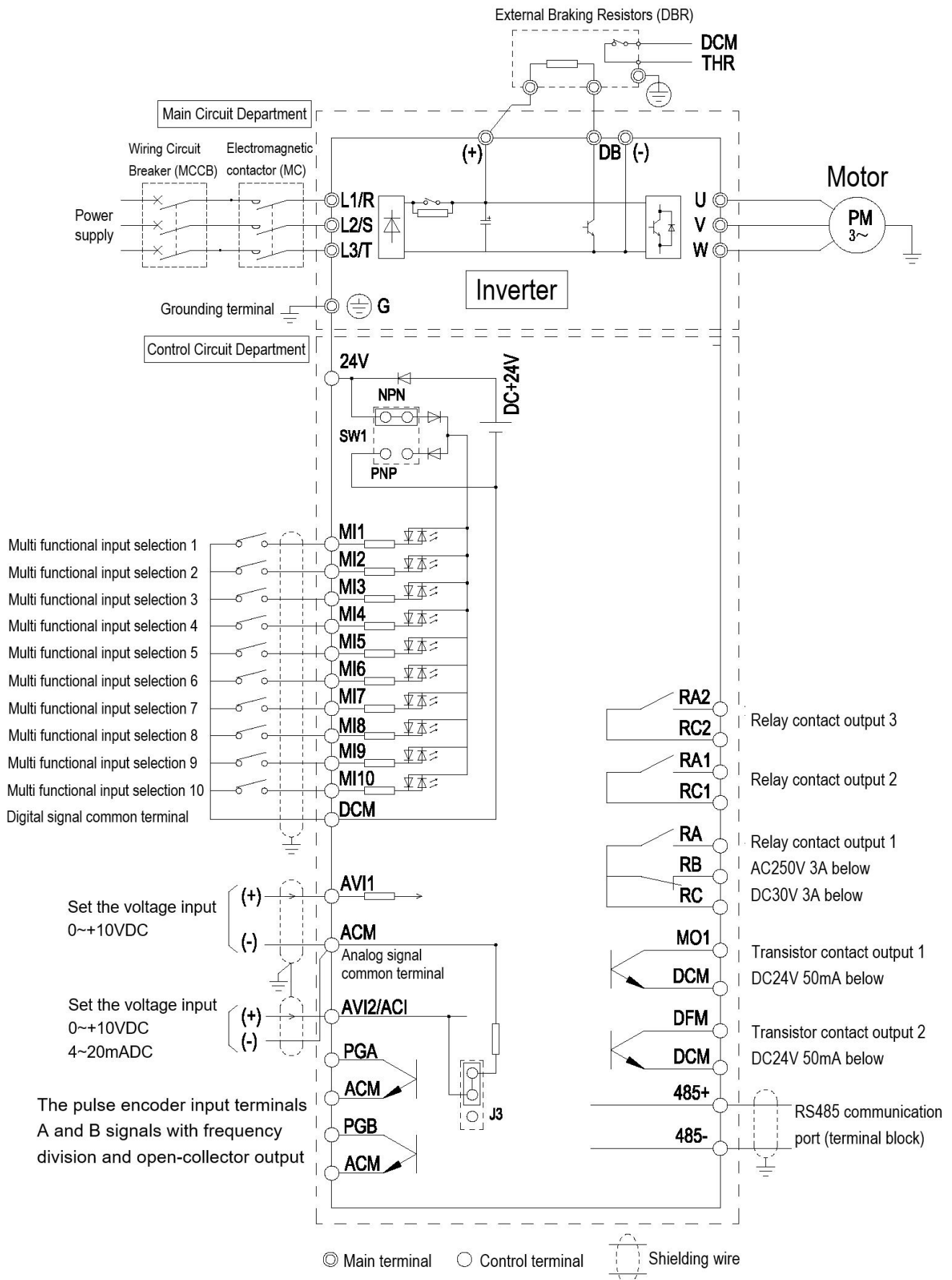

Remarks:

1. The external terminal has two AVI inputs (AVI1, AVI2), one of which is shared with ACI and can be switched to each other.
2. Analog current frequency command ACI:It can switch 4~20mA or 0~+10V as input signal according to J3.
3. The braking unit and braking resistor are selected according to the requirements.

Main Circuit Terminal Descriptions

Description for inverter terminals

Terminal symbols	Function
R/L1,S/L2,T/L3	Main circuit AC power supply input
U/T1,V/T2,W/T3	connect to motor
(+),DB	Braking resistor connecting terminal
(+),(-)	Brake unit connection terminal
	For grounding (High voltage wave impact and noise interference shall be avoided.)

Terminal Symbol Description

Terminal symbols	Function of Terminal	Specification
RA-RC	Multifunctional reference signal output contactor	See description 06-01 for relay contactor output
RB-RC		See description 06-02 for relay contactor output
RA1-RC1		See description 06-03 for relay contactor output
RA2-RC2		See description 06-03 for relay contactor output
MI1-DCM	Multifunctional input option 1	See description from 04-00 to 04-09
MI2-DCM	Multifunctional input option 2	
MI3-DCM	Multifunctional input option 3	
MI4-DCM	Multifunctional input option 4	
MI5-DCM	Multifunctional input option 5	
MI6-DCM	Multifunctional input option 6	
MI7-DCM	Multifunctional input option 7	
MI8-DCM	Multifunctional input option 8	
MI9-DCM	Multifunctional input option 9	
MI10-DCM	Multifunctional input option 10	
MO1-DCM	Multifunctional output terminal 1	See description 06-00(Open collector output)
DFM-DCM	Multifunctional output terminal 2	See description of 06-04(DFM(M) multifunction output)
AVI1-ACM	Analog voltage frequency reference	0 to +10V/Max. output frequency
AVI2-ACM	Analog voltage frequency reference	0 to +10V/Max. output frequency
ACI-ACM	Analog current frequency reference	4 to +20mA/Max. output frequency
485+-485-	Serial connected communication board	RS485 Serial connected communication connector
24V -DCM	Assisted control power supply	DC 20V-24V (50mA Max)

Please insulate the control signal wire with insulation tape.

Only use double Null Modem from communication cable of RS485.

2.5 External Dimensions

2.5.1 Inverter Size

Unit:mm

Model	W	W1	W2	H	H1	D	M	N
S3100L-4T5.5G	180	160	160	298	284	180	6.5	6.5
S3100L-4T7.5G								
S3100L-4T11G								
S3100L-4T15G								
S3100L-4T18.5G								

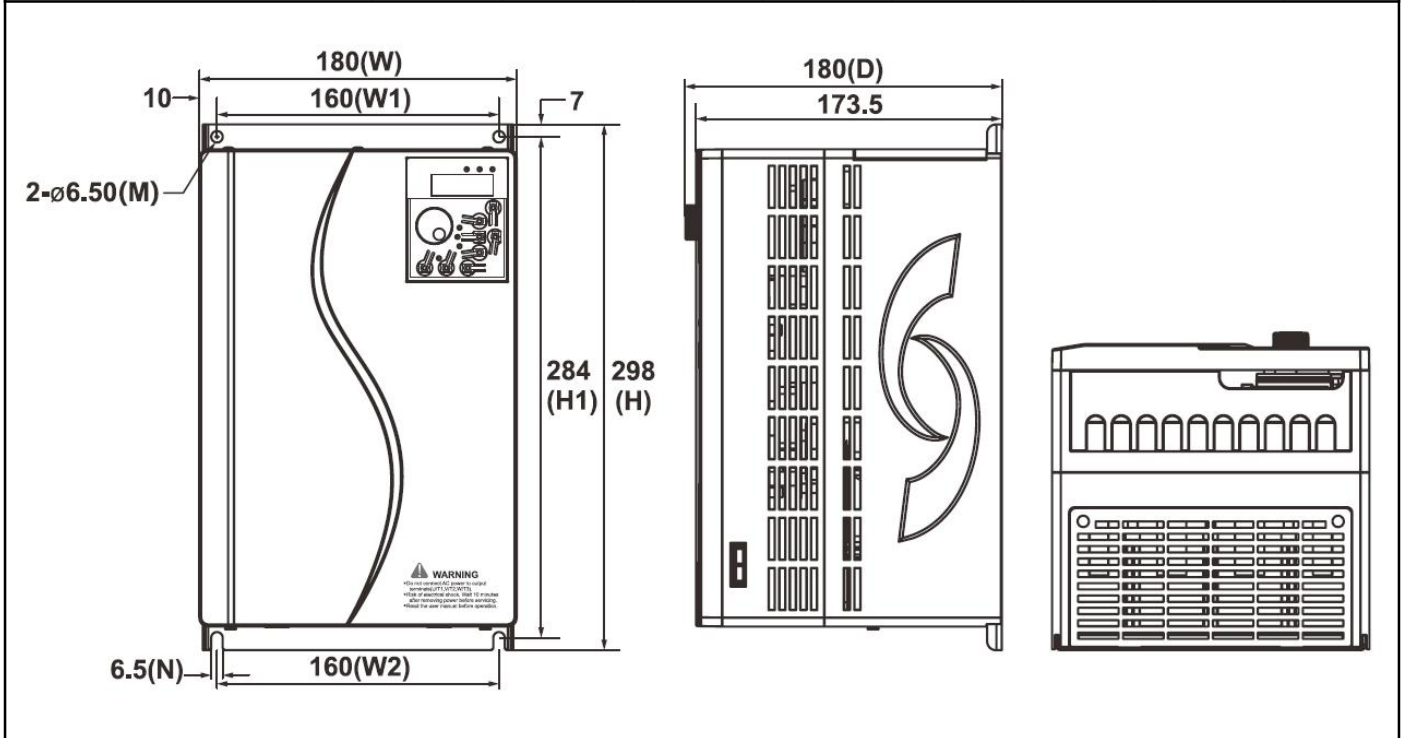

2.5.2 Multi-Functions Operation Keypad

- external dimensions and Installation dimensions

Unit:mm

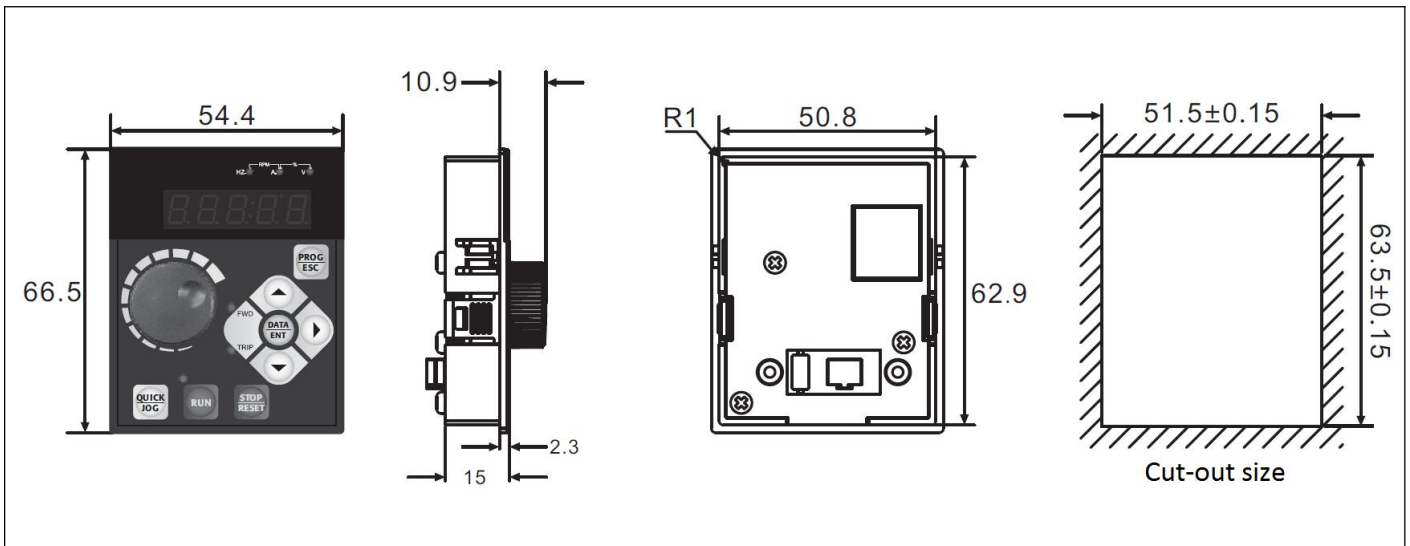

Note: This keyboard can be extended with ordinary network cable (8 cores).

Dimensions of epitaxial supporting box of extending keypad

Unit:mm

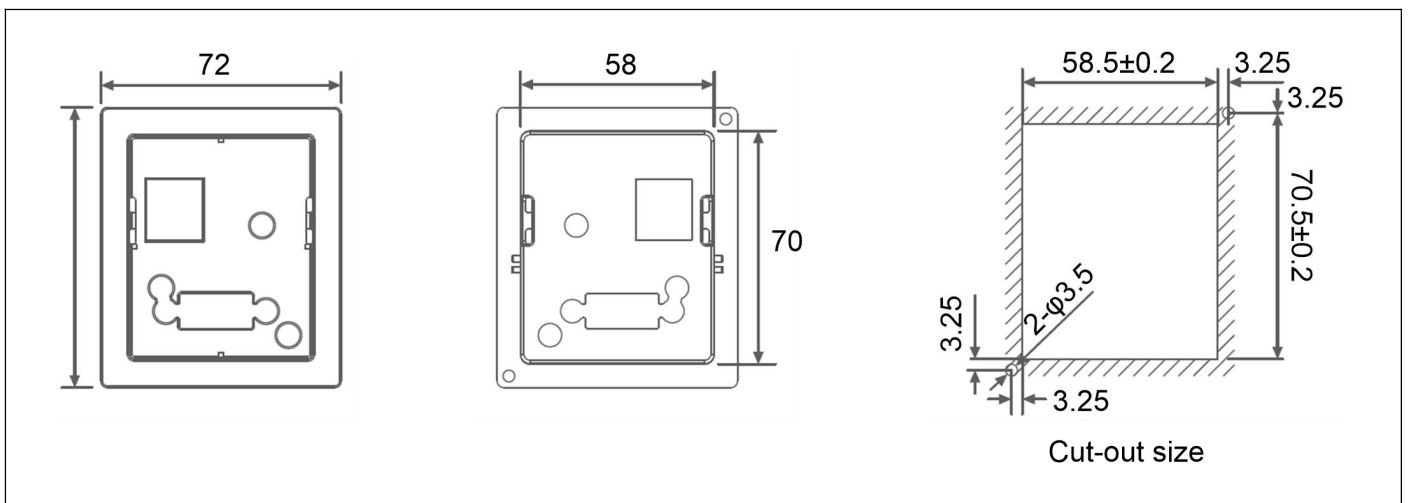

3 KEYPAD DESCRIPTION

3.1 Keyboard Description for Digital Operator

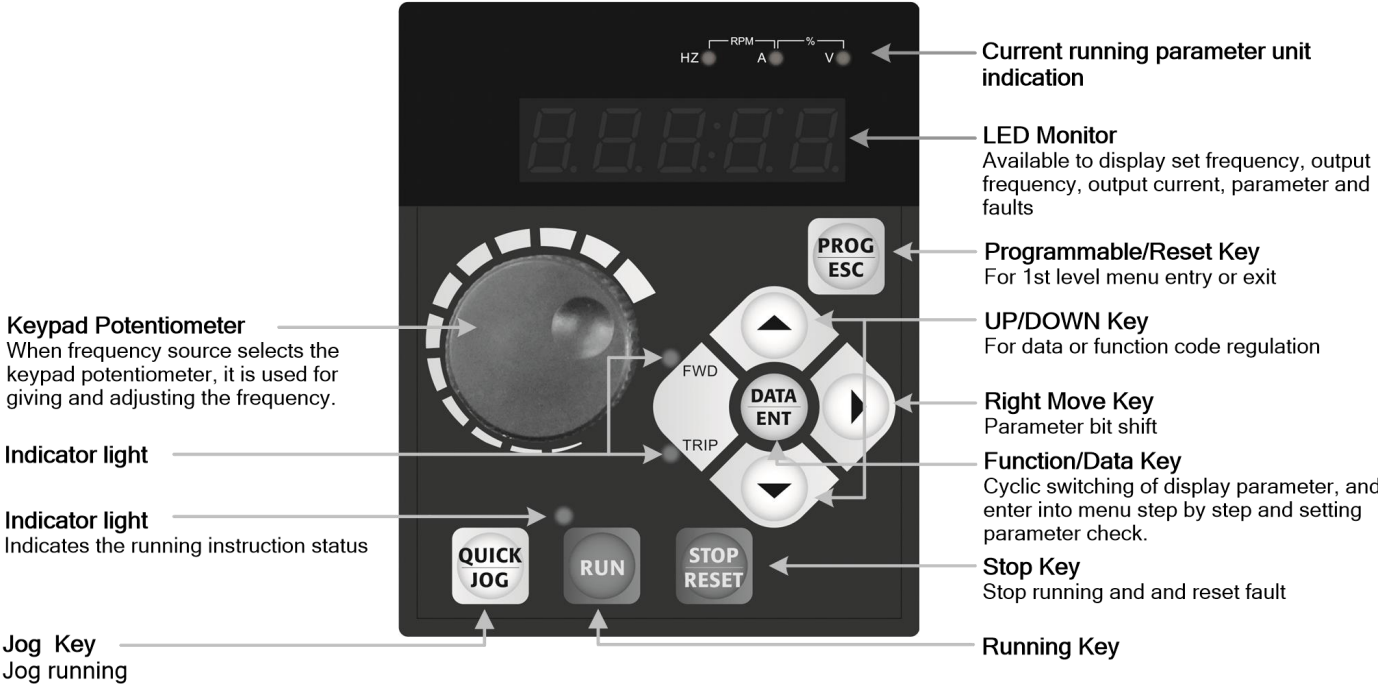

Descriptions and functions of the keyboard

Locating on AC motor drive, the digital operator has two spaces: display space and operating space. Programmed mode and different operation states shall be displayed on the display space, while for the operating space, it is an interface for communication of the operators and AC motor drive.



Functions description of the keyboard

Display and Keyboard		Functions description
	Program key	Enter or quit the first menu
	Enter key	Enter into menu step by step, set parameter
	UP key	Increase of data or function code
	DOWN key	Decrease of data or function code
	Shift key	On stopping and running mode, the parameter can be selected circularly. Able to select the parameter when modifying it

Display and Keyboard		Functions description
	Running key	For start operation under operation keyboard mode
	Stop / reset key	To stop motor in running mode by pressing this key, limited by function code 08-02; To reset fault in the state of fault alarm, free from function code 08-02.
	Shortcut multifunction key	The key is identified by function code 08-01. 0:Jog-run 1:switching key for forward and reverse 2:Clear UP / DOWN setting, clear the frequency value set by UP / DOWN.

Indicator Description

1)Description of function indicator:

Name of indicator	Description of indicator
RUN/TUNE	Operation indicator ON-running OFF-stop FLICKER-parameter self-learning
FWD	Forward & Reverse run indicator: ON-reverse OFF-forward
TRIP	Fault indicator light description: The light on indicates the torque control mode, The slow flashing light indicates auto-tuning, The flashing light indicates a fault state.

2)Description of unit indicator:

symbol	Symbol Description
Hz	Frequency
A	Current
V	Voltage
RPM	Rotating speed
%	Percentage

3.2 Description of Keyboard Operation

3.2.1 Parameter setting

Here are three levels of menu:

- 1.Function code number group (first)
- 2.Function code labeling (second)
- 3.Function code value setting(third)

Note:Press PRG / ESC or DATA / ENT to back to second-level menu when in the third-level. The difference between them is:DATA / ENT key stores the set parameter into control board before backing to second-level menu and shifts to the next function code automatically. While PRG / ESC key backs to the second-level menu directly without storing parameters and keeps the current function code.

For example, set the frequency of function code 07-01 from 00.00Hz to 01.05Hz.

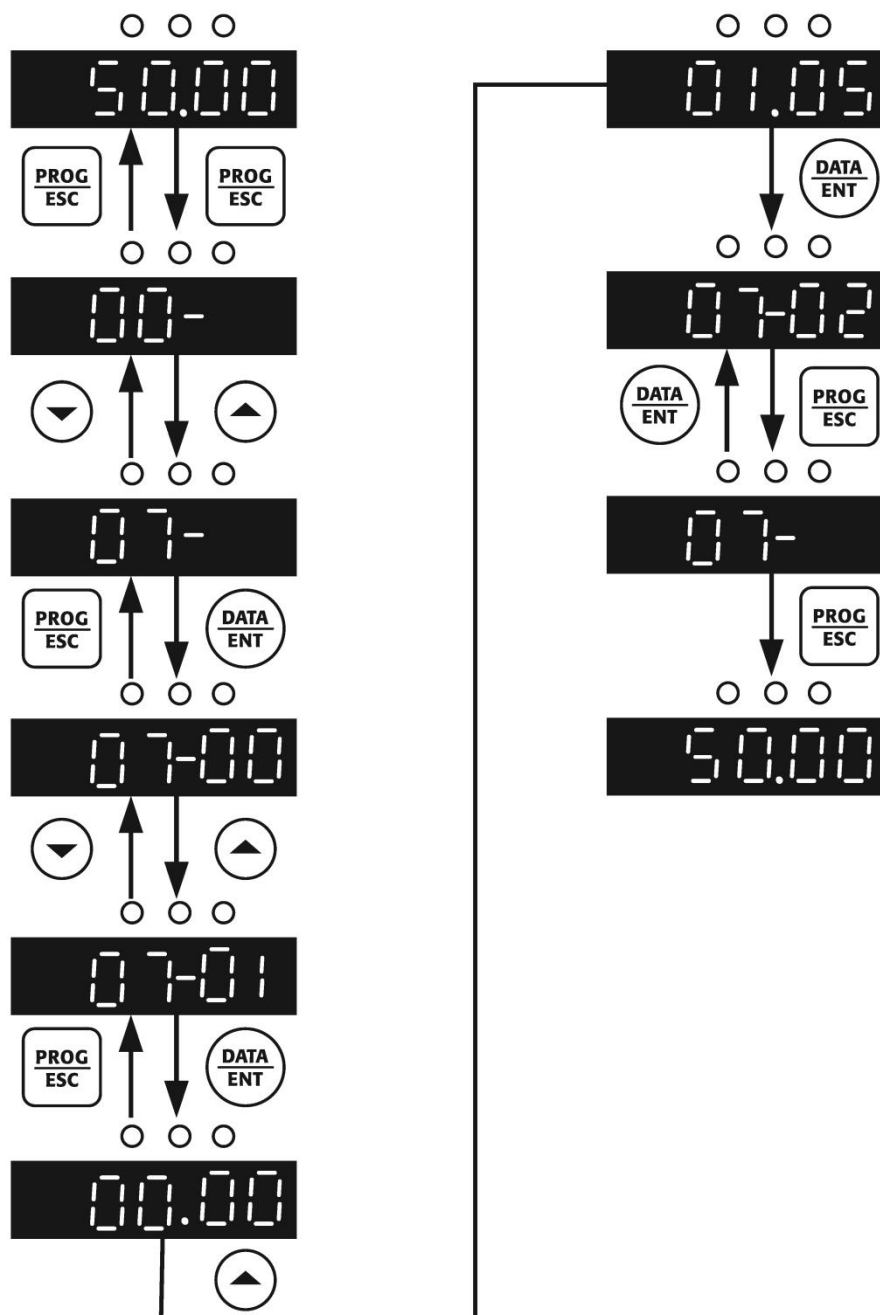

In the state of third-level menu, the function code can't be modified if the indicator does not flicker, the reason of would be:

1)The parameter s of function code can not be modified, e.g. actual detection parameters, operation record parameters, etc.

2)The parameter s of function code can not be modified in running state, the code could be modified only when the motor stops.

3.2.2 Failure Resetting

When the inverter receives a fault, it will display the relative fault information. User can reset the fault by the STOP/RESET key on keyboard or terminal function (group 04). The inverter will be in standby state after fault resetting. If the user doesn't reset when the inverter receives a fault, it will be in running protection state and unable to be operated.

3.2.3 Motor Parameter Self-learning

The nameplate parameter of motor is needed to be input accurately when selecting vector control. The inverter will match the standard motor parameter according to the nameplate parameters. To obtain the excellent control performance, it is recommended to carry out the motor parameters self-learning, the operation step as follows.

First, select the running reference channel (00-00) as the keyboard reference channel .

Then input following parameters according to motor actual parameters.

01-02: motor rated power

01-03: motor rated frequency

01-04: motor rated rotation speed

01-05: motor rated voltage

01-06: motor rated current

During the self-learning process, select the 01-01 self-learning mode and press the DATA / ENT key, the keyboard will display TUNE, and then press the keyboard RUN key, the inverter will drive the motor to perform self-learning for about 2 minutes, the display information disappears, and returns Normal display status indicates that the motor parameter self-learning is completed.

Note: During the process of self-learning, the motor must to be uncoupled from load. Otherwise, incorrect parameters would be obtained. When performing closed-loop static learning with load, set 01-13 to 1 for the auto-tuning.

3.2.4 Password Setting

S3100L series inverters provide user password protection function. When 08-00 is set to non-zero, it is the user password, exit the function code editing state, the password protection is effective, and press PRG / ESC key again to enter the function code editing state, "-----" is displayed. After pressing the DATA / ENT key, the "00000" user password input interface is displayed. The operator must enter the user password correctly, otherwise he cannot enter.

To cancel the password protection function, set 08-00 to 0. The user password does not protect the parameters in the shortcut menu.

Exit the function code editing state, the user password is locked immediately, and the user password is required to enter again.

3.2.5 Running State

3.2.5.1 Power on Initialization

On the course of inverter power on, the system is initialized firstly, LED displays "- - - -" with 7 indicators on. The inverter is in standby state after finishing initialization.

3.2.5.2 Standby

Under stop or running status, various status parameters can be displayed. The function code 08-03 / 08-04 (operation parameter) and 08-05 (stop parameter) can be used to select whether to display this parameter according to the binary digits. Please refer to the descriptions of 08-03, 08-04 and 08-05 for the definition of each bit .

In the stop state, there are multiple stop state parameters that can be selected to be displayed or not, which are: set frequency, bus voltage, switch input state, open collector output state, analog input AVI1 voltage, analog input AVI2 voltage, the load speed are selected by function code 08-05 by bit (converted to binary). ENT + QUICK / JOG key to switch to the left to display selected parameters.

3.2.5.3 Motor Parameters Self-learning

Please see the description of function code 01-01 for details.

3.2.5.4 Operation

In the running state, there are multiple state parameters that can be selected to be displayed or not, respectively: running frequency, set frequency, bus voltage, output voltage, output current, output power, output torque, MI input status, MO output status, AVI1 Voltage, AVI2 voltage, load speed display, operating frequency 2, remaining operating time, voltage before AVI1 correction, voltage before AVI2 / ACI correction, current power-on time, current running time, communication setting value, main frequency X display, auxiliary frequency Y display. Whether to display is selected bit by bit (converted to binary) by function code 08-03 / 08-04, press " > "Key sequence switch to display the selected parameter, press DATA / ENT + QUICK / JOG key to switch to display the selected parameter to the left in order.

3.2.5.5 Alarms

S3100L series inverter provides of alarm information. Please see the alarms and solutions of S3100L series inverter for details.

3.2.6 Quick Debugging

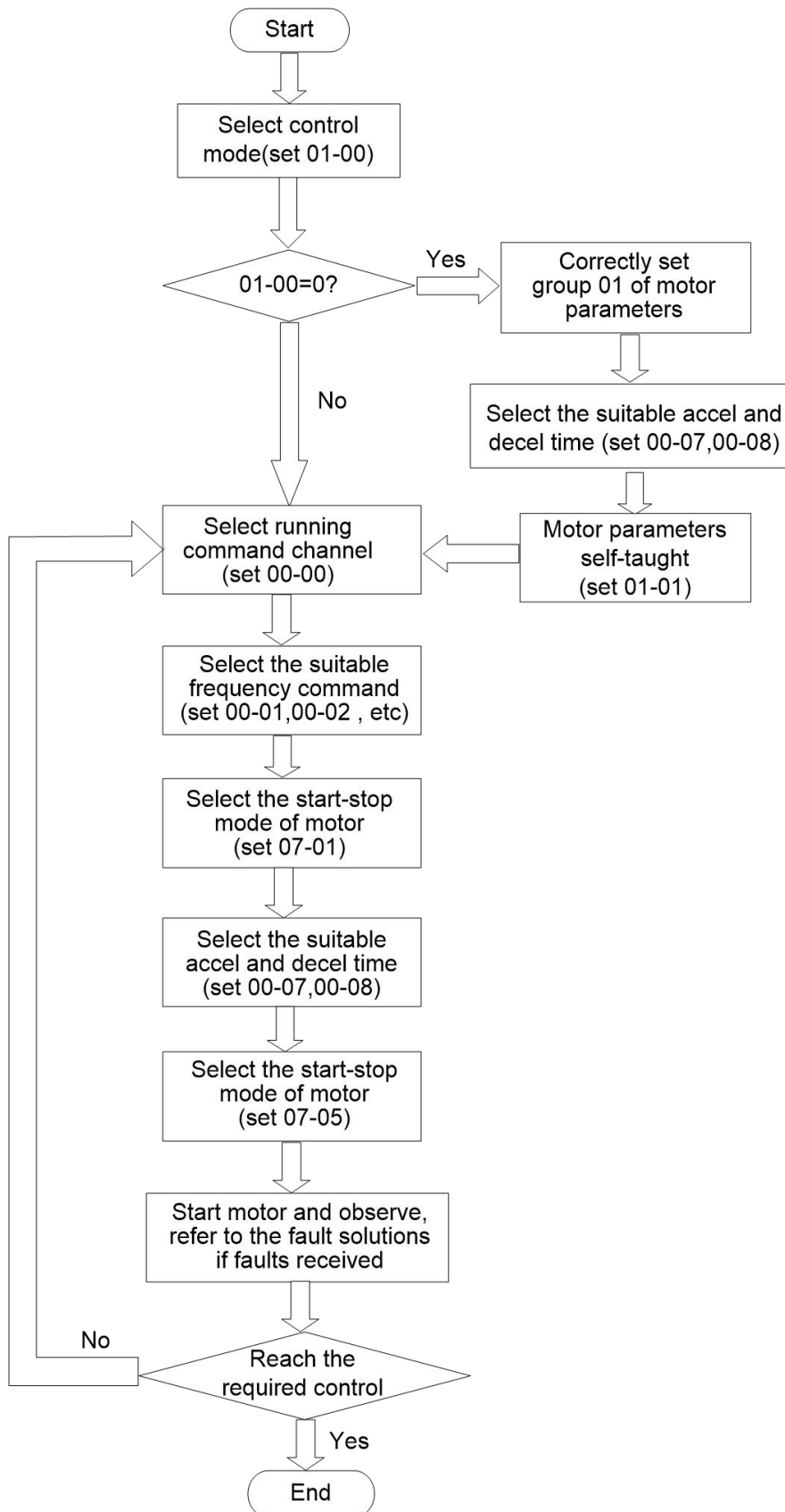

3.3 Preliminary Operation-not Connecting with Motor

- Prior to connecting power supply with AC motor drive, check and make sure that AC power supply voltage is within input voltage range of the drive.
- Connect power supply to R/L1,S/L2 and T/L3 input terminals of the AC motor drive.
- Operation mode control selection.

Operation mode can be divided into the following categories:

- Both frequency command and operation control are determined by keyboard. (00-00=0) (Factory setting)

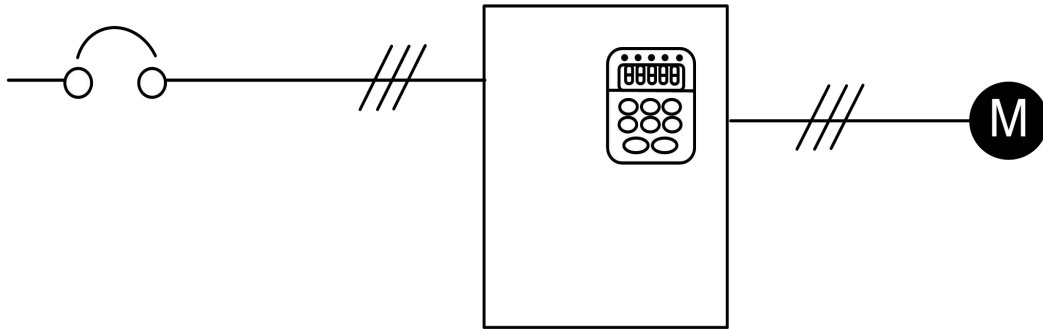

- Frequency command is controlled by keyboard.

Operation command is controlled by external terminals. STOP key on keyboard valid.

Two wire operation control, "FWD/STOP" and "REV/STOP"(04-00=1, 04-01=2, 04-09=0 or 1)

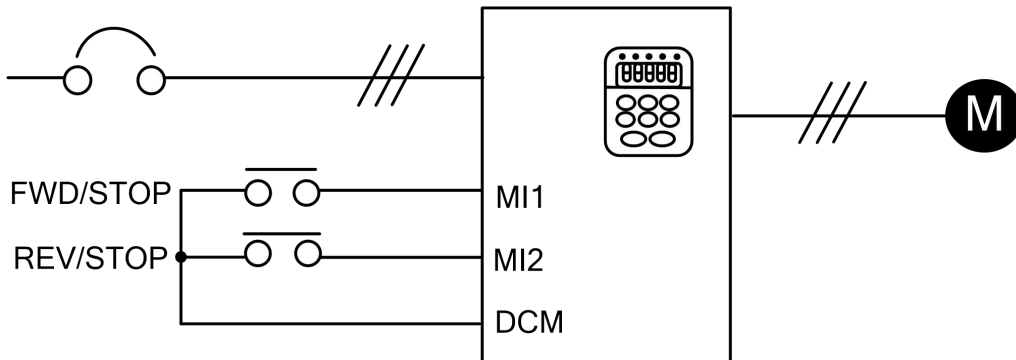

- Frequency command is controlled by keyboard.

Three wire operation control mode Configuration 1 (04-00=1, 04-01=2, 04-02=3, 04-09=2)

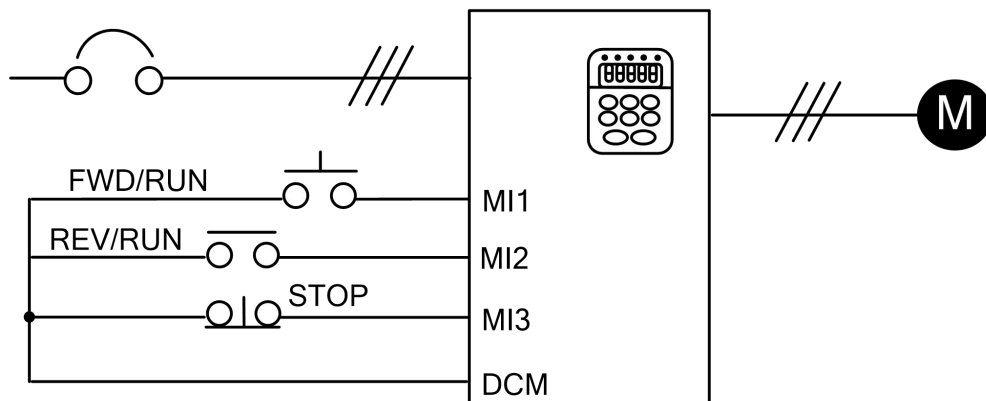

- Frequency command is controlled by keyboard.

Three wire operation control mode Configuration 2 (04-00=1, 04-01=3, 04-02=2, 04-09=3)

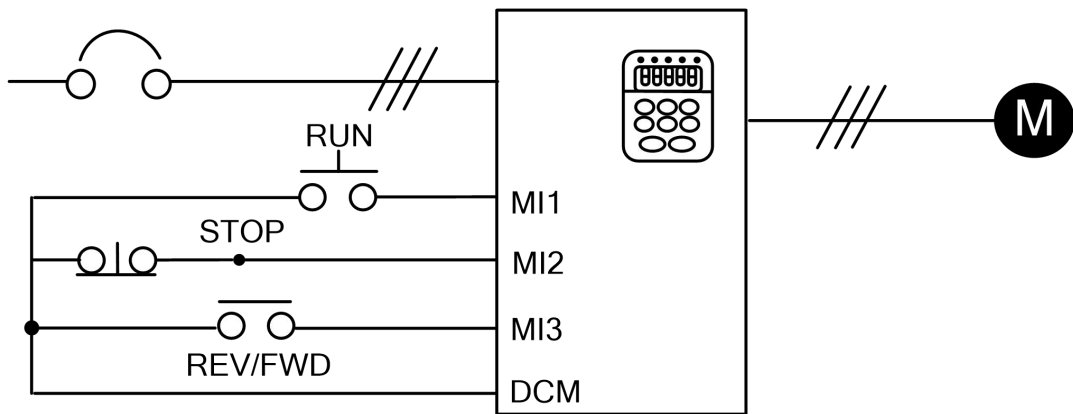

- Frequency command is input by analog signals.

(DC 0 to +10V)+(DC 4 to 20mA)

Operation command is controlled by keyboard.(00-02 is set as 1,2)

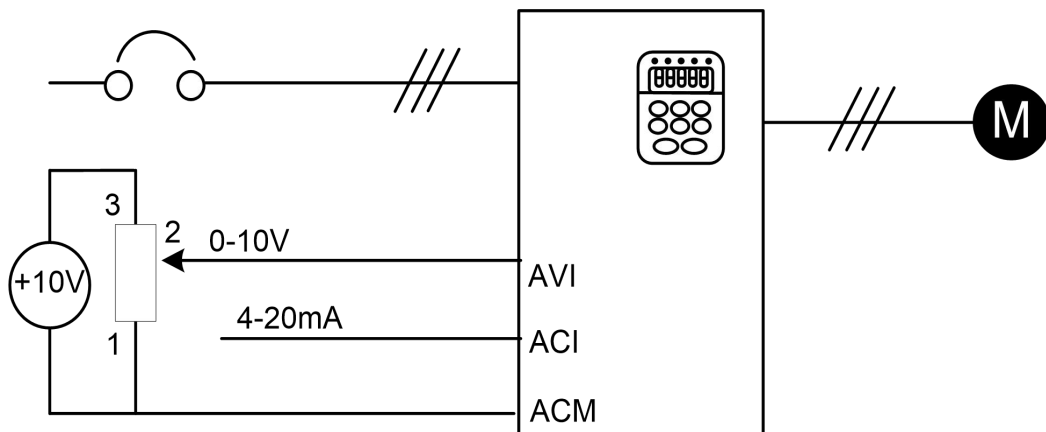

4 FUNCTIONAL PARAMETERS LIST

00 Basic functions parameters		↗ indicates that the parameters can be set during operation		
Parameter	Parameter function	Setting range	Factory setting	
00-00	Command source selection	0:Keyboard command (LED off) 1:Terminal command (LED on) 2:Communication command (LED flicker) 3: Elevator specific (contactor+brake output)	0	↗
00-01	Keyboard and terminal UP / DOWN setting selection	0:Stop memory and power failure storage 1:Stop memory 2:Stop no memory	2	↗
00-02	Main Frequency source selection	0:Digital setting (keyboard given frequency 00-06, UP /DOWN can be modified) 1:AVI1 2:AVI2 / ACI 3:Reserved 4:Multi-speed command 5:Reserved 6:Communication setting 7:Reserved 8:Panel potentiometer 9:Reserved 10: Elevator specific multi-stage speed	1	
00-03	Maximum frequency	50.00Hz~500.00Hz	50.00Hz	
00-04	Upper limitation of running frequency	Lower limit frequency 00-05~max frequency 00-03	50.00Hz	↗
00-05	Lower limitation of running frequency	0.00Hz~Upper limit frequency 00-04	0.00Hz	↗
00-06	Keyboard setting frequency	0.00Hz to the maximum frequency (00-03)	50.00Hz	↗
00-07	Acceleration time 1	0.00s~65000s	Type setting	↗
00-08	Deceleration time 1	0.00s~65000s	Type setting	↗
00-09	Operation direction	0: Reverse 1: Forward	0	↗
00-10	Carrier frequency	0.5kHz~16.0kHz	Type setting	↗
00-11	Parameter initialization	0:No operation 1:Restore factory parameters, excluding motor parameters 2:Clear record information	0	
00-12	Carrier frequency adjusts with temperature	0:no 1:yes	1	↗
00-14	Auxiliary frequency source Y selection	Same as 00-02 (Main frequency source X selection)	0	
00-15	Auxiliary frequency source Y range selection during superposition	0:Relative to the maximum frequency 1:Relative to frequency source X	0	↗
00-16	Auxiliary frequency source Y range when superimposed	0%~150%	100%	↗

00 Basic functions parameters

⚡ indicates that the parameters can be set during operation

Parameter	Parameter function	Setting range	Factory setting	
00-17	Frequency source selection	Single digit:Frequency source selection 0:Main frequency source X 1:Main and auxiliary calculation results (Operation relationship is determined by ten digits) 2:Switch between the main frequency source X and the auxiliary frequency source Y 3:Switch between the main frequency source X and the main and auxiliary calculation results 4:Switch between auxiliary frequency source Y and main and auxiliary calculation results Tens digit:the relationship between the main and auxiliary operations of the frequency source 0:Main+auxiliary 1:Main-auxiliary 2:Maximum of both 3:Minimum of both	0	⚡
00-19	Auxiliary frequency source offset frequency when superimposed	0.00Hz to the maximum frequency (00-03)	0.00Hz	⚡
00-20	Upper frequency source	0:00-04 setting 1:AVI1 2:AVI2 / ACI 3:reserved 4:Reserved 5:Communication given	0	
00-21	Upper frequency offset	0.00Hz~Max frequency 00-03	0.00Hz	⚡
00-22	Acceleration / deceleration time unit	0:1s 1:0.1s 2:0.01s	1	
00-23	Base frequency of acceleration and deceleration time	0:Maximum frequency (00-03) 1:set frequency 2:100Hz	0	
00-24	Base frequency for UP/DOWN command during running	0:Running frequency 1:Set frequency	1	
00-25	Frequency command resolution	1:0.1Hz 2:0.01Hz	2	

01 Motor control parameters

↗ indicates that the parameters can be set during operation

Parameter	Parameter function	Setting range	Factory setting	
01-00	The first motor control mode	0:Speed sensorless vector control (SVC) 1:Vector control with speed sensor (FVC) 2:V/f control	0	
01-01	Motor parameter self-learning	0:No self-learning 11:Synchronous motor static self-learning 12:Synchronous motor complete self-learning	0	
01-02	Motor rated power	0.1kW~1000.0kW	Type setting	
01-03	Motor rated frequency	0.01Hz~max frequency		
01-04	Motor rated rotation speed	1rpm~65535rpm		
01-05	Motor rated voltage	1V~2000V		
01-06	Motor rated current	0.01A~655.35A(inverter power ≤55kW) 0.1A~6553.5A(inverter power >55kW)		
01-12	Motor type selection	2:Permanent magnet synchronous motor	2	
01-13	Learning instruction for sine cosine encoder	1:Static learning	0	
01-16	Stator resistance of synchronous motor	0.001Ω~65.535Ω(inverter power ≤55kW) 0.0001Ω~6.5535Ω(inverter power >55kW)	Type setting	
01-17	D-axis inductance of synchronous motor	0.01mH~655.35mH(inverter power ≤55kW) 0.001mH~65.535mH(inverter power >55kW)		
01-18	Q-axis inductance of synchronous motor	0.01mH~655.35mH(inverter power ≤55kW) 0.001mH~65.535mH(inverter power >55kW)		
01-20	Back-EMF coefficient of synchronous motor	0.1V~6553.5V		
01-27	Encoder pulse number	1~65535	2048	
01-28	Encoder type	0:Reserved 1:sine cosine	1	
01-30	Encoder phase sequence	0:Forward sequence 1:Reverse sequence	0	
01-31	Encoder installation angle	0.0~359.9	0.0	
01-32	Sine and Cosine CD Direction	0:Forward sequence 1:Reverse sequence	0	

02 Vector control parameters

↗ indicates that the parameters can be set during operation

Parameter	Parameter function	Setting range	Factory setting	
02-00	Speed loop proportional gain 1	1~100	20	↗
02-01	Speed loop integration time 1	0.01s~10.00s	0.50s	↗
02-02	Switching frequency 1	0.00~02-05	5.00Hz	↗
02-03	Speed loop proportional gain 2	1~100	20	↗
02-04	Speed loop integration time 2	0.01s~10.00s	1.00s	↗
02-05	Switching frequency 2	02-02~max frequency	10.00Hz	↗
02-06	Vector control slip gain	50%~200%	100%	↗
02-07	Digital setting of torque upper limit in speed control mode	0.0%~200.0%	150.0%	↗
02-08	Speed loop filter time constant	0~31	28	↗
02-09	Vector control over excitation gain	0~200	64	↗

02 Vector control parameters

⚡ indicates that the parameters can be set during operation

Parameter	Parameter function	Setting range	Factory setting	
02-10	Torque upper limit source in speed control mode	0:Parameter 02-07 setting 1:AVI1 2:AVI2 / ACI 3:reserved 4:reserved 5:Communication setting 6:MIN (AVI1, AVI2 / ACI) 7:MAX (AVI1, AVI2 / ACI) The full scale of the 1-7 option corresponds to 02-07	0	⚡
02-13	Excitation adjustment proportional gain	0~60000	3000	⚡
02-14	Excitation adjustment integral gain	0~60000	500	⚡
02-15	Torque adjustment proportional gain	0~60000	3000	⚡
02-16	Torque adjustment integral gain	0~60000	500	⚡
02-17	Reserved		0	⚡
02-18	Field weakening mode of synchronous motor	0,1,2	1	⚡
02-19	Field weakening gain of synchronous motor	0~50	5	⚡
02-22	The upper limit of generating torque becomes effective	0:OFF 1:ON	0	
02-23	Synchronous motor output voltage upper limit margin	0%~50%	5%	⚡
02-24	Synchronous motor initial position angle detection current	10%~180%	80%	⚡
02-25	Synchronous motor initial position angle detection	0:Check every run 1:Not check 2:Power-on first run detection	0	⚡
02-26	Speed mode	0:Mode 0 1:Mode 1	0	
02-32	Z signal calibration enabling	0:OFF 1:ON	0	
02-36	Low speed excitation current	0~80%	30%	⚡
02-37	Low speed carrier frequency	0.8K~00-10	6.0K	⚡
02-43	Zero speed enabling	0~1	0	⚡
02-44	Switchover frequency	0.00~02-02	0.30Hz	⚡
02-45	Zero speed KP	1~100	10	⚡
02-46	Zero speed TI	0.01s~10.00s	0.50s	⚡
02-49	Auto-tuning mode	0,1,2	0	⚡
02-51	Initial position compensation angle	0.0°~360.0	0.0	⚡

03 V/f control parameters

⚡ indicates that the parameters can be set during operation

Parameter	Parameter function	Setting range	Factory setting	
03-00	V/f curve setting	0: Straight line V/f 1: Multi-point V/f	0	
03-01	Torque boost	0.0%:(auto-torque boost) 0.1%~30.0%	Type setting	⚡
03-02	Cut-off frequency of torque boost	0.00Hz~max frequency	50.00Hz	
03-03	Multi-point V/f frequency 1	0.00Hz~03-05	0.00Hz	
03-04	Multi-point V/f voltage 1	0.0%~100.0%	0.0%	
03-05	Multi-point V/f frequency 2	03-03~03-07	0.00Hz	
03-06	Multi-point V/f voltage 2	0.0%~100.0%	0.0%	
03-07	Multi-point V/f frequency 3	03-05~motor rated frequency(01-03)	0.00Hz	
03-08	Multi-point V/f voltage 3	0.0%~100.0%	0.0%	
03-09	V/f slip compensation gain	0.0%~200.0%	0.0%	⚡
03-10	V/f overexcitation gain	0~200	64	⚡
03-11	V/f oscillation suppression gain	0~100	Type setting	⚡
03-18	Over current stall action current	50~200%	150%	
03-19	Overflow rate enable	0: invalid 1: valid	1	
03-20	Over-current stall suppression gain	0~100	20	⚡
03-21	Double-speed over-current stall action current compensation coefficient	50~200%	50%	
03-22	Overvoltage stall action voltage	330.0V~800.0V	380V:760.0 220V:370.0	
03-23	Overvoltage stall enable	0: invalid 1: valid	1	
03-24	Overvoltage stall suppression frequency gain	0~100	30	⚡
03-25	Overvoltage stall suppression voltage gain	0~100	30	⚡
03-26	Overvoltage stall maximum rise frequency limit	0~50Hz	5Hz	

04 Input terminal parameters

⚡ indicates that the parameters can be set during operation

Parameter	Parameter function	Setting range	Factory setting	
04-00	MI1 terminal function selection	0: No function	1	
04-01	MI2 terminal function selection	1: Forward running (FWD)	2	
04-02	MI3 terminal function selection	2: Reverse running (REV)	9	
04-03	MI4 terminal function selection	3: Three-wire control	0	
04-04	MI5 terminal function selection	4: Forward Jog (FJOG)	0	
04-05	MI6 terminal function selection	5: Reverse jog (RJOG)	0	
04-06	MI7 terminal function selection	6: Terminal UP	0	
04-07	MI8 terminal function selection	7: Terminal DOWN	0	
04-08	MI9 terminal function selection	8: Coast to stop	0	
		9: Fault reset (RESET)	0	
		10: Run pause	0	

04 Input terminal parameters

↗ indicates that the parameters can be set during operation

Parameter	Parameter function	Setting range	Factory setting	
04-09	MI10 terminal function selection	11:Normally open input for external fault 12:Multi-step speed command terminal 1 13:Multi-step speed command terminal 2 14:Multi-step speed command terminal 3 15:Multi-step speed command terminal 4 16:Acceleration / deceleration time selection terminal 1 17:Acceleration / deceleration time selection terminal 2 18:Frequency source switching 19:UP / DOWN set to cleared (Terminal, keyboard) 20:Run command switching terminal 21:Acceleration / deceleration prohibited 22-28:reserved 29:Torque control prohibited 30:reserved 31:reserved 32:Immediate DC braking 33:Normally closed input for external fault 34:Frequency modification enable 35:reserved 36:External stop terminal 1 37:Control command switching terminal 2 38:reserved 39:Frequency source X and keyboard set frequency switching 40:Frequency source Y and keyboard set frequency switching 41:Reserved 42:Reserved 43:reserved 44:Reserved 45:reserved 46:Speed control / torque control switching 47:Emergency stop 48:External stop terminal 2 49:Deceleration DC braking 50:Clear the current running time 51-52:reserved 53:Contactor output feedback 54:Brake output feedback 55:En enabling 56:Emergency power 57-63:reserved	0	
04-10	MI Filter time	0.000s~1.000s	0.010s	↗
04-11	Terminal command mode	0:Two-wire 1 1:Two-wire 2 2:Three-wire 1 3:Three-wire 2	0	
04-12	Terminal UP / DOWN change rate	0.001Hz/s~65.535Hz/s	1.00Hz/s	↗
04-13	AVI curve 1 lower limit	0.00V~04-15	0.10V	↗

04 Input terminal parameters

↗ indicates that the parameters can be set during operation

Parameter	Parameter function	Setting range	Factory setting	
04-14	Corresponding setting of AVI curve 1 lower limit	-100.0%~+100.0%	0.0%	↗
04-15	AVI curve 1 upper limit	04-13~+10.00V	10.00V	↗
04-16	Corresponding setting of AVI curve 1 upper limit	-100.0%~+100.0%	100.0%	↗
04-17	AVI1 filter time	0.00s~10.00s	0.10s	↗
04-18	AVI curve 2 lower limit	0.00V~04-20	0.10V	↗
04-19	Corresponding setting of AVI curve 2 lower limit	-100.0%~+100.0%	0.0%	↗
04-20	AVI curve 2 upper limit	04-18~+10.00V	10.00V	↗
04-21	Corresponding setting of AVI curve 2 upper limit	-100.0%~+100.0%	100.0%	↗
04-22	AVI2/ACI filter time	0.00s~10.00s	0.10s	↗
04-33	AVI curve selection	Single digit:AVI1 curve selection 1:AVI curve 1 (2 points, see 04-11~04-14) 2:AVI curve 2 (2 points, see 04-16~04-19) 3:Reserved 4:Reserved 5:Reserved Tenth digit:AVI2 / ACI curve selection, same as above Hundreds digit:Reserved	321	↗
04-34	AVI is less than the minimum input setting selection	Single digit:AVI1 is below the minimum input setting selection 0:Corresponds to the minimum input setting 1:0.0% Tens digit:AVI2 / ACI is lower than the minimum input setting selection, same as above	000	↗
04-35	MI1 delay time	0.0s~3600.0s	0.0s	↗
04-36	MI2 delay time	0.0s~3600.0s	0.0s	↗
04-37	MI3 delay time	0.0s~3600.0s	0.0s	↗
04-38	MI terminal valid mode selection 1	0:High level valid 1:Low level valid Single digit:MI1 Tens digit:MI2 Hundreds digit :MI3 Thousands digit:MI4 Tens of thousands digit :MI5	0	
04-39	MI terminal valid mode selection 2	0:High level valid 1:Low level valid Single digit:MI6 Tens digit:MI7 Hundreds digit :MI8 Thousands digit:MI9 Tens of thousands digit :MI10	0	

05 Multi-speed

↗ indicates that the parameters can be set during operation

Parameter	Parameter function	Setting range	Factory setting		
05-00	Multi-speed command 0	0.00Hz~00-03	0.00Hz	↗	
05-01	Multi-speed command 1	0.00Hz~00-03	0.00Hz	↗	
05-02	Multi-speed command 2	0.00Hz~00-03	0.00Hz	↗	
05-03	Multi-speed command 3	0.00Hz~00-03	0.00Hz	↗	
05-04	Multi-speed command 4	0.00Hz~00-03	0.00Hz	↗	
05-05	Multi-speed command 5	0.00Hz~00-03	0.00Hz	↗	
05-06	Multi-speed command 6	0.00Hz~00-03	0.00Hz	↗	
05-07	Multi-speed command 7	0.00Hz~00-03	0.00Hz	↗	
05-08	Multi-speed command 8	0.00Hz~00-03	0.00Hz	↗	
05-09	Multi-speed command 9	0.00Hz~00-03	0.00Hz	↗	
05-10	Multi-speed command 10	0.00Hz~00-03	0.00Hz	↗	
05-11	Multi-speed command 11	0.00Hz~00-03	0.00Hz	↗	
05-12	Multi-speed command 12	0.00Hz~00-03	0.00Hz	↗	
05-13	Multi-speed command 13	0.00Hz~00-03	0.00Hz	↗	
05-14	Multi-speed command 14	0.00Hz~00-03	0.00Hz	↗	
05-15	Multi-speed command 15	0.00Hz~00-03	0.00Hz	↗	
05-18	Multi-speed Command 0: S Curve Ratio Selection	0:07-12/07-13 2:24-06/24-07	1:24-04/24-05 3:24-08/24-09	0	↗
05-19	Multi-speed command 0: Acceleration and deceleration time selection	0:00-07/00-08 2:09-05/09-06	1:09-03/09-04 3:09-07/09-08	0	↗
05-20	Multi-speed Command 1: S Curve Ratio Selection	Same as 05-18		0	↗
05-21	Multi-speed command 1: Acceleration and deceleration time selection	Same as 05-19		0	↗
05-22	Multi-speed Command 2: S Curve Ratio Selection	Same as 05-18		0	↗
05-23	Multi-speed command 2: Acceleration and deceleration time selection	Same as 05-19		0	↗
05-24	Multi-speed Command 3: S Curve Ratio Selection	Same as 05-18		0	↗
05-25	Multi-speed command 3: Acceleration and deceleration time selection	Same as 05-19		0	↗
05-26	Multi-speed Command 4: S Curve Ratio Selection	Same as 05-18		0	↗
05-27	Multi-speed command 4: Acceleration and deceleration time selection	Same as 05-19		0	↗
05-28	Multi-speed Command 5: S Curve Ratio Selection	Same as 05-18		0	↗
05-29	Multi-speed command 5: Acceleration and deceleration time selection	Same as 05-19		0	↗
05-30	Multi-speed Command 6: S Curve Ratio Selection	Same as 05-18		0	↗
05-31	Multi-speed command 6: Acceleration and deceleration time selection	Same as 05-19		0	↗

05 Multi-speed

↗ indicates that the parameters can be set during operation

Parameter	Parameter function	Setting range	Factory setting	
05-32	Multi-speed Command 7: S Curve Ratio Selection	Same as 05-18	0	↗
05-33	Multi-speed command 7: Acceleration and deceleration time selection	Same as 05-19	0	↗
05-34	Multi-speed Command 8: S Curve Ratio Selection	Same as 05-18	0	↗
05-35	Multistage speed command 8: Acceleration and deceleration time selection	Same as 05-19	0	↗
05-36	Multi-speed Command 9: S Curve Ratio Selection	Same as 05-18	0	↗
05-37	Multi-speed command 9: Acceleration and deceleration time selection	Same as 05-19	0	↗
05-38	Multi-speed Command 10: S Curve Ratio Selection	Same as 05-18	0	↗
05-39	Multi-speed command 10: Acceleration and deceleration time selection	Same as 05-19	0	↗
05-40	Multi-speed Command 11: S Curve Ratio Selection	Same as 05-18	0	↗
05-41	Multi-speed command 11: Acceleration and deceleration time selection	Same as 05-19	0	↗
05-42	Multi-speed Command 12: S Curve Ratio Selection	Same as 05-18	0	↗
05-43	Multi-speed command 12: Acceleration and deceleration time selection	Same as 05-19	0	↗
05-44	Multi-speed Command 13: S Curve Ratio Selection	Same as 05-18	0	↗
05-45	Multi-speed command 13: Acceleration and deceleration time selection	Same as 05-19	0	↗
05-46	Multi-speed Command 14: S Curve Ratio Selection	Same as 05-18	0	↗
05-47	Multi-speed command 14: Acceleration and deceleration time selection	Same as 05-19	0	↗
05-48	Multi-speed Command 15: S Curve Ratio Selection	Same as 05-18	0	↗
05-49	Multi-speed command 15: Acceleration and deceleration time selection	Same as 05-19	0	↗
05-51	Multi-step speed command 0 given mode	0:Parameter 05-00 given 1:AVI1 2:AVI2 / ACI 3:reserved 4:reserved 5:reserved 6:The keyboard setting frequency (00-06) is given, UP /DOWN can be modified	0	↗

06 Output terminal parameters

⚡ indicates that the parameters can be set during operation

Parameter	Parameter function	Setting range	Factory setting	
06-00	MO1 output function selection	0:No output	1	⚡
06-01	RA-RB-RC output function selection	1:Inverter is running 2:Fault output (stop)	2	⚡
06-02	RA1-RC1 output function selection	3:Frequency level detection FDT1 output 4:Frequency reached	0	⚡
06-03	RA2-RC2 output function selection	5:Running at zero speed (no output when stopped) 6:Motor overload pre-alarm	0	⚡
06-04	DFM (M) output function selection	7:Inverter overload pre-alarm 8:reserved 9:reserved 10:reserved 11:reserved 12:Cumulative running time arrived 13:Frequency limited 14:Torque limited 15:Ready for run 16:AVI1> AVI2 / ACI 17:Upper limit frequency reached 18:Lower limit frequency reached (operation valid) 19:Undervoltage state output 20:Communication setting 21:reserved 22:reserved 23:Zero speed running 2 (also output when stopped)	0	⚡
		24:Cumulative power-on time arrived 25:Frequency level detection FDT2 output 26:Frequency 1 reaches the output 27:Frequency 2 reaches the output 28:Current 1 reaches the output 29:Current 2 reaches the output 30:Timing reached 31:AVI1 input exceeds limit 32:Lost load 33:Reverse running 34:Zero current state 35:Module temperature reached 36:Output current exceeded 37:Lower limit frequency reached (also output when stopped) 38:Warning output (continued) 39:reserved 40:Current running time reached 42:Contactor output 43:Brake output	0	⚡
06-05	DFM terminal output mode selection	0:Reserved 1:Switch output (DFM (M))	1	⚡
06-17	MO1 output delay time	0.0s~3600.0s	0.0s	⚡
06-18	Relay RA-RB-RC output delay time	0.0s~3600.0s	0.0s	⚡
06-19	Relay RA1-RC1 output delay time	0.0s~3600.0s	0.0s	⚡
06-20	Relay RA2-RC2 output delay time	0.0s~3600.0s	0.0s	⚡

07 Start and stop control parameters

↗ indicates that the parameters can be set during operation

Parameter	Parameter function	Setting range	Factory setting	
07-00	Startup mode	0:Direct start 1:Rotation speed tracking restart 2:Pre-excitation start	0	↗
07-01	Startup frequency	0.00Hz~10.00Hz	0.00Hz	↗
07-02	Startup frequency holding time	0.0s~100.0s	0.0s	
07-03	Startup DC braking current / pre-excitation current	0%~100%	0%	
07-04	Startup DC braking time / pre-excitation time	0.0s~100.0s	0.0s	
07-05	Stop mode	0:Decelerate to stop 1:Coast to stop	0	↗
07-06	Starting DC braking frequency at stop	0.00Hz~max frequency	0.00Hz	↗
07-07	DC braking waiting time at stop	0.0s~100.0s	0.0s	↗
07-08	DC braking current at stop	0%~100%	0%	↗
07-09	DC braking time at stop	0.0s~100.0s	0.0s	↗
07-10	Brake usage	0%~100%	80%	↗
07-11	Acceleration and deceleration mode	0:linear acceleration / deceleration 1:S curve acceleration and deceleration A 5:S curve acceleration / deceleration B	0	
07-12	S curve start time ratio 1	0.0%~(100.0%-07-13)	30.0%	
07-13	S curve end time ratio 1	0.0%~(100.0%-07-12)	30.0%	

08 Man-machine interface parameters

↗ indicates that the parameters can be set during operation

Parameter	Parameter function	Setting range	Factory setting	
08-00	User password	0~65535	0	↗
08-01	QUICK/JOG key function selection	0:QUICK/JOG invalid 1:Keyboard command channel and remote command channel (terminal Terminal command channel or communication command channel) switch 2:Forward and reverse switching 3:Forward jog 4:Reverse jog	3	
08-02	STOP/RESET key function	0:Only in the keyboard operation mode, the STOP/RESET key stop function is effective 1:In any operation mode, the STOP/RESET key stop function is effective	1	↗

08 Man-machine interface parameters

⚡ indicates that the parameters can be set during operation

Parameter	Parameter function	Setting range	Factory setting	
08-03	LED operation display parameter 1	0000~FFFF Bit00:Running frequenc 1(Hz) Bit01:Setting frequency(Hz) Bit02:BUS Voltage(V) Bit03:Output voltage(V) Bit04:Output current(A) Bit05:Output power(kW) Bit06:Output torque(%) Bit07:MI input status Bit08:MO output status Bit09:AVI1 voltage(V) Bit10:AVI2/ACI voltage(V) Bit11:Reserved Bit12:Reserved Bit13:Reserved Bit14:Load speed Bit15:Reserved	1F	⚡
08-04	LED operation display parameter 2	0000~FFFF Bit00:Reserved Bit01:Reserved Bit02:Reserved Bit03:Running frequenc 2(Hz) Bit04:Remaining running time Bit05:AVI1 voltage before correction(V) Bit06:AVI2/ACI voltage before correction(V) Bit07:Reserved Bit08:Reserved Bit09:Current power-on time(Hour) Bit10:Current running time(Min) Bit11:Reserved Bit12:Communication setting value Bit13:Reserved Bit14:Main frequency X display (Hz) Bit15:Auxiliary frequency Y display(Hz)	0	⚡
08-05	LED shutdown display parameters	0000~FFFF Bit00:Setting frequency(Hz) Bit01:BUS voltage(V) Bit02:MI input status Bit03:MO output status Bit04:AVI1 voltage(V) Bit05:AVI2/ACI voltage(V) Bit06:Reserved Bit07:Reserved Bit08:Reserved Bit09:Reserved Bit10:Load speed Bit11:Reserved Bit12:Reserved	33	⚡
08-06	Load speed display coefficient	0.0001~6.5000	1.0000	⚡
08-07	Reserved		-	
08-08	Inverter module radiator	0.0℃~100.0℃	-	

08 Man-machine interface parameters

↗ indicates that the parameters can be set during operation

Parameter	Parameter function	Setting range	Factory setting	
	temperature			
08-09	Reserved	-	-	
08-10	Software version No.	-	-	
08-11	Cumulative running time	0h~65535h	-	
08-12	Load speed display the number of decimal places	Units: Number of decimal places for load speed Tens place: Number of decimal places for feedback speed 0:0 decimal place 1:1 decimal place 2:2 decimal places 3:3 decimal places	21	↗
08-13	Cumulative power-on time	0h~65535h	-	
08-14	Cumulative power consumption	0~65535 degree	-	

09 Accessibility parameters

↗ indicates that the parameters can be set during operation

Parameter	Parameter function	Setting range	Factory setting	
09-00	Jog running frequency	0.00Hz~max frequency	5.00Hz	↗
09-01	Jog acceleration time	0.0s~6500.0s	20.0s	↗
09-02	Jog deceleration time	0.0s~6500.0s	20.0s	↗
09-03	Acceleration time 2	0.0s~6500.0s	Type setting	↗
09-04	Deceleration time 2	0.0s~6500.0s		↗
09-05	Acceleration time 3	0.0s~6500.0s		↗
09-06	Deceleration time 3	0.0s~6500.0s		↗
09-07	Acceleration time 4	0.0s~6500.0s		↗
09-08	Deceleration time 4	0.0s~6500.0s		↗
09-09	Jump frequency 1	0.00Hz~max frequency		0.00Hz
09-10	Jump frequency 2	0.00Hz~max frequency	0.00Hz	↗
09-11	Jump frequency Amplitude	0.00Hz~max frequency	0.00Hz	↗
09-12	Forward and reverse dead time	0.0s~3000.0s	0.0s	↗
09-13	Reverse control enable	0:Enabled 1:Disabled	0	↗
09-14	Operating mode with set frequency lower than lower limit frequency	0:Run at the lower limit frequency 1:Downtime 2:Zero speed operation	0	↗
09-15	Drop control	0.00Hz~10.00Hz	0.00Hz	↗
09-16	Set cumulative power-on arrival time	0h~65000h	0h	↗
09-17	Set cumulative running arrival time	0h~65000h	0h	↗
09-18	Power-on operation protection options	0:Run command is valid when power on 1:Run command is invalid when power on	1	↗
09-19	Frequency detection value(FDT1)	0.00Hz~max frequency	50.00Hz	↗
09-20	Frequency detection hysteresis(FDT1)	0.0%~100.0%(FDT1 Level)	5.0%	↗

09 Accessibility parameters

↗ indicates that the parameters can be set during operation

Parameter	Parameter function	Setting range	Factory setting	
09-21	Frequency reach detection width	0.0%~100.0%(max frequency)	0.0%	↗
09-22	Whether the jump frequency is effective during acceleration and deceleration	0:Invalid 1:Valid	0	↗
09-25	Switching frequency point between acceleration time 1 and acceleration time 2	0.00Hz~max frequency	0.00Hz	↗
09-26	Switching frequency point between deceleration time 1 and deceleration time 2	0.00Hz~max frequency	0.00Hz	↗
09-27	Terminal jogging priority	0:Invalid 1:Valid	0	↗
09-28	Frequency detection value(FDT2)	0.00Hz~max frequency	50.00Hz	↗
09-29	Frequency detection hysteresis(FDT2)	0.0%~100.0%(FDT2 Level)	5.0%	↗
09-30	Arbitrary arrival frequency detection value 1	0.00Hz~max frequency	50.00Hz	↗
09-31	Arbitrary arrival frequency detection width 1	0.0%~100.0%(max frequency)	0.0%	↗
09-32	Arbitrary arrival frequency detection value 2	0.00Hz~max frequency	50.00Hz	↗
09-33	Arbitrary arrival frequency detection width 2	0.0%~100.0%(max frequency)	0.0%	↗
09-34	Zero current detection level	0.0%~300.0%(100.0% corresponds to the rated current of the motor)	5.0%	↗
09-35	Zero current detection delay time	0.01s~600.00s	0.10s	↗
09-36	Output current limit	0.0% (No detection) 0.1%~300.0% (motor rated current)	200.0%	↗
09-37	Output overcurrent detection delay time	0.00s~600.00s	0.00s	↗
09-38	Arbitrary arrival current 1	0.0%~300.0%(motor rated current)	100.0%	↗
09-39	Arbitrary arrival current 1 width	0.0%~300.0%(motor rated current)	0.0%	↗
09-40	Arbitrary arrival current 2	0.0%~300.0%(motor rated current)	100.0%	↗
09-41	Arbitrary arrival current 2 width	0.0%~300.0%(motor rated current)	0.0%	↗
09-42	Timing function selection	0:Invalid 1:Valid	0	
09-43	Timed running time selection	0:09-44 setting 1:AVI1 2:AVI2/ACI 3:Reserved Analog input range corresponds to 09-44	0	
09-44	Timed running time	0.0Min~6500.0Min	0.0Min	
09-45	Lower limit of AVI1 input voltage protection value	0.00V~09-46	3.10V	↗
09-46	Upper limit of AVI1 input voltage protection value	09-45~11.00V	6.80V	↗
09-47	Module temperature reached	0°C~100°C	75°C	↗
09-48	Cooling fan control	0:Fans run during operation 1:The fan keeps running	0	

09 Accessibility parameters

⚡ indicates that the parameters can be set during operation

Parameter	Parameter function	Setting range	Factory setting	
09-49	Wake frequency	Sleep frequency(09-51)~max frequency(00-03)	0.00Hz	⚡
09-50	Wake delay time	0.0s~6500.0s	0.0s	⚡
09-51	Sleep frequency	0.00Hz~Wake frequency(09-49)	0.00Hz	⚡
09-52	Sleep delay time	0.0s~6500.0s	0.0s	⚡
09-53	Arrival time setting for this run	0.0Min~6500.0Min	0.0Min	⚡

11 Fault and protection parameters

⚡ indicates that the parameters can be set during operation

Parameter	Parameter function	Setting range	Factory setting	
11-00	Motor overload protection selection	0:Disabled 1:Enabled	1	⚡
11-01	Motor overload protection gain	0.20~10.00	1.00	⚡
11-02	Motor overload pre-warning coefficient	50%~100%	80%	⚡
11-03	Power-on short circuit protection selection	0:Invalid 1:Valid	1	⚡
11-09	Fault automatic reset times	0~20	0	⚡
11-10	Action selection of fault multi-function output terminal during fault automatic reset	0:No action 1:Action	0	⚡
11-11	Fault automatic reset interval time	0.1s~100.0s	1.0s	⚡
11-12	Input phase loss protection selection	0:Disabled 1:Enabled	1	⚡
11-13	Output phase loss protection selection	0:Disabled 1:Enabled	1	⚡
11-14	First failure type	0:No fault	—	
11-15	Second failure type	1:Short circuit protection (sc)	—	
11-16	Third (last) fault type	2:Overcurrent during acceleration (oc1) 3:Overcurrent during deceleration (oc2) 4:Overcurrent at constant speed (oc3) 5:Overvoltage during acceleration (ou1) 6:Overvoltage during deceleration (ou2) 7:Overvoltage at constant speed (ou3) 8:Reserved 9:Undervoltage (UV) 10:Inverter overload (OL2) 11:Motor overload (ORL1) 12:Input phase loss (SPI) 13:Output phase loss (SPO) 14:Module overheat (oh2) 15:External fault (EF) 16:Communication error (CE) 17:Contactor fault (Cotr) 18:Current detection fault (it) 19:Motor auto-tuning fault (TE) 20:Reserved 21:EEPROM read write error (EEP) 22:Inverter hardware fault (EIU)	—	

11 Fault and protection parameters

↗ indicates that the parameters can be set during operation

Parameter	Parameter function	Setting range	Factory setting	
		23:Motor short circuit to ground (SG) 24:Reserved 25:Reserved 26:Running time arrival(Eond) 27:Reserved 28:Reserved 29:Power-on time arrival(EIND) 30:Load failure (oLL) 31:The PID feedback disconnected (EPID) 40:Wave-by-wave current limiting fault (CbC)		
11-17	Frequency at the third (latest) failure	—	—	
11-18	Current at the third (latest) fault	—	—	
11-19	Bus voltage at the third (latest) fault	—	—	
11-20	Input terminal status at the third (latest) fault	—	—	
11-21	Output terminal status at the third (latest) fault	—	—	
11-22	Inverter status at the third (latest) fault	—	—	
11-23	Power-on time at the third (latest) fault	—	—	
11-24	Running time at the third (latest) failure	—	—	
11-27	Frequency at second failure	—	—	
11-28	Current at second fault	—	—	
11-29	Bus voltage at the second fault	—	—	
11-30	Input terminal status at the second fault	—	—	
11-31	Output terminal status at the second fault	—	—	
11-32	Inverter status at the second fault	—	—	
11-33	Power-on time at the second fault	—	—	
11-34	Running time on second failure	—	—	
11-37	Frequency at first failure	—	—	
11-38	Current at first fault	—	—	
11-39	Bus voltage at first fault	—	—	
11-40	Input terminal status at the first fault	—	—	
11-41	Output terminal status at the first fault	—	—	
11-42	Inverter status at first fault	—	—	
11-43	Power-on time at first failure	—	—	
11-44	Operating time at first failure	—	—	
11-47	Fault protection action selection1	Single digit:Motor overload 0:Coast to stop 1:Stop according to the stop mode	0	↗

11 Fault and protection parameters

⚡ indicates that the parameters can be set during operation

Parameter	Parameter function	Setting range	Factory setting	
		2:Continue to run Tens digital:input phase loss(Same bit) hundreds digital:output phase loss(Same bit) thousands digital:External fault(Same bit) ten thousands digital:Communication error(Same bit)		
11-48	Fault protection action selection 2	Single digit:Reserved Tens digital:EEPROM read write fault 0:Coast to stop 1:Stop according to the stop mode hundreds digital:Reserved thousands digital:Reserved ten thousands digital:Operating time arrival(same as 11-47 digits)	0	⚡
11-49	Fault protection action selection 3	Single digit:Reserved Tens digital:Reserved hundreds digital:Power-on time arrival(same as 11-47 digits) thousands digital:Lost load 0:Coast to stop 1:Stop according to the stop mode 2:Decelerate to 7% of the rated frequency of the motor and continue to run. If the load is not lost, it will automatically return to the set frequency. ten thousands digital:Reserved	0	⚡
11-50	Fault protection action selection 4	Reserved	0	⚡
11-54	Continue running frequency selection in case of failure	0:Run at current operating frequency 1:Run at set frequency 2:Run at upper limit frequency 3:Run at the lower limit frequency 4:Run at abnormal standby frequency	0	⚡
11-55	Abnormal standby frequency	0.0%~100.0%(100.0% corresponds to the maximum frequency 00-03)	100.0%	⚡
11-56	Reserved			
11-57	Reserved			
11-58	Reserved			
11-59	Instantaneous power failure action selection	0:Invalid 1:Deceleration 2:Decelerate to stop	0	⚡
11-60	Instantaneous power failure action pause judgment voltage	80~100.0%	85%	⚡
11-61	Judgment time of instantaneous power failure voltage rise	0.0s~100.0s	0.5s	⚡
11-62	Judgment voltage of instantaneous power failure	60%~100%(Standard bus Voltage)	80%	⚡
11-63	Lost load protection options	0:Invalid 1:Valid	0	⚡
11-64	Lost load detection level	0.0~100.0%	10.0%	⚡
11-65	Lost load detection time	0.0s~60.0s	1.0s	⚡

11 Fault and protection parameters

↗ indicates that the parameters can be set during operation

Parameter	Parameter function	Setting range	Factory setting	
11-67	Over speed detection range	0.0~100.0%	20.0%	
11-68	Over speed detection time	0.001s~6.000s	0.010s	
11-69	Speed deviation detection range	0.0~100.0%	20.0%	
11-70	Speed deviation detection time	0.0s~60.0s	5.0s	

12 Serial communication parameters

↗ indicates that the parameters can be set during operation

Parameter	Parameter function	Setting range	Factory setting	
12-00	Local address	1~247, 0 is broadcast address	1	↗
12-01	Baud rate	Single digit: Modbus 0:300bps 1:600bps 2:1200bps 3:2400bps 4:4800bps 5:9600bps 6:19200bps 7:38400bps 8:57600bps 9:115200bps	0005	↗
12-02	Data format	0:No checking(8-N-1) 1:Even parity checking(8-E-1) 2:Odd parity checking(8-O-1) 3:No checking(8-N-2)	0	↗
12-03	Communication response delay	0ms~20ms	2	↗
12-04	Communication timeout	0.0(invalid), 0.1s~60.0s	0	↗
12-05	Reserved			↗
12-06	Communication reading current resolution	0:0.01A 1:0.1A	0	↗

16 Parameter management

↗ indicates that the parameters can be set during operation

Parameter	Parameter function	Setting range	Factory setting	
16-04	Parameter modification properties	0:Parameters can be read and written 1:The parameter is read-only	0	↗

17 Torque control parameters

↗ indicates that the parameters can be set during operation

Parameter	Parameter function	Setting range	Factory setting	
17-00	Speed/torque control method selection	0:Speed control 1:Torque control	0	
17-01	Torque setting source selection in torque control mode	0:Digital setting1(17-03) 1:AVI1 2:AVI2/ACI 3:Reserved 4:Reserved 5:Communication setting 6:MIN(AVI1,AVI2/ACI) 7:MAX(AVI1,AVI2/ACI)(1-7 option full scale, corresponding to 17-03 digital setting)	0	
17-03	Torque digital setting in torque control mode	-200.0%~200.0%	150.0%	↗

17 Torque control parameters

↗ indicates that the parameters can be set during operation

Parameter	Parameter function	Setting range	Factory setting	
17-05	Torque control forward maximum frequency	0.00Hz~Max frequency	50.00Hz	↗
17-06	Torque control reverse maximum frequency	0.00Hz~Max frequency	50.00Hz	↗
17-07	Torque control acceleration time	0.00s~65000s	0.00s	↗
17-08	Torque control Deceleration time	0.00s~65000s	0.00s	↗

22 Control optimization parameters

↗ indicates that the parameters can be set during operation

Parameter	Parameter function	Setting range	Factory setting	
22-00	DPWM switching upper limit frequency	5.00Hz~Maximum operating frequency	8.00Hz	↗
22-01	Reserved			↗
22-02	Dead zone compensation mode selection	0:No compensation 1:Compensation mode 1	1	↗
22-03	Random PWM depth	0:Random PWM is invalid 1~10:Random depth of PWM carrier frequency	0	↗
22-04	Fast current limit enable	0:No enabling 1:Enabling	1	↗
22-05	Current detection compensation	100~120	110	↗
22-06	Undervoltage level	DC200V-DC420V	220V:200V 380V:350V	↗
22-07	Reserved			
22-08	Reserved			
22-09	Overvoltage level	DC200V-DC820V	220V:400V 380V:820V	

24 Auxiliary function parameters 1

↗ indicates that the parameters can be set during operation

Parameter	Parameter function	Setting range	Factory setting	
24-04	S curve start time ratio 2	0.0%~(100.0%-22-05)	30.0%	↗
24-05	S curve end time ratio 2	0.0%~(100.0%-22-04)	30.0%	↗
24-06	S curve start time ratio 3	0.0%~(100.0%-22-07)	30.0%	↗
24-07	S curve end time ratio 3	0.0%~(100.0%-22-06)	30.0%	↗
24-08	S curve start time ratio 4	0.0%~(100.0%-22-09)	30.0%	↗
24-09	S curve end time ratio 4	0.0%~(100.0%-22-08)	30.0%	↗

26 Specific parameters

↗ indicates that the parameters can be set during operation

Parameter	Parameter function	Setting range	Factory value	
26-00	Pre-torque coefficient 1	0.0%~150.0%	0.0%	
26-01	Pre-torque bias	0.0%~100.0%	0.0%	
26-02	Zero speed KP at shutdown	1~100	10	
26-03	Zero speed TI at shutdown	0.01s~10.00s	0.50s	

26 Specific parameters

↗ indicates that the parameters can be set during operation

Parameter	Parameter function	Setting range	Factory value	
26-08	Pre-torque reduction coefficient	0~100	0	
26-09	Pre-torque enhancement coefficient	0~200	0	
26-12	FWD section speed 0 deceleration time compensation	0.0s~600.0s	0.0s	
26-13	REV section speed 0 deceleration time compensation	0.0s~600.0s	0.0s	
26-14	Contactor feedback detection time	0.00s~60.00s	2.00s	
26-15	Contactor feedback detection selection	0:No detection 1:Detection	0	
26-16	Brake feedback detection time	0.00s~60.00s	2.00s	
26-17	Brake feedback detection selection	0:No detection 1:Detection	0	
26-18	Output delay	0.00s~60.00s	0.10s	
26-19	Opening brake delay	0.00s~60.00s	0.10s	
26-20	Start delay	0.00s~60.00s	0.10s	
26-21	Shutdown and closing brake frequency	0.00Hz~Max.frequency (00-03)	0.00Hz	
26-22	Closing brake delay	0.00s~60.00s	0.10s	
26-23	Shutdown delay	0.00s~60.00s	0.10s	
26-24	Contactor turn off delay	0.00s~60.00s	0.10s	
26-25	Pre-torque selection	0: Close 5: No weighing start-up compensation	0	
26-26	Pre-torque coefficient	0.0%~150.0%	0.0%	
26-27	Special function selection	Units:Reserved Ten:Start Compensation Method 0: Up and down mode compensation 1: Positive and negative torque compensation method Hundred:pulse start 0: AB pulse 1: AB phase Thousands:Strengthening Methods 0: OFF 1: ON	H.0000	

99 Monitoring parameters

✎ indicates that the parameters can be set during operation

Parameter	Parameter function	Setting range
99-00	Running frequency(Hz)	0.01Hz
99-01	Setting frequency(Hz)	0.01Hz
99-02	Bus voltage(V)	0.1V
99-03	Output voltage(V)	1V
99-04	Output current(A)	0.01A
99-05	Output power(kW)	0.1kW
99-06	Output torque(%)	0.1%
99-07	MI input status	1
99-08	MO output status	1
99-09	AVI1 voltage(V)	0.01V
99-10	AVI2/ACI voltage(V)	0.01V
99-14	Load speed	1
99-19	Feedback speed(Unit 0.1Hz)	0.1Hz
99-20	Remaining running time	0.1Min
99-21	AVI1 voltage before calibration	0.001V
99-22	AVI2/ACI voltage before calibration	0.001V
99-25	Current power-on time	1Min
99-26	Current running time	0.1Min
99-28	Communication setting value	0.01%
99-29	Encoder feedback frequency	0.01Hz
99-30	Main frequency X display	0.01Hz
99-31	Auxiliary frequency Y display	0.01Hz
99-32	View any memory address value	1
99-38	Encoder AB pulse	1
99-39	V/f separation target voltage	1V
99-40	V/f separation output voltage	1V
99-41	Visual display of MI input status	1
99-42	Visual display of MO input status	1
99-43	MI function status visual display 1(function 01- function 40)	1
99-44	MI function status visual display 2(function 41- function 50)	1
99-61	Inverter status	1
99-62	Fault code	1
99-63	Number of AB pulses during the 0-speed startup phase	1
99-64	Sine and Cosine CD difference	1
99-78	Start the 0-speed phase movement of the AB phase cumulative value	1
99-88	Elevator operating status	1

5 DESCRIPTION OF FUNCTIONAL PARAMETERS

This chapter will give a detailed description of all functional parameters. It is divided into various parameter groups according to the attributes of the parameters; making parameter setting easier. In most applications, users can complete the settings before operation according to the related parameter settings in the parameter group.

The parameter groups are as follows

Parameter	Function	Parameter	Function	Parameter	Function
00	Basic function parameters	06	Output terminal parameters	17	Torque control parameters
01	Motor control parameters	07	Start and stop control parameters	22	Control optimization parameters
02	Vector control parameters	08	Man-machine interface parameters	24	Auxiliary function parameters 1
03	V/f control parameters	09	Accessibility parameters	26	Specific parameters
04	Input terminal parameters	11	Fault and protection parameters	99	Monitoring parameters
05	Multi-speed	12	Serial communication parameters		

↗ Indicates that the parameters can be set during operation

00 Basic Functions Parameters

00-00	Command source selection		↗	Factory setting	0
	Setting range	0	Keyboard command (LED off)		
		1	Terminal command (LED on)		
		2	Communication command (LED flicker)		
		3	Elevator specific (contactor+brake output)		

Select the input channel for inverter control commands.

Inverter control commands include: start, stop, forward, reverse, and jog.

0: Keyboard command channel ("LOC/REM" indicator off)

Run command control is performed by the RUN, STOP/RESET buttons on the operation panel.

1: Terminal command channel ("LOC/REM" indicator on)

Run command control is performed by multi-function input terminals FWD, REV, FJOG, RJOG, etc.

2: Communication command channel ("LOC/REM" indicator flicker)

The running command is given by the host computer through communication.

3: Elevator specific (contactor+brake output):

It is controlled by the multifunctional input terminals FWD and REV, combined with the contactor and brake control timing, for operation command control.

00-01	Keyboard and terminal UP/DOWN setting selection		↗	Factory setting	2
	Setting range	0	Stop memory and power failure storage		
		1	Stop memory		
		2	Stop no memory		

This function is only valid when the frequency source is set digitally.

"Stop memory" refers to the inverter is stopped, a digital frequency keep the last set frequency retention time, keyboard ▲, ▼ key or the UP terminal, the frequency correction for maintaining effective DOWN, and again after power down Still effective.

"Stop memory" means that after the inverter is stopped, the digital set frequency is retained as the set frequency at the last stop time, and the frequency correction by the keyboard ▲, ▼ keys or terminals UP and DOWN remains valid.

"Stop no memory" means that after the inverter stops, the digital set frequency value returns to the value of 00-06 (keyboard given frequency), and the frequency correction performed by the keyboard ▲, ▼ keys or terminals UP and DOWN is cleared.

00-02	Main frequency source X selection		Factory setting	1
Setting range	0	Digital setting (keyboard given frequency 00-06, UP/DOWN can be modified)		
	1	AVI1		
	2	AVI2/ACI		
	3	Reserved		
	4	Multi-speed command		
	5	Reserved		
	6	Communication setting		
	7	Reserved		
	8	Panel potentiometer		
	9	Reserved		
	10	Elevator specific multi-stage speed		

Select the input channel of the main given frequency of the inverter:

0: Digital setting

The initial value of the set frequency is 00-06 "Keyboard given frequency" value. The set frequency value of the inverter can be changed by the ▲ and ▼ keys of the keyboard (or UP and DOWN of the multi-function input terminal).

Tip: Please refer to parameter 00-01 for UP and DOWN.

1: AVI1

2: AVI2/ACI

The frequency is determined by the analog input terminal. The control board provides 2 analog input terminals (AVI1, AVI2/ACI).

Among them, AVI1 is 0V ~ 10V voltage type input, AVI2/ACI can be 0V ~ 10V voltage input, can also be 4mA ~ 20mA current input, selected by the jumper on the control board.

The corresponding relationship between the input voltage value of AVI1, AVI2/ACI and the target frequency can be freely selected by the user.

4: Multi-speed command

When this frequency setting mode is selected, the inverter runs in multi-speed mode. Group 04 and Group 05 "multi-stage speed control group" parameters need to be set to determine the correspondence between a given percentage and a given frequency, the multi-step speed command will take precedence over other frequency reference methods.

6: Communication setting

The frequency command is given by the host computer through communication. For details, please refer to 12 Communication protocol.

8: Panel potentiometer

The main frequency source is given by the rotation of the potentiometer on the panel.

10: Elevator specific multi-stage speed

By combining multiple speed commands with contactor and brake control timing, the segment speed is given.

00-03	Maximum frequency		Factory setting	50.00 Hz
	Setting range	50.00Hz~500.00Hz		

Used to set the maximum output frequency of the inverter. Frequency commands are all scaled according to this parameter, which is the basis of frequency setting.

The maximum output frequency of S3100L can reach 3200Hz. The frequency command resolution and frequency input range can be changed by selecting the number of decimal places of frequency command through 00-25. When 00-25 is 1, the frequency resolution is 0.1Hz, and the setting range of 00-03 is 50.0Hz~3200.0Hz;

00-04	Upper limit frequency	↗	Factory setting	50.00Hz
	Setting range	Lower limit frequency 00-05~max frequency 00-03		

When the upper limit frequency is set by analog , 00-21 is used as the offset value of the set value, and the offset frequency is 00-20.

The set upper limit frequency value is superimposed as the final upper limit frequency setting value.

00-05	Lower limit frequency	↗	Factory setting	0.00Hz
	Setting range	0.00Hz~Upper limit frequency 00-04		

When the frequency command is lower than the lower limit frequency set by 00-05, the inverter can be stopped, run at the lower limit frequency or run at zero speed, and set the operation mode through 09-14 (the set frequency is lower than the lower limit frequency operation mode).

00-06	Keyboard setting frequency	↗	Factory setting	50.00Hz
	Setting range	0.00~max frequency 00-03		

When the frequency source is selected as "digital setting", the parameter value is the initial value of the frequency digital setting of the inverter.

00-07	Acceleration time1	↗	Factory setting	Type setting
	Setting range	0.00s~65000s		

00-08	Deceleration time 1	↗	Factory setting	Type setting
	Setting range	0.00s~65000s		

The acceleration time refers to the time required for the inverter to accelerate from zero frequency to the acceleration and deceleration base frequency (determined from 00-23), see t1 in Figure 5-1.

The deceleration time refers to the time required for the inverter to decelerate to the zero frequency from the base frequency of acceleration and deceleration (determined from 00-23), see t2 in Figure 5-1

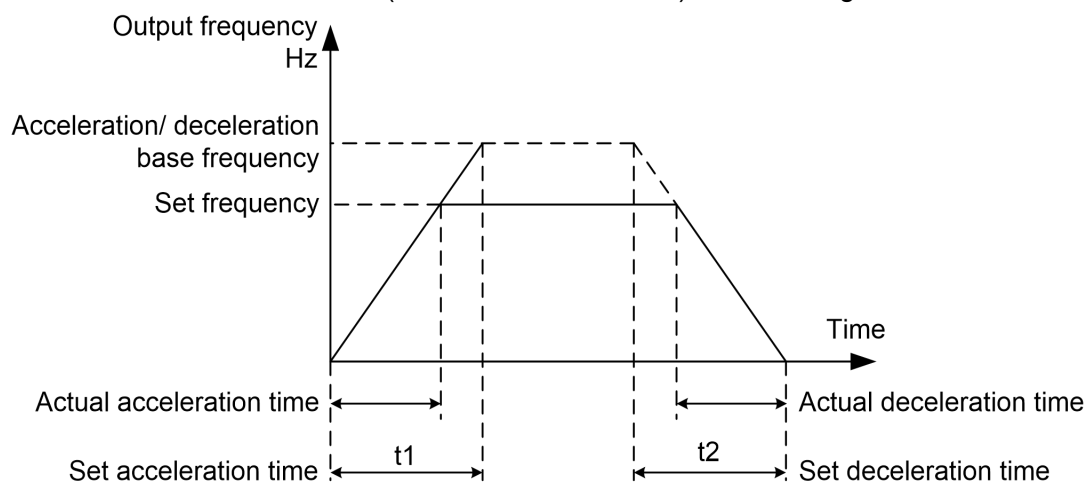

Figure 5-1 Schematic diagram of acceleration and deceleration time

S3100L provides 4 groups of acceleration and deceleration time, users can use the digital input terminal MI to switch selection, the four groups of acceleration and deceleration time are set by the following parameters:

The first group: 00-07, 00-08; The second group: 09-03, 09-04; The third group: 09-05, 09-06; The fourth group: 09-07, 09-08.

00-09	Operation direction		↗	Factory setting	0
	Setting range	0	Reverse		
		1	Forward		

Used to change the direction of the motor, its role is equivalent to changing the direction of motor rotation by adjusting any two motor lines.

Note: After the parameters are initialized, the motor running direction will return to its original state. For occasions where it is strictly forbidden to change the direction of the motor after system debugging, please use it with caution.

00-10	Carrier frequency		↗	Factory setting	Type setting
	Setting range	0.5kHz~16.0kHz			

This function adjusts the carrier frequency of the inverter. By adjusting the carrier frequency can reduce the motor noise, avoid the resonance point of the mechanical system, reduce the line leakage current to the ground and reduce the interference generated by the inverter.

The advantages of high carrier frequency: the current waveform is ideal, the current harmonics are less, and the motor noise is small;

Disadvantages of high carrier frequency: increased switching loss, increased temperature rise of the inverter, and affected the output capacity of the inverter. Under high carrier frequency, the inverter needs to be derated; at the same time, the leakage current of the inverter increases, which increased electromagnetic interference.

The effect of carrier frequency on the following performance:

Carrier frequency	Low	→	High
Motor noise	Large	→	Small
Output current waveform	Bad	→	Good
Motor temperature rise	High	→	Low
Inverter temperature rise	Low	→	High
Leakage current	Small	→	Large
External radiation interference	Small	→	Large

The factory setting of carrier frequency is different according to different power models. The user can modify it as needed, but it should be noted that if the carrier frequency is set higher than the factory value, it will cause the temperature rise of the inverter radiator to increase. At this time, the user needs to derate the inverter, otherwise the inverter will be in danger of overheating.

00-11	Parameter initialization		↗	Factory setting	0
	Setting range	0	No operation		
		1	Restore factory parameters, excluding motor parameters		
		2	Clear record information		

1. Restore the factory settings, most of the inverter parameters are restored to the factory values, but the motor parameters, frequency command decimal point (00-25), fault record information, cumulative running time (08-11), cumulative power-on time (08-13), the cumulative power consumption (08-14) does not recover.

2. Clear record information

Clear the inverter fault record information, cumulative running time (08-11), cumulative power-on time (08-13), cumulative power consumption (08-14).

Note: The parameter value automatically returns to 0 after the operation is completed.

00-12	Carrier frequency adjusts with temperature		↗	Factory setting	1
	Setting range	0	no		
		1	yes		

The carrier frequency is adjusted with the temperature. When the inverter detects that the radiator temperature is high, the carrier frequency is automatically reduced to prevent the inverter temperature from rising too high and reduce the overheating alarm. When the temperature of the radiator drops, the carrier frequency automatically returns to the set value.

00-14	Auxiliary frequency source Y selection (Refer to 00-02)		Factory setting	0
	Setting range	0	Digital setting (keyboard given frequency 00-06, UP /DOWN can be modified)	
		1	AVI1	
		2	AVI2/ACI	
		3	Reserved	
		4	Multi-speed command	
		5	Reserved	
		6	Communication setting	
		7	Reserved	
		8	Panel potentiometer	
		9	Reserved	

When the auxiliary frequency source is used independently as the frequency reference channel (that is, the frequency source selection is switched to Y), the method of use is the same as the main frequency source X. You can refer to the 00-02 instructions.

When the auxiliary frequency source is given as a superposition (that is, the frequency source is selected as X+Y, X to X+Y switching or Y to X+Y switching), please note:

(1) When the auxiliary frequency source selects the digital setting, the given frequency (00-06) of the keyboard does not work, and the frequency can be adjusted by the ▲ and ▼ keys of the keyboard (or UP and DOWN of the multi-function input terminal). The frequency is adjusted on the basis of the main frequency.

(2) When the auxiliary frequency source selects analog (AVI1, AVI2/ACI) as the timing, the input setting 100% corresponds to the frequency range, which can be set by 00-15 and 00-16.

Note: The setting values of 00-02 and 00-14 cannot be the same, that is, the auxiliary frequency source Y and the main frequency source X cannot select the same channel, otherwise the operation may be messy.

00-15	Selection of auxiliary frequency source Y range during stacking		↗	Factory setting	0
	Setting range	0	Relative to the maximum frequency		
		1	Relative to the main frequency source X		
00-16	Auxiliary frequency source Y range when superimposed		↗	Factory setting	100%
	Setting range	0%~150%			

When the frequency source is selected as "frequency superposition" (that is, 00-17 is set to 1, 3 or 4), these two parameters are used to determine the adjustment range of the auxiliary frequency source.

00-15 if you select 1 relative to the main frequency source X, the range of the auxiliary frequency source will change with the change of the main frequency X.

00-17	Frequency source overlay selection		↗	Factory setting	0
	Setting range	Single digit	Frequency source selection		
		0	Main frequency source X		
		1	Main and auxiliary calculation results (the operation relationship is determined by ten digits)		
		2	Switch between main frequency source X and auxiliary frequency source Y		
		3	Switch between main frequency source X and main and auxiliary calculation results		
		4	Switch between auxiliary frequency source Y and main and auxiliary calculation results		

00-17	Frequency source overlay selection		↗	Factory setting	0
		Tens digit	Frequency source main and auxiliary operation relationship		
		0	Main+auxiliary		
		1	Main-auxiliary		
		2	Maximum of both		
		3	Minimum of both		

Use this parameter to select the frequency reference channel. The frequency setting is realized by the combination of the main frequency source X and the auxiliary frequency source Y.

Single digit: frequency source selection:

0: Main frequency source X

The main frequency X is taken as the target frequency.

1: Main and auxiliary calculation results The main and auxiliary calculation results are used as the target frequency. For the relationship between the main and auxiliary calculations, please refer to the description of "Ten" of this parameter.

2: Switch between main frequency source X and auxiliary frequency source Y When multi-function input terminal function 18 (frequency switching) is invalid, main frequency X is used as the target frequency.

When the multi-function input terminal function 18 (frequency source switching) is valid, the auxiliary frequency Y is used as the target frequency.

3: Switch between main frequency source X and main and auxiliary calculation results When multi-function input terminal function 18 (frequency switching) is invalid, main frequency X is used as the target frequency. When the multi-function input terminal function 18 (frequency switching) is valid, the main and auxiliary calculation results are used as the target frequency.

4: Switch between auxiliary frequency source Y and main and auxiliary calculation results When multi-function input terminal function 18 (frequency switching) is invalid, auxiliary frequency Y is used as the target frequency. When the multi-function input terminal function 18 (frequency switching) is valid, the main and auxiliary calculation results are used as the target frequency.

Tens: Main and auxiliary calculation relationship of frequency source:

0: Main frequency source X + auxiliary frequency source Y

The sum of the main frequency X and the auxiliary frequency Y is taken as the target frequency. Realize the given function of frequency superposition.

1: Main frequency source X- auxiliary frequency source Y

The difference between the main frequency X and the auxiliary frequency Y is taken as the target frequency.

2: MAX (main frequency source X, auxiliary frequency source Y) Take the maximum absolute value of the main frequency X and auxiliary frequency Y as the target frequency.

3: MIN (main frequency source X, auxiliary frequency source Y) Take the minimum absolute value of the main frequency X and auxiliary frequency Y as the target frequency. In addition, when the frequency source is selected as the main and auxiliary operations, the offset frequency can be set through 00-19, and the offset frequency is superimposed on the main and auxiliary operation results to flexibly respond to various needs.

00-19	Auxiliary frequency source offset frequency when superimposed		↗	Factory setting	0.00Hz
	Setting range	0.00Hz~max frequency 00-03			

This parameter is only valid when the frequency source is selected as the main and auxiliary operation.

When the frequency source is the main and auxiliary operation, 00-19 is used as the offset frequency, and the result of the main and auxiliary operation is superimposed as the final frequency setting value, and the frequency setting is more flexible.

00-20	Upper frequency source		Factory setting	0
	Setting range	0	00-04 setting	
		1	AVI1	
		2	AVI2/ACI	
		3	Reserved	

00-20	Upper frequency source		Factory setting	0
		4	Reserved	
		5	Communication setting	

Source selection for upper frequency. Especially in torque control, the output frequency of the inverter can be changed by changing the upper limit frequency.

Note: 100% of the analog input setting corresponds to 00-04.

00-21	Upper frequency offset		↗	Factory setting	0.00Hz
	Setting range	0.00Hz~max frequency 00-03			

When the upper limit frequency is set by analog or PULSE, 00-21 is used as the offset value of the set value, and the offset frequency is superimposed on the set upper limit frequency value of 00-20 as the final set value of the upper limit frequency.

00-22	Acceleration and deceleration time unit		Factory setting	1
	Setting range	0	1s	
		1	0.1s	
		2	0.01s	

S3100L has 3 kinds of acceleration and deceleration time unit selection. When modified, the decimal points of the 4 groups of acceleration and deceleration time will change, and the corresponding acceleration and deceleration time will also change. In application, pay attention to the specific value of acceleration and deceleration time.

00-23	Base frequency of acceleration and deceleration time		Factory setting	0
	Setting range	0	Maximum frequency (00-03)	
		1	Set frequency	
		2	100Hz	

The acceleration and deceleration time refers to the acceleration and deceleration time from zero frequency to the frequency set by 00-23. Figure 5-1 is the schematic diagram of acceleration and deceleration time.

When 00-23 is selected as 1, if the set frequency changes frequently, the acceleration of the motor will also follow the change, so you need to pay attention to it during application.

00-24	Base frequency for UP/DOWN command during running		Factory setting	1
	Setting range	0	Running frequency	
		1	Set frequency	

This parameter is valid only when the frequency source is digitally set.

When the ▲, ▼ keys on the keyboard or the terminal UP/DOWN change the frequency, select whether to increase or decrease based on the running frequency or increase or decrease based on the set frequency.

Note that when 0 is selected, when the inverter is increasing or decreasing when the inverter is in the process of acceleration and deceleration, the given frequency may change significantly.

00-25	Frequency command resolution		Factory setting	2
	Setting range	1	0.1Hz	
		2	0.01Hz	

This parameter is used to determine the number of decimal points for all frequencies, and the frequency resolution also changes accordingly.

When the frequency resolution is 0.1Hz, the maximum output frequency of S3100L can reach 3200.0Hz.

01 Motor Control Parameters

01-00	The first motor control mode		Factory setting	0
	Setting range	0	Speed sensorless vector control (SVC)	
		1	Vector control with speed sensor	
		2	Vf control	

0: Speed sensorless vector control

Refers to vector control, which is suitable for the usual high-performance control occasions. One inverter can only drive one motor. Such as machine tools, centrifuges, wire drawing machines, injection molding machines and other loads.

2: V/f control Applicable to the occasions where the load requirement is not high, or one inverter drives multiple motors, such as fans and pumps. It can be used in a situation where one inverter drives multiple motors.

Tip: Motor vector parameter self-learning must be done when selecting vector control mode. Only accurate motor parameters can take advantage of the vector control method. By adjusting the speed regulator parameter 02 group of parameters, you can get better performance.

1: Vector Control with Speed Sensor (FVC)

Refers to encoder closed-loop vector control, suitable for dedicated high-performance control scenarios, such as elevator applications, where one frequency converter can only drive one motor.

01-01	Motor parameter self-learning		Factory setting	0
	Setting range	0	No self-learning	
		11	Synchronous motor static self-learning	
		12	Synchronous motor complete self-learning	

0: No self-learning

11: Synchronous motor static auto-learning

When the synchronous motor can not be separated from the load, the synchronous motor with load auto-learning has to be selected. In this process, the motor does not run.

Before the auto-learning of synchronous motor with belt, it is necessary to set motor type and motor name plate parameter 01-02-01-06 correctly.

The synchronous motor is equipped with auto-learning, and the frequency converter can obtain the initial position angle of the synchronous motor. At this time, it is necessary for the synchronous motor to operate normally. Therefore, the auto-learning must be carried out before the synchronous motor is installed and used for the first time.

Action description: set the function code to 11, and then press the run key, the frequency converter will carry out on load auto-learning.

12: Synchronous motor complete auto-learning

If the motor can be separated from the load, it is recommended to select the no-load auto-learning of synchronous motor, which can obtain better performance than the synchronous motor with load auto-learning.

In the process of no-load auto-learning, the inverter completes the on-load auto-learning first, then accelerates to 00-06 according to the acceleration time 00-07, and then stops the machine according to the deceleration time 00-07 and ends the auto-learning. Note that 00-06 must be set to a value other than 0, otherwise identification can not be carried out normally.

Before no-load auto-learning of synchronous motor, in addition to setting motor type and motor nameplate parameters 01-02 ~ 01-06, it is also necessary to set encoder pulse number 01-27, encoder type 01-28, encoder pole pairs 01-34 and 01-35.

Action description: set the function code to 11, and then press the run key, the frequency converter will carry out no-load auto-learning.

Note: self learning can only be carried out in keyboard operation mode, and motor auto-learning cannot be carried out in terminal operation and communication operation mode.

01-02	Motor rated power		Factory setting	Type setting
	Setting range	0.1kW~1000.0kW		

01-03	Motor rated frequency	Factory setting	Type setting
	Setting range	0.01Hz~max frequency	
01-04	Motor rated rotation speed	Factory setting	Type setting
	Setting range	1rpm~65535rpm	
01-05	Motor rated voltage	Factory setting	Type setting
	Setting range	1V~2000V	
01-06	Motor rated current	Factory setting	Type setting
	Setting range	0.01A~655.35A(Inverter power <=55kW) 0.1A~6553.5A(Inverter power >55kW)	

Note: The above are the motor nameplate parameters, regardless of V/f control or vector control, the relevant parameters need to be set accurately according to the motor nameplate.

In order to obtain better V/f or vector control performance, motor parameter self-learning is required. Accurate parameter self-learning comes from the correct input of motor nameplate parameters.

01-12	Motor type selection	Factory setting	2
	Setting range	2	Permanent magnet synchronous motor

01-13	Learning instruction for sine cosine encoder	Factory setting	0
	Setting range	1	Static learning

When selecting the closed-loop vector (01-00:1FVC) mode of the sine cosine encoder type (01-28 is 1), this parameter 01-13 needs to be set to 1 to start static self-learning.

01-16	Stator resistance of synchronous motor	Factory setting	Type setting
	Setting range	0.001Ω~65.535Ω(Inverter power<=55kW) 0.0001Ω~6.5535Ω(Inverter power >55kW)	
01-17	D-axis inductance of synchronous motor	Factory setting	Type setting
	Setting range	0.01mH~655.35mH(Inverter power <=55kW) 0.001mH~65.535mH(Inverter power >55kW)	
01-18	Q axis inductance of synchronous motor	Factory setting	Type setting
	Setting range	0.01mH~655.35mH(Inverter power <=55kW) 0.001mH~65.535mH(Inverter power >55kW)	
01-20	Back-EMF coefficient of synchronous motor	Factory setting	Type setting
	Setting range	0.1V~6553.5V	

01-16~01-20 are the parameters of the synchronous motor. These parameters are generally not on the nameplate of the motor, and need to be obtained through the inverter self-learning.

Among them, "synchronous motor on-load learning" can only obtain three parameters 01-16~01-18, while "synchronous motor no-load learning" can obtain these four parameters.

If the synchronous motor cannot be learned on site, you can enter the above corresponding parameter values according to the parameters provided by the motor manufacturer.

01-27	Encoder pulse number	Factory setting	2048
	Setting range	1~65535	
01-28	Encoder type	Factory setting	1
	Setting range	0:Reserved	1:Sine cosine
01-30	Encoder phase sequence	Factory setting	0
	Setting range	0:Forward sequence	1:Reverse sequence
01-31	Encoder installation angle	Factory setting	0.0
	Setting range	0.0~359.9	

01-32	Sine and Cosine CD Direction		Factory setting	0
	Setting range	0:Forward sequence 1:Reverse sequence		

To configure the encoder, set the actual encoder type and pulse precision to parameters 01-27 and 01-28, and the rotation direction to 01-30. The installation angle can be determined after auto-tuning (01-31). For sine/cosine encoders, additionally set the CD direction (01-32).

In elevator applications, motor parameter calibration and encoder orientation learning typically are required to perform under static conditions. Therefore, encoder orientation confirmation must be performed during motor operation in open-loop vector mode. After completing static parameter learning in this mode, set 64-00 to 1 to activate encoder monitoring in open-loop vector mode. Run the motor in the specified forward direction at a set frequency, then verify the encoder feedback frequency (01-27 affects) and direction (01-30 switchable) displayed on 99-29. If the feedback matches the set frequency, the parameters are validated. Subsequently, proceed with closed-loop parameter learning using the encoder.

For the positive-cosine encoder, set 24-02 to H.0001. Then operate the elevator and check the value of 99-64 to confirm whether it is in the same direction as 99-29(both positive or negative) , If it is in different directions, set 01-32 to align the values of 99-64 and 99-29.

02 Vector Control Parameters

02 Group parameters are only valid for vector control, not for V/f control.

02-00	Speed loop proportional gain 1	↗	Factory setting	20
	Setting range	1~100		
02-01	Speed loop integration time 1	↗	Factory setting	0.50s
	Setting range	0.01s~10.00s		
02-02	Switching frequency 1	↗	Factory setting	5.00Hz
	Setting range	0.00~02-05		
02-03	Speed loop proportional gain 2	↗	Factory setting	20
	Setting range	0~100		
02-04	Speed loop integration time 2	↗	Factory setting	1.00s
	Setting range	0.01s~10.00s		
02-05	Switching frequency 2	↗	Factory setting	10.00Hz
	Setting range	02-02~max frequency		

When the inverter runs at different frequencies, you can select different speed loop PI parameters. Below the switching frequency 1 (02-02), the speed loop PI parameters are: 02-00 and 02-01. Above the switching frequency 2 (02-05), the speed loop PI parameters are: 02-03 and 02-04. Between the two, the PI parameters are obtained from the linear changes of the two sets of parameters, as shown in Figure 5-2:

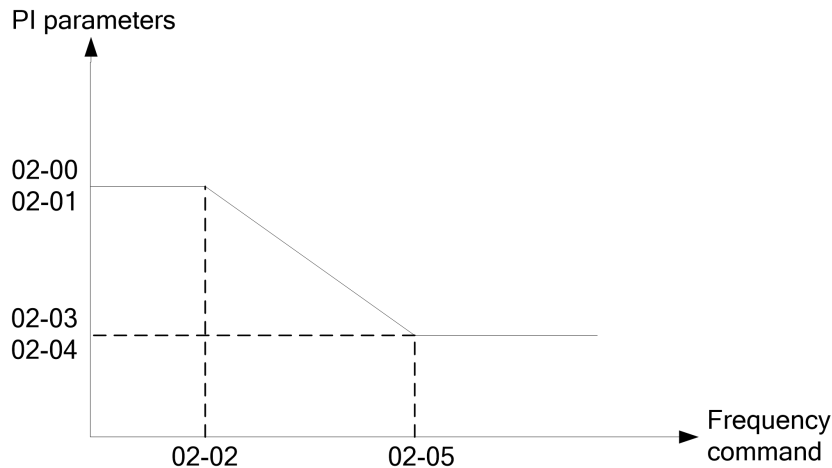

Figure 5-2 Schematic diagram of PI parameter

By setting the proportional coefficient and integral time of the speed regulator, the dynamic response characteristics of the speed loop of vector control can be adjusted. Increasing the proportional gain and reducing the integration time can speed up the dynamic response of the speed loop. However, if the proportional gain is too large or the integration time is too small, it is easy to cause system oscillation and overshoot. If the proportional gain is too small, it may easily lead to steady-state oscillation of the system, and there may be a static speed difference.

The PI parameters of the speed loop are closely related to the inertia of the system. For different load characteristics, the default PI parameters need to be adjusted to meet the needs of various occasions.

02-06	Vector control slip gain	↗	Factory setting	100%
	Setting range	50%~200%		

For speed sensorless vector control, this parameter is used to adjust the speed stability accuracy of the motor: when the motor is loaded with a low speed, increase this parameter, and vice versa.

02-07	Digital setting of torque upper limit in speed control mode	↗	Factory setting	150.0%
	Setting range	0.0%~200.0%		

In speed control mode, the maximum value of the inverter's output torque is selected by the upper torque source 02-10. When the analog, PULSE pulse, and communication settings are selected, the corresponding set 100% corresponds to 02-07, 100% is the rated torque of the inverter.

02-08	Speed loop filter time constant	↗	Factory setting	28
	Setting range	0~31		

In vector control mode, this parameter is used to filter the speed loop torque command. This parameter generally does not need to be adjusted. When the speed fluctuation is large, the filtering time can be increased appropriately; if the motor oscillates, the parameter should be appropriately reduced. The speed loop filter time constant is small, the output torque of the inverter may fluctuate greatly, but the speed response is fast.

02-09	Vector control over excitation gain	↗	Factory setting	64
	Setting range	0~200		

During deceleration of the inverter, overexcitation control can suppress the rise of bus voltage and avoid overvoltage faults. The greater the overexcitation gain, the stronger the suppression effect.

However, if the gain is too large, it is easy to cause the output current to increase, which needs to be set appropriately. For the occasions with small inertia and braking resistance, it is recommended to set the gain to 0.

02-10	Torque upper limit source in speed control mode	↗	Factory setting	0
	Setting range	0	Parameter setting	
		1	AVI1	
		2	AVI2/ACI	
		3	reserved	
		4	reserved	
		5	Communication setting	
		6	MIN(AVI1,AVI2/ACI)	
		7	MAX(AVI1,AVI2/ACI)	
	The full scale of the 1-7 option corresponds to 02-07			

In speed control mode, this parameter is used to select the torque upper limit source of the inverter.

02-13	Excitation adjustment proportional gain	↗	Factory setting	3000
	Setting range	0~60000		
02-14	Excitation adjustment integral gain	↗	Factory setting	500
	Setting range	0~60000		

02-15	Torque adjustment proportional gain		↗	Factory setting	3000
	Setting range	0~60000			
02-16	Torque adjustment integral gain		↗	Factory setting	500
	Setting range	0~60000			

The vector control PI adjusts the parameter. This parameter is automatically obtained after the asynchronous motor completes self-learning, and generally does not need to be modified.

02-18	Field weakening mode of synchronous motor		↗	Factory setting	1
	Setting range	0	Not weak magnetic		
		1	Automatic adjustment mode		
		2	Calculation + automatic adjustment comprehensive mode		
02-19	Field weakening gain of synchronous motor		↗	Factory setting	5
	Setting range	0~50			
02-23	Output voltage upper limit margin of synchronous motor		↗	Factory setting	5%
	Setting range	0%~50%			

This group of parameters is used for field weakening control of the synchronous motor.

(1) 02-18=0 not weak magnetic

The synchronous motor does not perform field weakening control. At this time, the maximum value of the motor speed can be related to the inverter bus voltage. The advantage is that there is no field weakening current and the output current is small. The disadvantage is that the operating frequency cannot reach the set frequency. Higher speeds need to turn on the field weakening function.

(2) 02-18=1 automatic adjustment mode

This field weakening method is simple and reliable. The higher the speed, the larger the field weakening current. When the rated current of the motor is reached, it is not allowed to increase the speed, otherwise it will report an overload after a long time of operation. Weak magnetic coefficient 02-19, but excessive 02-19 will cause current instability.

(3) 02-18=2 calculation + automatic adjustment comprehensive mode

The speed of weak field current adjustment of the calculation + automatic adjustment synthesis method is relatively fast. It can be set to this mode when the automatic adjustment cannot meet the requirements. However, this mode depends on the motor parameter values, and its stability is not as good as Mode 1.

After entering the field weakening, if the output voltage is expected to be higher, so that the field weakening current is smaller, the output voltage saturation margin of the synchronous motor can be appropriately reduced 02-23, but too small 02-23 will make the output voltage more easily saturated and affect the control performance.

02-22	The upper limit of generating torque becomes effective			Factory setting	0
	Setting range	0	OFF		
		1	ON		

When 02-22 is set to 1, the upper limit of power generation torque 02-12 and the upper limit of power generation torque 02-11 are effective. By default, there is no distinction between power generation and electric torque, and the upper limit is 22-07

02-24	Initial position angle detection current of synchronous motor		↗	Factory setting	80%
	Setting range	10%~180%			
02-25	Initial position angle detection of synchronous motor		↗	Factory setting	0
	Setting range	0	Check every run		
		1	Not check		
		2	Power-on first run detection		

The initial position angle detection is generally used for SVC. Its advantage is that it will not reverse when starting, but the disadvantage is that there is a certain noise. For the occasions where reverse rotation is not allowed at startup and the position of the motor rotor will change after stopping 02-25 Must be set to 0, otherwise it can be

set to 1 or 2.

You can set the detected current value through 02-24. The smaller the current is, the smaller the sound will be during detection, but too small may cause inaccurate position detection.

02-26	Speed mode		Factory setting	0
	Setting range	0	Mode 0	
		1	Mode 1	

When speed mode 0 is selected, the speed loop PI parameter uses a two-stage PI parameter group of 02-00 to 02-05. When speed mode 1 is selected and 02-43 is set to 1 to Servo ON 0-speed PI, the speed loop PI parameters use a three-segment PI parameter group of 02-00 to 02-05 and 02-44 to 02-46.

02-32	Z signal calibration enabling		Factory setting	0
	Setting range	0	OFF	
		1	ON	

When servo ON, the position of the rotor magnetic poles can be corrected through the encoder Z signal.

02-43	Zero speed enabling		↗	Factory setting	0
	Setting range	0	OFF		
		1	ON		
02-44	Switchover frequency		↗	Factory setting	0.30Hz
	Setting range	0.00Hz~02-02			
02-45	Zero speed KP		↗	Factory setting	10
	Setting range	1~100			
02-46	Zero speed TI		↗	Factory setting	0.50s
	Setting range	0.01s~10.00s			

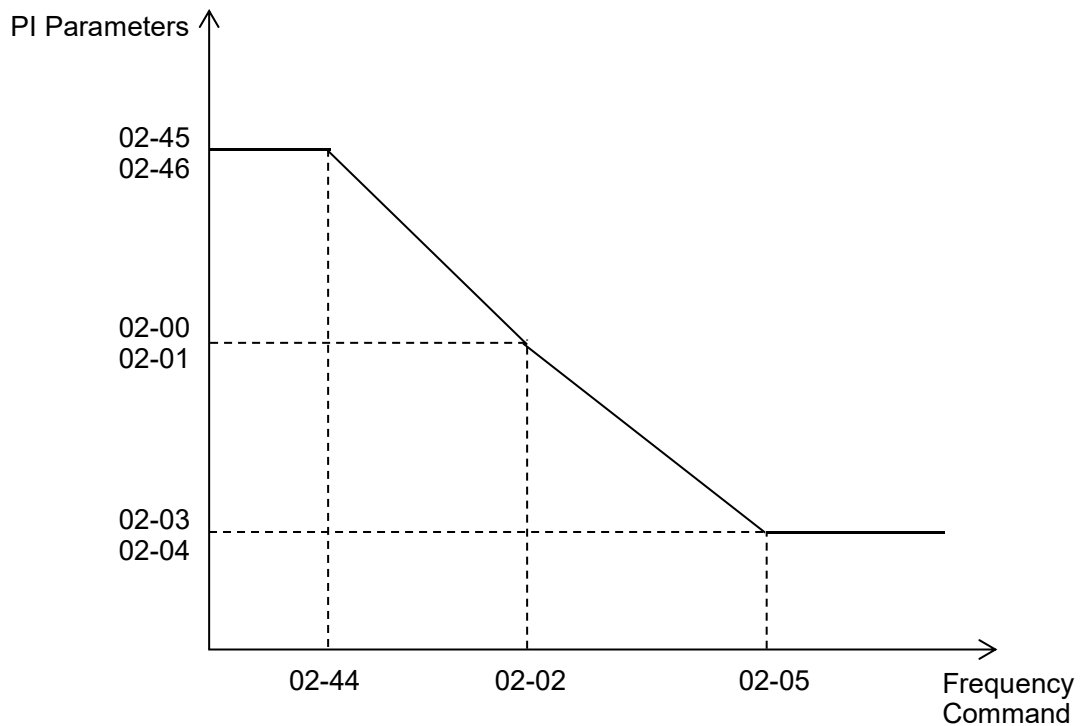

Figure 5-3 Schematic Diagram of 3-Stage PI Parameters

03 V/f Control Parameters

Group 03 parameters are only valid for V/f control, not for vector control.

03-00	V/f curve setting	Factory setting	0
	Setting range	0	Straight line V/f
		1	Multi-point V/f

0: Straight line V/f. Suitable for ordinary constant torque loads.

1: Multi-point V/f. Suitable for special loads such as dehydrator and centrifuge. By setting 03-03~03-08 parameters, you can get any V/f curve.

03-01	Torque boost	↗	Factory setting	Type setting
	Setting range	0.0%:(auto-torque boost) 0.1%~30.0%		
03-02	Cut-off frequency of torque boost	Factory setting	50.00Hz	
	Setting range	0.00Hz~max frequency		

Torque boosting can improve the low-frequency torque characteristics of V/f and do boost compensation for the output voltage. However, if the torque boost setting is too large, the motor is easily overheated and the inverter is easily overcurrent.

When the torque boost is set to 0.0, the inverter is in automatic torque boost, and the inverter automatically calculates the torque boost value according to the motor stator resistance and other parameters.

Torque boost torque cut-off frequency: Below this frequency, the torque boost is valid, and beyond this set frequency, the torque boost is invalid, as shown in Figure 5-3.

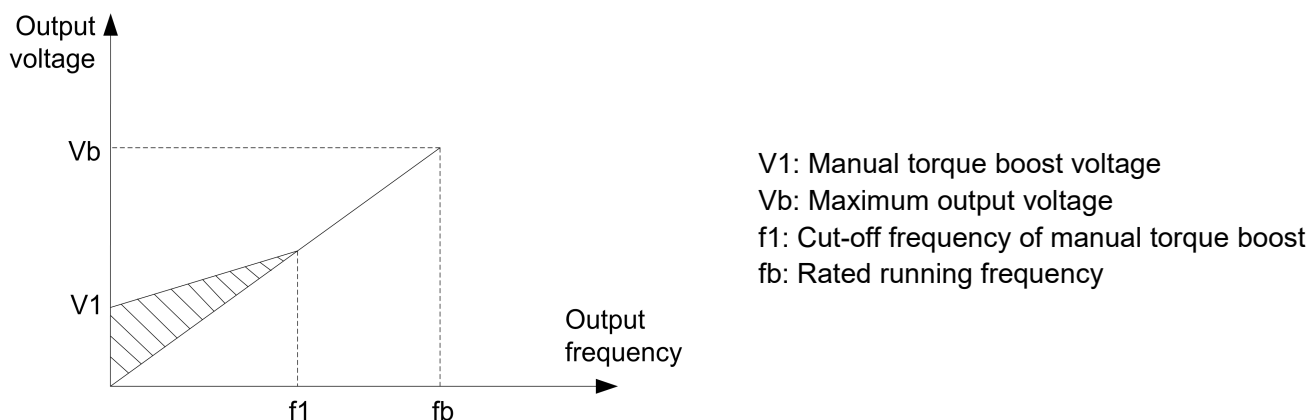

Figure 5-3 Schematic diagram of manual torque boost

03-03	Multi-point V/f frequency point 1	Factory setting	0.00Hz
	Setting range	0.00Hz~03-05	
03-04	Multi-point V/f voltage point 1	Factory setting	0.0%
	Setting range	0.0%~100.0%	
03-05	Multi-point V/f frequency point 2	Factory setting	0.00Hz
	Setting range	03-03~03-07	
03-06	Multi-point V/f voltage point 2	Factory setting	0.0%
	Setting range	0.0%~100.0%	
03-07	Multi-point V/f frequency point 3	Factory setting	0.00Hz
	Setting range	03-05~motor rated frequency(01-03)	
03-08	Multi-point V/f voltage point 3	Factory setting	0.0%
	Setting range	0.0%~100.0%	

Parameters 03-03~03-08 can define multi-segment V/f curve.

The curve of the multi-point V/f should be set according to the load characteristics of the motor. Note that the relationship between the three voltage points and the frequency point must meet: $V1 < V2 < V3$, $F1 < F2 < F3$. Figure 5-4 is a schematic diagram of multi-point V/f curve setting.

If the voltage is set too high at low frequency, the motor may overheat or even burn, and the inverter may be overcurrent stalled or overcurrent protected.

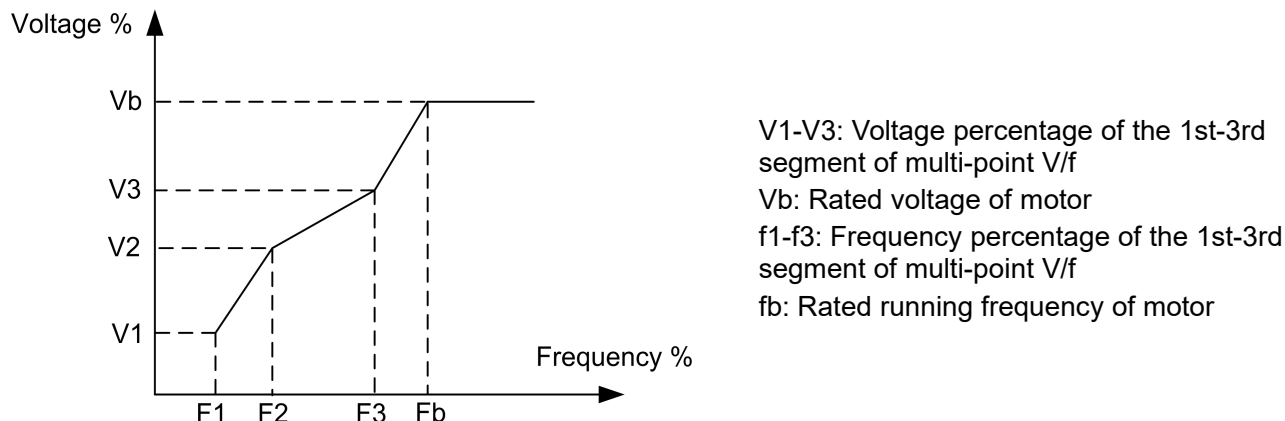

Figure 5-4 Schematic diagram of multi-point V/f curve setting.

03-09	V/f slip compensation gain	↗	Factory setting	0.0%
	Setting range	0.0%~200.0%		

V/f slip compensation can compensate the motor rotation deviation generated by the asynchronous motor when the load increases, so that the motor speed can be basically stabilized when the load changes.

03-10	V/f overexcitation gain	↗	Factory setting	64
	Setting range	0~200		

During the deceleration of the inverter, the overexcitation control can suppress the rise of the bus voltage and avoid overvoltage faults. The greater the gain, the stronger the suppression effect. However, if the overexcitation gain is too large, the output current is likely to increase, and a moderate setting is required. For applications where the inertia is small or the braking resistor is used, the recommended gain is set to zero.

03-11	V/f oscillation suppression gain	↗	Factory setting	Type setting
	Setting range	0~100		

The selection method of the gain is as small as possible under the premise of effectively suppressing the oscillation, so as to avoid adversely affecting the V/f operation. Select this gain to be 0 when there is no oscillation in the motor. It is only necessary to increase the gain appropriately when the motor oscillates significantly. The greater the gain, the more obvious the suppression of the oscillation.

When using the suppression oscillation function, the motor rated current and no-load current parameters are required to be accurate, otherwise the V/f oscillation suppression effect is not good.

04 Input Terminal Parameters

04-00	MI1 terminal function selection	Factory setting	1
04-01	MI2 terminal function selection	Factory setting	2
04-02	MI3 terminal function selection	Factory setting	9
04-03	MI4 terminal function selection	Factory setting	0
04-04	MI5 Terminal function selection	Factory setting	0
04-05	MI6 terminal function selection	Factory setting	0
04-06	MI7 terminal function selection	Factory setting	0
04-07	MI8 terminal function selection	Factory setting	0
04-08	MI9 terminal function selection	Factory setting	0
04-09	MI10 terminal function selection	Factory setting	0

These parameters are used to set the function of the digital multi-function input terminal Terminal. The functions that can be selected are shown in the following table:

Setting value	Function	Description
0	No function	It is recommended to set the unused terminals to “no function” to prevent malfunction.
1	Forward running(FWD)	Control inverter forward and reverse running through external terminals.
2	Reverse running(REV)	
3	Three-wire control	This terminal is used to determine the inverter operation mode is the three-wire control mode. For details, please refer to the description of parameter 04-09 (terminal command mode).
4	Forward jog(FJOG)	Jog running frequency, jog acceleration and deceleration time, see the description of parameters 09-00, 09-01, 09-02.
5	Reverse jog(RJOG)	
6	Terminal UP	The frequency increment and decrement instructions are modified when the frequency is given by the external terminal. When the frequency source is set to digital setting, the set frequency can be adjusted up and down.
7	Terminal DOWN	
8	Coast to stop	The inverter blocks the output, and the motor's stopping process is not controlled by the inverter.
9	Fault reset(RESET)	A fault reset can be achieved by using a terminal for fault reset. Same as keyboard RESET.
10	Run pause	The inverter decelerates to stop, but all running parameters are memorized. Such as PLC parameters, wobble frequency parameters, PID parameters. After the terminal signal disappears, the inverter returns to the operating state before stopping.
11	Normally open input for external fault	When the signal is valid, the inverter reports the fault EF and performs fault processing according to the fault protection action mode (details participate in parameters 11-47).
12	Multi-step speed terminal 1	Through the combination of the states of the four terminals, the 16-speed setting or the setting of 16 other commands can be realized. See appendix 1 for details.
13	Multi-step speed terminal 2	
14	Multi-step speed terminal 3	
15	Multi-step speed terminal 4	
16	Acceleration / deceleration time selection terminal 1	Through the four states of the two terminals, four types of acceleration and deceleration time are selected. See Table 2 for details.
17	Acceleration / deceleration time selection terminal 2	

Setting value	Function	Description
18	Frequency source switching	According to the setting of the frequency source selection parameter (00-17), when switching between two frequency sources is set as the frequency source, the terminal is used to switch between the two frequency sources.
19	UP/DOWN set to clear (terminal, keyboard)	When the frequency is given as digital timing, this terminal can clear the frequency value changed by terminal UP/DOWN or keyboard UP/DOWN, so that the given frequency is restored to the value set by 00-06.
20	Run command switching terminal	When the command source is terminal control (00-00=1), this terminal can switch between terminal control and keyboard control. When the command source is communication control (00-00=2), this terminal can switch between communication control and keyboard control.
21	Acceleration / deceleration prohibited	Ensure that the inverter is not affected by external signals (except the stop command) and maintain the current output frequency.
29	Torque control prohibited	The inverter is prohibited from torque control, the inverter enters the speed control mode
32	Immediate DC braking	When this terminal is valid, the inverter directly switches to the DC braking state
33	Normally closed input for external fault	When this signal is valid, the inverter reports fault EF and stops.
34	Frequency modification enable	When this function is valid, the inverter does not respond to changes in frequency commands.
36	External stop terminal 1	During keyboard control, this terminal can be used to stop the inverter, which is equivalent to the function of the STOP key on the keyboard.
37	Control command switching terminal 2	This function is used to switch between terminal control and communication control.
39	Frequency source X and keyboard set frequency switching	When this terminal is valid, the frequency source X is replaced with the frequency given by the keyboard (00-06)
40	Frequency source Y and keyboard set frequency switching	When this terminal is valid, the frequency source Y is replaced with the frequency given by the keyboard (00-06)
46	Speed control/torque control switching	Switch the inverter between torque control and speed control mode. When this terminal is invalid, the inverter runs in the mode defined by 17-00 (Speed/Torque Control Mode). When this terminal is valid, it switches to another mode.
47	Emergency stop	When this terminal is valid, the inverter stops at the fastest speed, and the current is in the upper limit of the set current during this stop. This function is used to meet the occasions where the inverter needs to stop as soon as possible when the system is in an emergency state.
48	External stop terminal 2	In any command control mode (panel control, terminal control, communication control), the terminal can be used to decelerate the inverter to stop, and the deceleration time is fixed at 4 deceleration time.
49	Deceleration DC braking	When this terminal is valid, the inverter decelerates to the initial frequency of DC braking at stop, and then switches to DC braking.
50	Clear the current running time	When this terminal is valid, the timing time of the inverter's current operation is cleared. This function needs to be used in conjunction with the timing operation (09-42) and the current operation time arrival (09-53).

Setting value	Function	Description
53	Contactor output feedback	This terminal is used for elevator specific commands (00-02 is set to 3) to detect the control status of the contactor between the driver and the motor.
54	Brake output feedback	This terminal is used for elevator specific commands (00-02 set to 3) to detect the output status of the brake.
55	En enabling	This terminal is designed for elevator-specific commands (setting 00-02 to 3) to enable the inverter output.
56	Emergency power supply	This terminal is designated for elevator-specific commands (setting 00-02 to 3). When active, it operates on low-voltage emergency power supply.

Attached Table 1 Multi-step speed command function description

Four multi-speed command terminals can be combined into 16 states, and these 16 states correspond to 16 command setting values. As shown in Table 1:

K4	K3	K2	K1	Command setting	Corresponding parameters
OFF	OFF	OFF	OFF	Multi-step speed command 0	05-00
OFF	OFF	OFF	ON	Multi-step speed command 1	05-01
OFF	OFF	ON	OFF	Multi-step speed command 2	05-02
OFF	OFF	ON	ON	Multi-step speed command 3	05-03
OFF	ON	OFF	OFF	Multi-step speed command 4	05-04
OFF	ON	OFF	ON	Multi-step speed command 5	05-05
OFF	ON	ON	OFF	Multi-step speed command 6	05-06
OFF	ON	ON	ON	Multi-step speed command 7	05-07
ON	OFF	OFF	OFF	Multi-step speed command 8	05-08
ON	OFF	OFF	ON	Multi-step speed command 9	05-09
ON	OFF	ON	OFF	Multi-step speed command 10	05-10
ON	OFF	ON	ON	Multi-step speed command 11	05-11
ON	ON	OFF	OFF	Multi-step speed command 12	05-12
ON	ON	OFF	ON	Multi-step speed command 13	05-13
ON	ON	ON	OFF	Multi-step speed command 14	05-14
ON	ON	ON	ON	Multi-step speed command 15	05-15

When the frequency source is set to multi-speed, the parameter 05-00~05-15 as the frequency source.

Attached Table 2 Acceleration and deceleration time terminal function description

Terminal 2	Terminal 1	Acceleration or deceleration time selection	Corresponding parameters
OFF	OFF	Acceleration time 1	00-07,00-08
OFF	ON	Acceleration time 2	09-03,09-04
ON	OFF	Acceleration time 3	09-05,09-06
ON	ON	Acceleration time 4	09-07,09-08

04-10	MI Filter time	↗	Factory setting	0.010s
	Setting range	0.000s~1.000s		

Set the software filtering time for the terminal state of the MI terminal. If the input terminal of the application occasion is susceptible to interference and cause malfunctions, this parameter can be increased to enhance the anti-interference ability. However, the increase of the filtering time will cause the response of the MI terminal to become slow.

04-11	Terminal command mode	Factory setting	0
	Setting range	0	Two-wire 1
		1	Two-wire 2
		2	Three-wire 1
		3	Three-wire 2

This parameter defines four different ways to control the operation of the inverter through the external terminal Terminal.

0: Two-wire mode 1: This mode is the most commonly used two-wire mode.

Terminal Reverse running is determined by TerminalMlx and Mly.

The terminal terminal function settings are as follows:

Terminal	Setting value	Description
Mlx	1	Forward running(FWD)
Mly	2	Reverse running(REV)

Among them, Mlx and Mly are the multi-function input terminals Terminal of MI1~MI5, the level is effective.

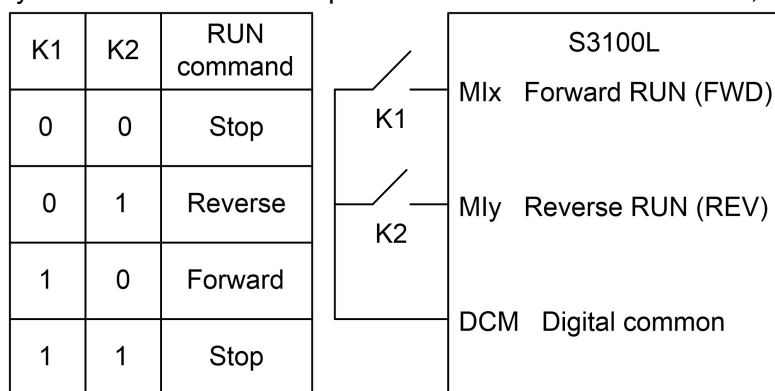

Figure 5-6 Two-wire mode 1

1: Two-wire mode 2: When using this mode, the terminal function of the Mlx terminal is the running enable terminal, and the terminal function of the Mly terminal determines the running direction.

The terminal terminal function settings are as follows:

Terminal	Setting value	Description
Mlx	1	Forward running(FWD)
Mly	2	Reverse running(REV)

Among them, Mlx and Mly are the multi-function input terminals Terminal of MI1~MI5, the level is effective.

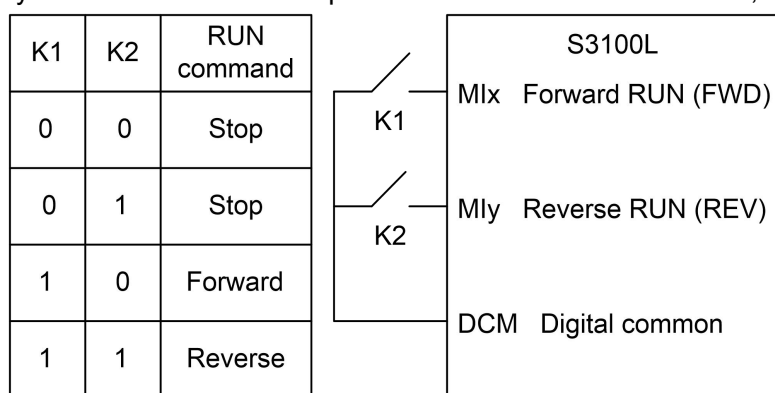

Figure 5-7 Two-wire mode 2

2: Three-wire control mode1: This mode MIn is the enable terminal, the direction is controlled by Mlx and Mly respectively.

The terminal terminal function settings are as follows:

Terminal	Setting value	Description
Mlx	1	Forward running(FWD)
Mly	2	Reverse running(REV)
Mln	3	Three-wire running control

When you need to run, you must first close the Mln terminal, and realize the forward or reverse control of the motor by the rising edge of the pulse of Mlx or Mly.

When it is necessary to stop, it must be achieved by disconnecting the terminal signal of the Mln terminal. Among them, Mlx, Mly, Mln are multi-function input terminals Terminal MI1 ~ MI5, Mlx, Mly are pulse effective, Mln is level effective.

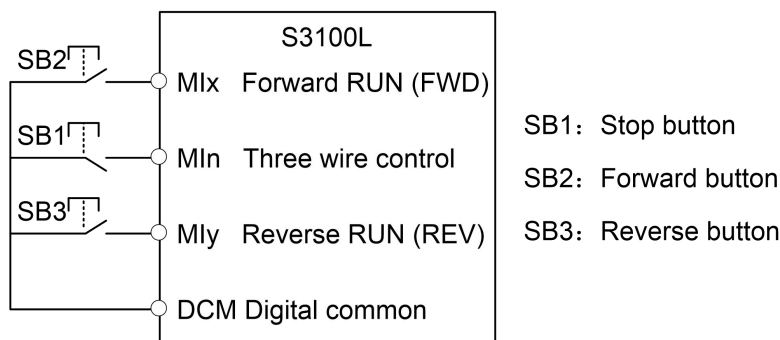

Figure 5-8 Three-wire control mode 1

3: Three-wire control mode 2: The enable terminal I in this mode is Mln, the running command is given by Mlx, and the direction is determined by the state of Mly.

The terminal terminal function settings are as follows:

Terminal	Setting value	Description
Mlx	1	Forward running(FWD)
Mly	2	Reverse running(REV)
Mln	3	Three-wire running control

When you need to run, you must first close the Mln terminal, the Mlx pulse rising edge generates the motor running signal, and the Mly state generates the motor direction signal.

When it is necessary to stop, it must be achieved by disconnecting the terminal signal of the Mln terminal. Among them, Mlx, Mly, and Mln are the multi-function input terminals of MI1 to MI5, Mlx is pulse effective, and Mly, Mln are level effective.

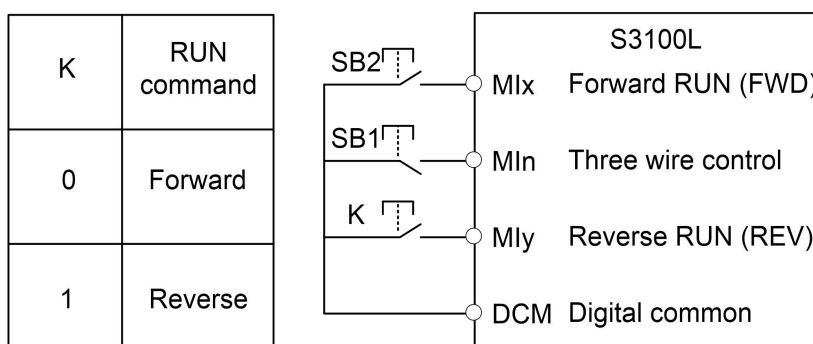

SB1: Stop button SB2: RUN button

Figure 5-9 Three-wire control mode 2

04-12	Terminal UP/DOWN change rate	↗	Factory setting	1.00Hz/s
	Setting range	0.01Hz/s~65.535Hz/s		

Used to set the terminal UP/DOWN to adjust the set frequency, the speed of frequency change, that is the amount of frequency change per second.

When 00-25 (frequency decimal point) is 2, the value range is 0.001Hz/s~65.535Hz/s. When 00-25 (frequency decimal point) is 1, the value range is 0.01Hz/s~655.35Hz/s.

04-13	AVI curve 1 lower limit	↗	Factory setting	0.10V
	Setting range	0.00V~04-15		
04-14	Corresponding setting of AVI curve 1 lower limit	↗	Factory setting	0.0%
	Setting range	-100.0%~+100.0%		
04-15	AVI curve 1 upper limit	↗	Factory setting	10.00V
	Setting range	04-13~+10.00V		
04-16	Corresponding setting of AVI curve 1 upper limit	↗	Factory setting	100.0%
	Setting range	-100.0%~+100.0%		
04-17	AVI1 filter time	↗	Factory setting	0.10s
	Setting range	0.00s~10.00s		

The relationship between the above parameter analog input voltage and the setting value it represents.

When the analog input voltage exceeds the set range of the maximum input or minimum input, it will be calculated as the maximum input or minimum input.

When the analog input is current input, 0mA~20mA current corresponds to 0V~5V Voltage.

In different applications, the meaning of the nominal value corresponding to 100.0% of the analog setting is different. For details, please refer to the description of each application.

The following illustrations show two typical settings:

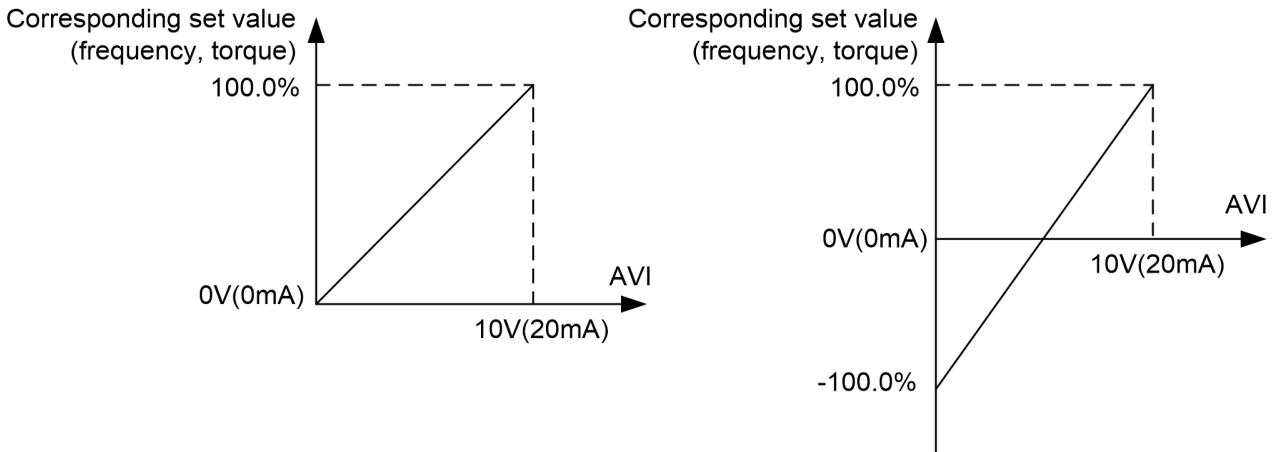

Figure 5-10 Correspondence relationship between analog input and set value

AVI1 input filter time: adjust the sensitivity of analog input. Properly increasing this value can enhance the anti-interference of the analog quantity, but it will reduce the sensitivity of the analog input.

04-18	AVI curve 2 lower limit	↗	Factory setting	0.10V
	Setting range	0.00V~04-20		
04-19	Corresponding setting of AVI curve 2 lower limit	↗	Factory setting	0.0%
	Setting range	-100.0%~+100.0%		
04-20	AVI curve 2 upper limit	↗	Factory setting	10.00V
	Setting range	04-18~+10.00V		
04-21	Corresponding setting of AVI curve 2 upper limit	↗	Factory setting	100.0%
	Setting range	-100.0%~+100.0%		
04-22	AVI2/ACI filter time	↗	Factory setting	0.10s
	Setting range	0.00s~10.00s		

For the method of setting AVI curve 2 function, please refer to the description of AVI curve 1.

Analog AVI2/ACI can support 0~10V or 0~20mA input. When AVI2/ACI selects 0~20mA input, the corresponding Voltage of 20mA is 5V.

04-33	AVI curve selection		↗	Factory setting	321
	Setting range	Single digit	AVI 1 curve selection		
		1	AVI curve 1(2 points,refer to 04-11~04-14)		
		2	AVI curve 2(2 points,refer to 04-16~04-19)		
		3	Reserved		
		4	Reserved		
		5	Reserved		
		Tens digital	AVI2/ACI curve selection, same as above		
		Hundreds digital	Reserved		

The single digit and tens digital of this parameter are used to select the setting curve corresponding to analog input AVI1, AVI2/ACI respectively.

Two kinds of analog input can choose any one of two kinds of curves.

04-34	AVI is less than the minimum input setting selection		↗	Factory setting	000
	Setting range	Single digit	AVI1 is less than the minimum input setting selection		
		0	Corresponding analog lower limit		
		1	0.0%		
		Tens digital	AVI2/ACI is less than the minimum input setting selection, same as above		

This parameter is used to select the analog value when the analog input voltage is less than the set "minimum input".

The analog lower limit value refers to the less limit value of parameters 04-11 and 04-16.

If the selection is 1, when the AVI input is less than the minimum input, the corresponding setting of the analog quantity is 0.0%.

04-35	MI1 delay time		↗	Factory setting	0.0s
	Setting range	0.0s~3600.0s			
04-36	MI2 delay time		↗	Factory setting	0.0s
	Setting range	0.0s~3600.0s			
04-37	MI3 delay time		↗	Factory setting	0.0s
	Setting range	0.0s~3600.0s			

It is used to set the delay time for the inverter to change the terminal state when the MI terminal changes.

Currently, only MI1, MI2, and MI3 have the function of setting the delay time.

04-38	MI terminal valid mode selection 1		↗	Factory setting	0
	Setting range	0	High level valid		
		1	Low level valid		
		Single digit	MI1		
		Tens digital	MI2		
		Hundreds digital	MI3		
		Thousands digital	MI4		
		Ten thousands digital	MI5		

04-39	MI terminal valid mode selection 2		Factory setting	0
	Setting range	0	High level valid	
		1	Low level valid	
		Single digit	MI6	
		Tens digital	MI7	
		Hundreds digital	MI8	
		Thousands digital	MI9	
		Ten thousands digital	MI10	

Used to set the active status mode of the digital input terminal. When the selection is active high, the corresponding MI terminal is valid when connected to the DCM, and the disconnection is invalid. When the selection is active low, the corresponding MI terminal is invalid when it is connected to the DCM, and the disconnection is valid.

05 Multi-Speed

The S3100L's multi-speed commands are more comprehensive than standard models. In addition to basic multi-speed functions, it features selectable acceleration/deceleration time groups for each speed segment, along with customizable S-curve ratio groups for S-curve operations.

05-00	Multi-step speed command 0	↗	Factory setting	0.00Hz
05-01	Multi-step speed command 1	↗	Factory setting	0.00Hz
05-02	Multi-step speed command 2	↗	Factory setting	0.00Hz
05-03	Multi-step speed command 3	↗	Factory setting	0.00Hz
05-04	Multi-step speed command 4	↗	Factory setting	0.00Hz
05-05	Multi-step speed command 5	↗	Factory setting	0.00Hz
05-06	Multi-step speed command 6	↗	Factory setting	0.00Hz
05-07	Multi-step speed command 7	↗	Factory setting	0.00Hz
05-08	Multi-step speed command 8	↗	Factory setting	0.00Hz
05-09	Multi-step speed command 9	↗	Factory setting	0.00Hz
05-10	Multi-step speed command 10	↗	Factory setting	0.00Hz
05-11	Multi-step speed command 11	↗	Factory setting	0.00Hz
05-12	Multi-step speed command 12	↗	Factory setting	0.00Hz
05-13	Multi-step speed command 13	↗	Factory setting	0.00Hz
05-14	Multi-step speed command 14	↗	Factory setting	0.00Hz
05-15	Multi-step speed command 15	↗	Factory setting	0.00Hz
	Setting range	0.00Hz~00-03		

05-18	Multi-speed Command 0: S Curve Ratio Selection	↗	Factory setting	0
05-20	Multi-speed Command 1: S Curve Ratio Selection	↗	Factory setting	0
05-22	Multi-speed Command 2: S Curve Ratio Selection	↗	Factory setting	0
05-24	Multi-speed Command 3: S Curve Ratio Selection	↗	Factory setting	0
05-26	Multi-speed Command 4: S Curve Ratio Selection	↗	Factory setting	0
05-28	Multi-speed Command 5: S Curve Ratio Selection	↗	Factory setting	0
05-30	Multi-speed Command 6: S Curve Ratio Selection	↗	Factory setting	0
05-32	Multi-speed Command 7: S Curve Ratio Selection	↗	Factory setting	0

05-34	Multi-speed Command 8: S Curve Ratio Selection	↘	Factory setting	0
05-36	Multi-speed Command 9: S Curve Ratio Selection	↘	Factory setting	0
05-38	Multi-speed Command 10: S Curve Ratio Selection	↘	Factory setting	0
05-40	Multi-speed Command 11: S Curve Ratio Selection	↘	Factory setting	0
05-42	Multi-speed Command 12: S Curve Ratio Selection	↘	Factory setting	0
05-44	Multi-speed Command 13: S Curve Ratio Selection	↘	Factory setting	0
05-46	Multi-speed Command 14: S Curve Ratio Selection	↘	Factory setting	0
05-48	Multi-speed Command 15: S Curve Ratio Selection	↘	Factory setting	0
	Setting range	0:07-12,07-13 1:24-04,24-05 2:24-06,24-07 3:24-08,24-09		

05-19	Multi-speed command 0: Acceleration and deceleration time selection	↘	Factory setting	0
05-21	Multi-speed command 1: Acceleration and deceleration time selection	↘	Factory setting	0
05-23	Multi-speed command 2: Acceleration and deceleration time selection	↘	Factory setting	0
05-25	Multi-speed command 3: Acceleration and deceleration time selection	↘	Factory setting	0
05-27	Multi-speed command 4: Acceleration and deceleration time selection	↘	Factory setting	0
05-29	Multi-speed command 5: Acceleration and deceleration time selection	↘	Factory setting	0
05-31	Multi-speed command 6: Acceleration and deceleration time selection	↘	Factory setting	0
05-33	Multi-speed command 7: Acceleration and deceleration time selection	↘	Factory setting	0
05-35	Multi-speed command 8: Acceleration and deceleration time selection	↘	Factory setting	0
05-37	Multi-speed command 9: Acceleration and deceleration time selection	↘	Factory setting	0
05-39	Multi-speed command 10: Acceleration and deceleration time selection	↘	Factory setting	0
05-41	Multi-speed command 11: Acceleration and deceleration time selection	↘	Factory setting	0
05-43	Multi-speed command 12: Acceleration and deceleration time selection	↘	Factory setting	0
05-45	Multi-speed command 13: Acceleration and deceleration time selection	↘	Factory setting	0
05-47	Multi-speed command 14: Acceleration and deceleration time selection	↘	Factory setting	0
05-49	Multi-speed command 15: Acceleration and deceleration time selection	↘	Factory setting	0
	Setting range	0:00-07,00-08 1:09-03,09-04 2:09-05,09-06 3:09-07,09-08		

05-51	Multi-speed command given mode	↗	Factory setting	0
	Setting range	0	Parameter 05-00 given	
		1	AVI1	
		2	AVI2/ACI	
		3	Reserved	
		4	Reserved	
		5	Reserved	
		6	The keyboard setting frequency (00-06) is given, UP/DOWN can be modified	

This parameter determines the given channel of Multi-step speed command 0.

Example

When selecting multi-speed segments (00-02 for 4 or 10) and the S-curve (07-11 for 5), the speed settings are: 05-18 (speed 0) = 0, 05-19 (speed 0) = 0, 05-20 (speed 1) = 1, 05-21 (speed 1) = 1, 05-22 (speed 2) = 2, 05-23 (speed 2) = 2, 05-24 (speed 3) = 3, 05-25 (speed 3) = 3. The corresponding speed explanations are illustrated in the diagram below.

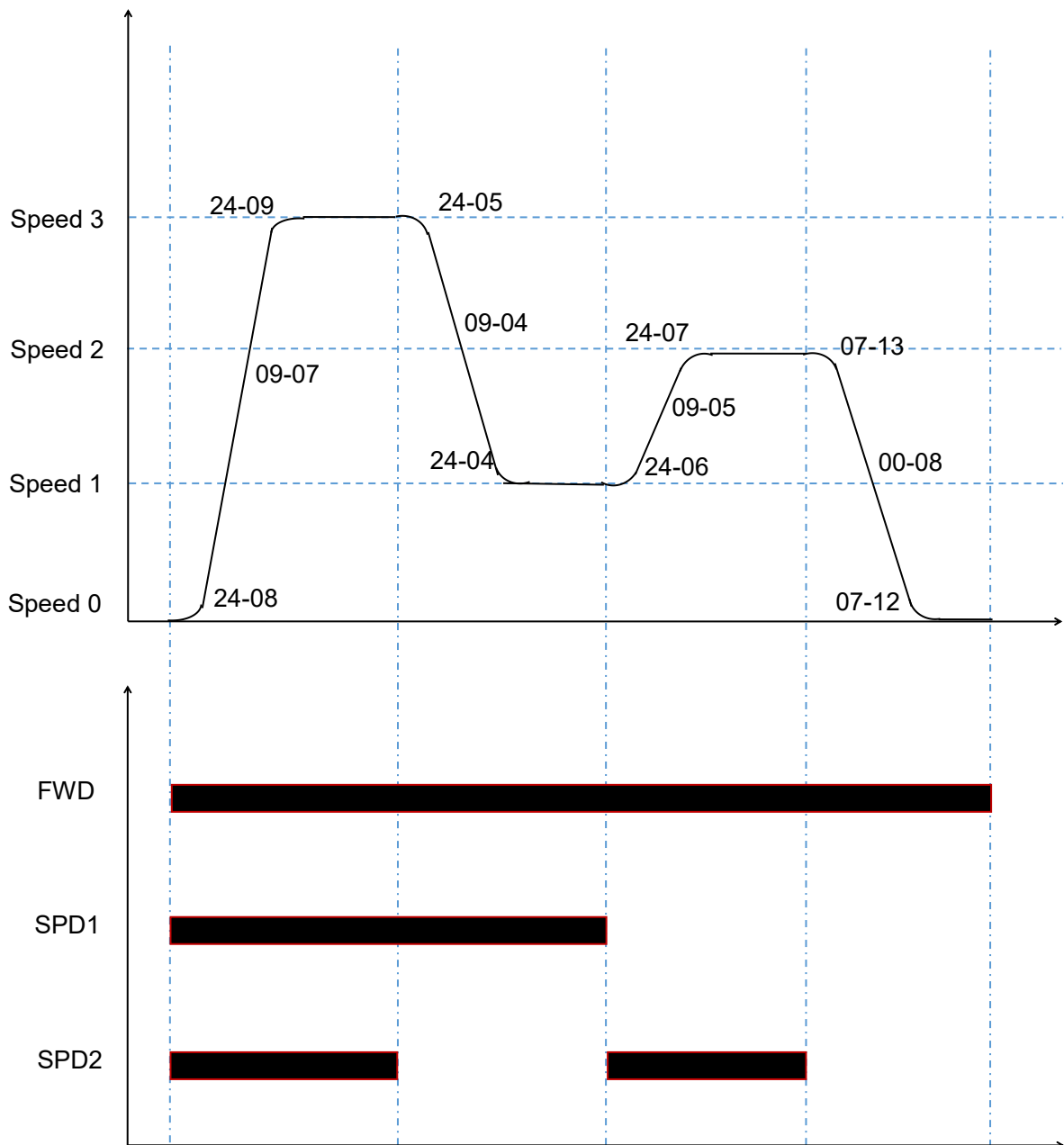

Figure 5-11 Schematic diagram of Multi-speed correlation parameters

06 Output Terminal Parameters

S3100L series inverters are equipped with a multi-function analog output terminal Terminal, a multi-function digital output terminal Terminal, 3 multi-function relay output terminal Terminal, a DFM terminal Terminal (can be used as high-speed pulse output terminal Terminal, also can be used as an open collector switch output).

06-00	MO1 output function selection	↗	Factory setting	1
06-01	RA-RB-RC output function selection	↗	Factory setting	2
06-02	RA1-RC1 output function selection	↗	Factory setting	0
06-03	RA2-RC2 output function selection	↗	Factory setting	0
06-04	DFM(M) output function selection	↗	Factory setting	0

The function descriptions of the multi-function output terminals are as follows:

Setting value	Function	Description
0	No output	Output terminal is invalid
1	Inverter is running	Indicates that the inverter is in running state and has an output frequency (which can be zero), at this time it outputs an ON signal
2	Fault output (stop)	When the inverter is faulty and the fault is stopped, the ON signal is output.
3	Frequency level detection FDT1 output	Please refer to the parameters 09-19,09-20
4	Frequency reached	Please refer to the parameters 09-21
5	Running at zero speed (No output when stopped)	When the inverter is running and the output frequency is 0, the ON signal is output. When the inverter is stopped, this signal is OFF.
6	Motor overload pre-alarm	Before the overload protection action of the motor, the judgment is based on the threshold value of the overload pre-alarm, and the ON signal is output after the pre-alarm threshold is exceeded. Refer to parameters 11-00~11-02 for motor overload parameter setting.
7	Inverter overload pre-alarm	10s before the inverter overload protection occurs, output ON signal.
12	Cumulative running time arrived	When the cumulative running time of the inverter exceeds the time set in 09-17, it outputs an ON signal.
13	Frequency limited	When the set frequency exceeds the upper limit frequency or lower limit frequency, and the output frequency of the inverter reaches the upper limit frequency or lower limit frequency, an ON signal is output.
14	Torque limited	In the speed control mode of the frequency converter, when the output torque reaches the torque limit value, the frequency converter is in the stall protection state and outputs an ON signal at the same time.
15	Ready for run	When the power supply of the main circuit and the control circuit of the inverter has stabilized, and the inverter has not detected any fault information, and the inverter is in a operable state, it outputs an ON signal.
16	AVI1>AVI2/ACI	When the value of analog input AVI1 is greater than the input value of AVI2/ACI, an ON signal is output.
17	Upper limit frequency reached	When the running frequency reaches the upper limit frequency, the ON signal is output.
18	Lower limit frequency reached (operation valid)	When the running frequency reaches the lower limit frequency, the ON signal is output. The output is OFF in the stop state.
19	Undervoltage state output	When the inverter is undervoltage state, it outputs ON signal.
20	Communication setting	Please refer to the communication protocol.
21	Reserved	Reserved

Setting value	Function	Description
22	Reserved	Reserved
23	Zero speed running 2 (also output when stopped)	When the output frequency of the inverter is 0, the ON signal is output. This signal is also ON in the stop state.
24	Cumulative power-on time arrival	When the cumulative power-on time (08-13) of the inverter exceeds the set time of 09-16, it outputs an ON signal.
25	Frequency level detection FDT2 output	Please refer to the parameters 09-28,09-29
26	Frequency 1 reaches the output	Please refer to the parameters 09-30,09-31
27	Frequency 2 reaches the output	Please refer to the parameters 09-32,09-33
28	Current 1 reaches the output	Please refer to the parameters 09-38,09-39
29	Current 2 reaches the output	Please refer to the parameters 09-40,09-41
30	Timing reached	When the timing function selection (09-42) is valid, the inverter will output an ON signal after the current running time of the inverter reaches the set time.
31	AVI1 input exceeds limit	When the value of analog input AVI1 is greater than 09-46 (AVI1 input protection upper limit) or less than 09-45 (AVI1 input protection lower limit), ON signal is output.
32	Lost load	When the inverter is in the load drop state, it outputs ON signal.
33	Reverse running	When the inverter is running in reverse, output ON signal
34	Zero current state	Please refer to the parameters 09-34,09-35
35	Module temperature reached	Inverter module radiator temperature (08-08) reaches the set module temperature reached value(09-47), output ON signal
36	Software current limit exceeded	Please refer to the parameters 09-36,09-37
37	Lower limit frequency reached (also output when stopped)	When the running frequency reaches the lower limit frequency, the ON signal is output. The signal is also ON in the stop state.
38	Warning output	When the inverter fails, and the fault handling mode is Continue to run, the inverter warning output.
39	Reserved	Reserved
40	Current running time reached	When the inverter's current running time exceeds the time set in 09-53, it outputs an ON signal.
42	Contact output	This terminal is used for elevator specific commands (set as 3 for 00-02), and is used to control the contactor between the driver and the motor.
43	Brake output	This terminal is used for elevator specific commands (set 00-02 as 3) to control the brake.

06-05	DFM terminal output mode selection	↗	Factory setting	1
	Setting range	0	Reserved	
		1	Switch output(DFM(M))	

When DFM(M) is output as a switch, please refer to 06-04 for DFM(M) related functions.

06-17	MO1 output delay time	↗	Factory setting	0.0s
06-18	Relay RA-RB-RC output delay time	↗	Factory setting	0.0s
06-19	Relay RA1-RC1 output delay time	↗	Factory setting	0.0s
06-20	Relay RA2-RC2 output delay time	↗	Factory setting	0.0s
	Setting range	0.0s~3600.0s		

Set the delay time for the output terminal Terminal to change from the state to the actual output.

07 Start and Stop Control Parameters

07-00	Startup mode		↗	Factory setting	0
	Setting range	0	Direct start		
		1	Rotation speed tracking restart		
		2	Pre-excitation start		

0: Direct start:

If the startup DC braking time is set to 0, the inverter starts to run from the startup frequency. If the startup DC braking time is not 0, then DC braking first, and then start running from the startup frequency. Applicable to small inertial loads, where the motor may rotate when starting.

1: Rotation speed tracking restart:

The inverter first judges the speed and direction of the motor, and then starts at the tracked motor frequency, and implements the smoothing of the rotating motor.

Start without sliding. It is suitable for restart after instantaneous power failure of large inertia load. In order to ensure the performance of speed tracking and restart, it is necessary to set the motor 01 group parameters accurately.

2: Pre-excitation start:

Used to establish the magnetic field before the motor runs. For the pre-excitation current and time, please refer to the description of parameters 07-03 and 07-04.

If the pre-excitation time is set to 0, the inverter cancels the pre-excitation process and starts from the startup frequency. If the pre-excitation time is not 0, pre-excitation first and then start, can improve the dynamic response performance of the motor.

07-01	Startup frequency		↗	Factory setting	0.00Hz
	Setting range	0.00Hz~10.00Hz			
07-02	Startup frequency holding time			Factory setting	0.0s
	Setting range	0.0s~100.0s			

The inverter starts to run from the startup frequency (07-01), after the startup frequency holding time (07-02), then accelerates to the target frequency according to the set acceleration time.

The startup frequency 07-01 is not limited by the lower limit frequency. However, when the set target frequency is less than the startup frequency, the inverter does not start and is in a standby state.

During the switching between forward and reverse rotation, the startup frequency holding time has no effect. The startup frequency holding time is not included in the acceleration time, but included in the running time of the simple PLC.

07-03	Startup DC braking current / pre-excitation current		Factory setting	0%	
	Setting range	0%~100%			
07-04	Startup DC braking time/pre-excitation time			Factory setting	0.0s
	Setting range	0.0s~100.0s			

Startup DC braking is only effective when the starting mode is direct start. At this time, the inverter performs DC braking according to the set startup DC braking current, and then starts running after the startup DC braking time. If the DC braking time is set to 0, DC braking is invalid. The greater the DC braking current, the greater the braking force.

If the startup mode is asynchronous motor pre-excitation start, the inverter first establishes the magnetic field according to the set pre-excitation current, and then starts running after the pre-excitation time.

If the pre-excitation time is set to 0, the pre-excitation is invalid and starts directly.

The startup DC braking current/pre-excitation current is a percentage of the rated current of the inverter.

07-05	Stop mode		↗	Factory setting	0
	Setting range	0	Decelerate to stop		
		1	Coast to stop		

0: Decelerate to stop after the stop command is valid, the inverter reduces the output frequency according to the deceleration time, and stops after the frequency drops to 0.

1: After the coast stop command is valid, the inverter immediately terminates the output, and the motor coasts to stop according to the mechanical inertia.

07-06	Starting frequency of DC braking at stop		↗	Factory setting	0.00Hz
	Setting range	0.00Hz~Max frequency			
07-07	DC braking waiting time at stop		↗	Factory setting	0.0s
	Setting range	0.0s~100.0s			
07-08	DC braking current at stop		↗	Factory setting	0%
	Setting range	0%~100%			
07-09	DC braking time at stop		↗	Factory setting	0.0s
	Setting range	0.0s~100.0s			

Starting frequency of DC braking at stop: When the running frequency is reduced to this frequency during deceleration to stop, the DC braking process starts.

Waiting time for DC braking at stop: After the running frequency is reduced to the initial frequency of DC braking at stop, the inverter will stop output for a period of time before starting the DC braking process. It is used to prevent overcurrent and other faults that may be caused by starting DC braking at a higher speed.

DC braking current at stop: refers to the output current Output current during DC braking, as a percentage of the motor rated current. The larger the value, the stronger the braking, but the greater the heat generated by the motor and inverter.

DC braking time at stop: The time the DC braking amount is maintained. This value is 0, the DC braking process is canceled. The DC braking process during shutdown is shown in the schematic diagram in Figure 5-12.

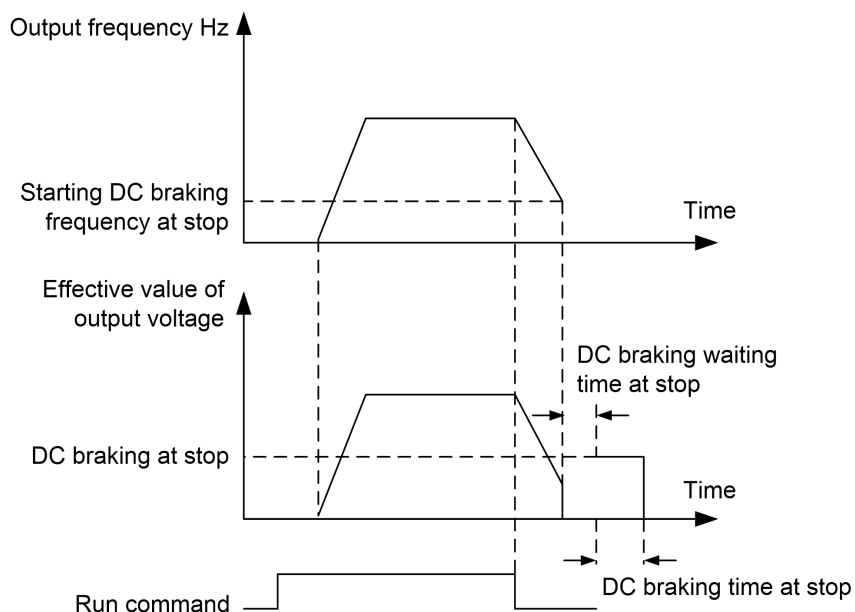

Figure 5-12 Schematic diagram of DC braking at shutdown

07-10	Brake usage		↗	Factory setting	80%
	Setting range	0%~100%			

It is only valid for the inverter with built-in braking unit.

The higher the braking usage rate, the stronger the braking effect, but the voltage fluctuation of the inverter bus voltage during braking is large.

07-11	Acceleration and deceleration mode			Factory setting	0
	Setting range	0	Linear acceleration / deceleration		
		1	S curve acceleration / deceleration A		
		5	S curve acceleration / deceleration B		

Select the frequency change method of the inverter during start and stop.

0: linear acceleration and deceleration

The output frequency increases or decreases in a straight line. 4 kinds of acceleration/deceleration time can be selected through multi-function digital input terminals (04-00~04-04).

1: S curve acceleration and deceleration A

The output frequency increases or decreases according to the S curve. The S curve is used in places that require gentle start or stop, such as elevators and conveyor belts. Parameters 07-12 and 07-13 respectively define the time proportion of the start and end segments of the S curve acceleration and deceleration

2: S curve acceleration and deceleration B

In this S curve acceleration/deceleration B, the rated frequency of the motor is always the inflection point of the S curve. As shown in Figure 5-14. It is generally used in high-speed areas above the rated frequency that require rapid acceleration and deceleration.

When the set frequency is above the rated frequency, the acceleration/deceleration time is:

$$f = \left(\frac{4}{9} \times \left(\frac{f}{f_b} \right)^2 + \frac{5}{9} \right) \times T$$

Among them, f is the set frequency, fb is the rated frequency of the motor, and T is the time from 0 frequency acceleration to the rated frequency fb.

07-12	S curve start time ratio	Factory setting	30.0%
	Setting range	0.0%~(100.0%-07-13)	
07-13	S curve end time ratio	Factory setting	30.0%
	Setting range	0.0%~(100.0%-07-12)	

Parameters 07-12 and 07-13 respectively define the start and end time ratios of the acceleration and deceleration of the S curve. The two parameters must meet: 07-12 + 07-13 ≤ 100.0%.

In Figure 5-13, t1 is the parameter defined by parameter 07-12. During this period of time, the slope of the output frequency change gradually increases. t2 is the time defined by parameter 07-13. During this time period, the slope of the output frequency change gradually changes to 0.

During the time between t1 and t2, the slope of the output frequency change is fixed, that is, linear acceleration and deceleration are performed in this interval.

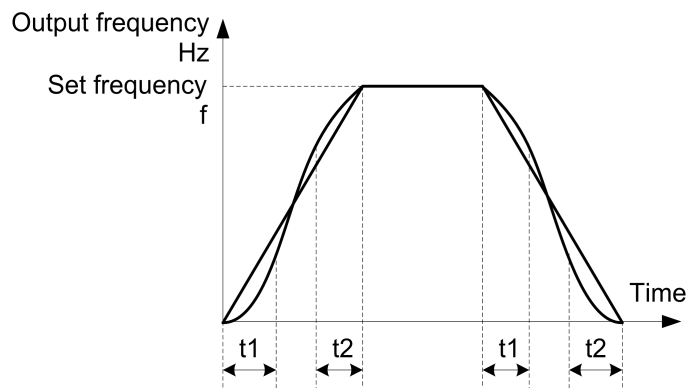

Figure 5-13 S curve acceleration and deceleration A

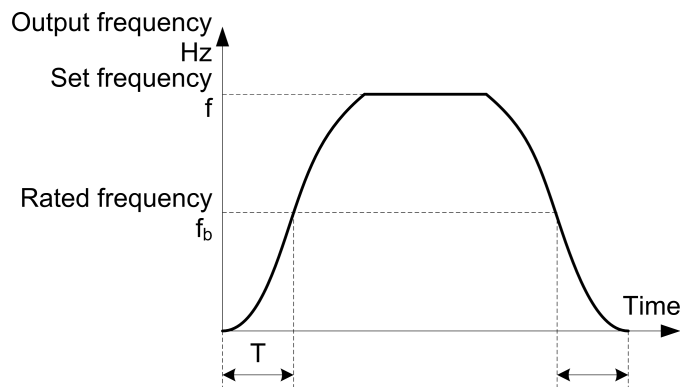

Figure 5-14 S curve acceleration and deceleration B

08 Man-machine Interface Parameters

08-00	User password	↗	Factory setting	0
	Setting range	0~65535		

08-00 sets any non-zero number, the password protection function takes effect. The next time you enter the menu, you must enter the password correctly, otherwise you cannot view and modify the function parameters, please remember the set user password.

Set 08-00 to 00000, then clear the set user password and invalidate the password protection function.

08-01	QUICK/JOG key function selection	↗	Factory setting	3
	Setting range	0	QUICK/JOG invalid	
		1	Keyboard command channel and remote command channel (terminal Terminal command channel or communication command channel) switch	
		2	Forward and reverse switching	
		3	Forward jog	
		4	Reverse jog	

QUICK/JOG is a multi-function key, and the function of QUICK/JOG key can be set through this parameter. You can use this key to switch between stop and running.

0: This button has no function.

1: Switch between keyboard command and remote operation. Refers to the switching of the command source, that is, the switching between the current command source and the keyboard control (local operation). If the current command source is keyboard control, the function of this key is invalid.

2: Forward and reverse switching Use this key to switch the direction of the frequency command. This function is only valid when the command source is the command channel of the operation panel.

3: Forward jog (FJOG) can be achieved through this key.

4: Reverse jog (RJOG) can be realized through this key.

08-02	STOP/RESET key function	↗	Factory setting	1
	Setting range	0	Only in the keyboard operation mode, the STOP/RESET key stop function is effective	
		1	In any operation mode, the STOP/RESET key stop function is effective	

08-03	LED operation display parameter 1	↗	Factory setting	1F
	Setting range	0000~FFFF		
		Bit00	Running frequency1(Hz)	
		Bit01	Setting frequency(Hz)	
		Bit02	BUS Voltage(V)	
		Bit03	Output voltage(V)	
		Bit04	Output current(A)	
		Bit05	Output power(kW)	
		Bit06	Output torque(%)	
		Bit07	MI input status	
		Bit08	MO output status	
		Bit09	AVI1 voltage(V)	
		Bit10	AVI2/ACI voltage(V)	
		Bit11	Reserved	
		Bit12	Reserved	
		Bit13	Reserved	

08-03	LED operation display parameter 1	↗	Factory setting	1F
		Bit14	Load speed	
		Bit15	Reserved	
		If the above parameters need to be displayed during operation, set the corresponding position to 1, set the binary number to hexadecimal and set it to 08-03.		

08-04	LED operation display parameter 2	↗	Factory setting	0
		0000~FFFF		
		Bit00	Reserved	
		Bit01	Reserved	
		Bit02	Reserved	
		Bit03	Running frequency 2(Hz)	
		Bit04	Remaining running time	
		Bit05	AVI1 voltage Before correction(V)	
		Bit06	AVI2/ACI voltage Before correction(V)	
		Bit07	Reserved	
		Bit08	Reserved	
		Bit09	Current power-on time(Hour)	
		Bit10	Current running time(Min)	
		Bit11	Reserved	
		Bit12	Communication setting value	
		Bit13	Reserved	
		Bit14	Main frequency X display (Hz)	
		Bit15	Auxiliary frequency Y display (Hz)	
		If the above parameters need to be displayed during operation, set the corresponding position to 1, set the binary number to hexadecimal and set it to 08-04.		

Running display parameters are used to set the parameters that can be viewed when the inverter is in running state.

The maximum number of status parameters available for viewing is 32, and the status parameters to be displayed are selected according to the binary bits of the 08-03 and 08-04 parameter values. The display order starts from the lowest bit of 08-03.

08-05	LED shutdown display parameters	↗	Factory setting	33
		0000~FFFF		
		Bit00	Setting frequency(Hz)	
		Bit01	BUS voltage(V)	
		Bit02	MI input status	
		Bit03	MO output status	
		Bit04	AVI1 voltage(V)	
		Bit05	AVI2/ACI voltage(V)	
		Bit06	Reserved	
		Bit07	Reserved	
		Bit08	Reserved	
		Bit09	Reserved	
		Bit10	Load speed	

08-05	LED shutdown display parameters	↗	Factory setting	33
		Bit11	Reserved	
		Bit12	Reserved	
	If the above parameters need to be displayed during operation, set the corresponding position to 1, set the binary number to hexadecimal and set it to 08-05.			

08-06	Load speed display coefficient	↗	Factory setting	1.0000
	Setting range	0.0001~6.5000		

When the load speed Load speed needs to be displayed, this parameter is used to adjust the corresponding relationship between the inverter output frequency and the load speed Load speed. Refer to the instructions of 08-12.

08-08	Inverter module radiator temperature	Factory setting	-
	Setting range	0.0℃~100.0℃	

Displays the temperature of the inverter module IGBT.

Different types of inverter modules have different IGBT over-temperature protection values.

08-10	Software version No.	Factory setting	-
--------------	----------------------	-----------------	---

08-11	Cumulative running time	Factory setting	-
	Setting range	0h~65535h	

Cumulative running time of the inverter is displayed. When the running time reaches the set running time 09-17, the inverter's multi-function digital output function (12) outputs an ON signal.

08-12	Load speed display the number of decimal places	↗	Factory setting	21
	Setting range	Units: Number of decimal places for load speed Tens place: Number of decimal places for feedback speed		
		0	0 decimal place	
		1	1 decimal place	
		2	2 decimal places	
		3	3 decimal places	

Used to set the number of decimal places for load speed display. The following example illustrates the calculation method of load speed:

If the load speed display coefficient 08-06 is 2.000, the load speed decimal point number 08-12 is 2 (2 decimal points), when the inverter running frequency is 40.00Hz, the load speed is: $40.00 \times 2.000 = 80.00$ (2 decimal points display)

If the inverter is in a stopped state, the load speed is displayed as the speed corresponding to the setting frequency, that is, "set load speed". Taking the set frequency of 50.00Hz as an example, the load speed in the stop state is: $50.00 \times 2.000 = 100.00$ (2 decimal places display)

08-13	Cumulative power-on time	Factory setting	-
--------------	--------------------------	-----------------	---

Shows the cumulative power-on time of the inverter since the factory.

When this time reaches the set power-on time (09-17), the inverter's multi-function digital output function (24) outputs an ON signal.

08-14	Cumulative power consumption	Factory setting	-
	Setting range	0~65535 degree	

Displays the cumulative power consumption of the inverter so far.

09 Accessibility Parameters

09-00	Jog running frequency	↗	Factory setting	5.00Hz
	Setting range	0.00Hz~Max frequency		
09-01	Jog acceleration time	↗	Factory setting	20.0s
	Setting range	0.0s~6500.0s		
09-02	Jog deceleration time	↗	Factory setting	20.0s
	Setting range	0.0s~6500.0s		

Define the given frequency and acceleration/deceleration time of the inverter when jogging.

During jog operation, the start mode is fixed to the direct start mode (07-00=0), and the stop mode is fixed to the deceleration stop (07-05=0).

09-03	Acceleration time 2	↗	Factory setting	Type setting
09-04	Deceleration time 2	↗	Factory setting	Type setting
09-05	Acceleration time 3	↗	Factory setting	Type setting
09-06	Deceleration time 3	↗	Factory setting	Type setting
09-07	Acceleration time 4	↗	Factory setting	Type setting
09-08	Deceleration time 4	↗	Factory setting	Type setting
	Setting range	0.0s~6500.0s		

S3100L provides 4 groups of acceleration and deceleration time, respectively 00-07/00-08 and the above 3 groups of acceleration and deceleration time.

The definitions of the 4 groups of acceleration and deceleration times are exactly the same, please refer to the relevant descriptions of 00-07 and 00-08. Through different combinations of multi-function digital input terminals MI, you can switch to select 4 groups of acceleration and deceleration time. For specific usage, please refer to the relevant descriptions in parameters 04-00~04-05.

09-09	Jump frequency 1	↗	Factory setting	0.00Hz
	Setting range	0.00Hz~Max frequency		
09-10	Jump frequency 2	↗	Factory setting	0.00Hz
	Setting range	0.00Hz~Max frequency		
09-11	Jump frequency amplitude	↗	Factory setting	0.00Hz
	Setting range	0.00Hz~Max frequency		

When the set frequency is within the range of the jump frequency, the actual operating frequency will run at the jump frequency closer to the set frequency. By setting the jump frequency, the inverter can avoid the mechanical resonance point of the load.

The S3100L can set two jump frequency points. If both jump frequencies are set to 0, the jump frequency function is cancelled. Please refer to Figure 5-15 for the principle of jump frequency and jump frequency amplitude.

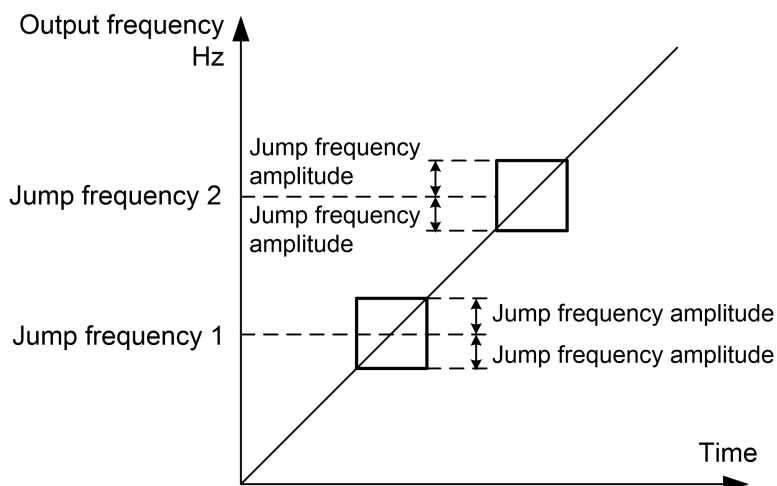

Figure 5-15 Schematic diagram of jumping frequency

09-12	Forward and reverse dead time	↗	Factory setting	0.0s
	Setting range	0.00s~3000.0s		

Set the transition time at the output 0Hz during the inverter forward and reverse transition, as shown in Figure 5-16:

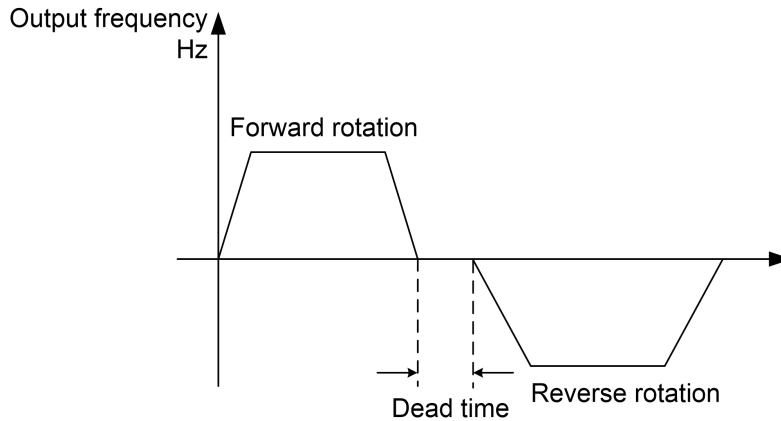

Figure 5-16 Schematic diagram of forward and reverse dead time

09-13	Reverse control enable	↗	Factory setting	0
	Setting range	0	Enabled	
		1	Disabled	

Use this parameter to set the inverter to set 09-13=1 when the motor is not allowed to reverse.

09-14	Operating mode with set frequency lower than lower limit frequency	↗	Factory setting	0
	Setting range	0	Run at the lower limit frequency	
		1	Downtime	
		2	Zero speed operation	

When the set frequency is lower than the lower limit frequency, the running state of the inverter can be selected by this parameter. S3100L provides three operating modes to meet various application requirements.

09-15	Drop control	↗	Factory setting	0.00Hz
	Setting range	0.00Hz~10.00Hz		

Refers to the output frequency drop value when the inverter is outputting the rated load. This function is generally used for load distribution when multiple motors drag the same load.

The droop control means that as the load increases, the output frequency of the inverter decreases, so that when multiple motors drag the same load, the output frequency of the motor in the load decreases more, which can reduce the load of the motor and realize the The load is even.

09-16	Set cumulative power-on arrival time	↗	Factory setting	0h
	Setting range	0h~65000h		

When the cumulative power-on time (08-13) reaches the power-on time set in 09-16, the inverter's multi-function output terminal Terminal (function 24) turns on.

09-17	Set cumulative running arrival time	↗	Factory setting	0h
	Setting range	0h~65000h		

Used to set the running time of the inverter.

When the accumulated running time (08-11) reaches this set running time, the inverter's multi-function output terminal Terminal (function 12) turns on.

09-18	Power-on operation protection options	↗	Factory setting	1
	Setting range	0	Run command is valid when power on	
		1	Run command is invalid when power on	

The parameter is 1, if the running command is valid when the inverter is powered on (such as the terminal running command is closed before powering on), the inverter does not respond to the running command, and the running command must be canceled once before the inverter is valid again response.

In addition, if this parameter is set to 1, if the running command is valid at the time of inverter fault reset, the inverter will not respond to the running command, and the running command must be removed before the running protection state can be eliminated.

Setting this parameter to 1 can prevent the danger caused by the motor responding to the running command when the power is turned on or the fault is reset without knowing it.

09-19	Frequency detection value(FDT1)	↗	Factory setting	50.00Hz
	Setting range	0.00Hz~Max frequency		
09-20	Frequency detection hysteresis(FDT1)	↗	Factory setting	5.0%
	Setting range	0.0%~100.0%(FDT1 Level)		

When the running frequency is greater than or equal to the frequency detection value, the inverter's multi-function output terminal (function 3) outputs an ON signal. When the frequency is lower than the detection value by a certain frequency value, the output ON signal is canceled.

The above parameters are used to set the detection value of the output frequency and the hysteresis value of the output operation release. Where 09-20 is the percentage of the hysteresis frequency relative to the frequency detection value 09-19. Figure 5-17 is a schematic diagram of the FDT function.

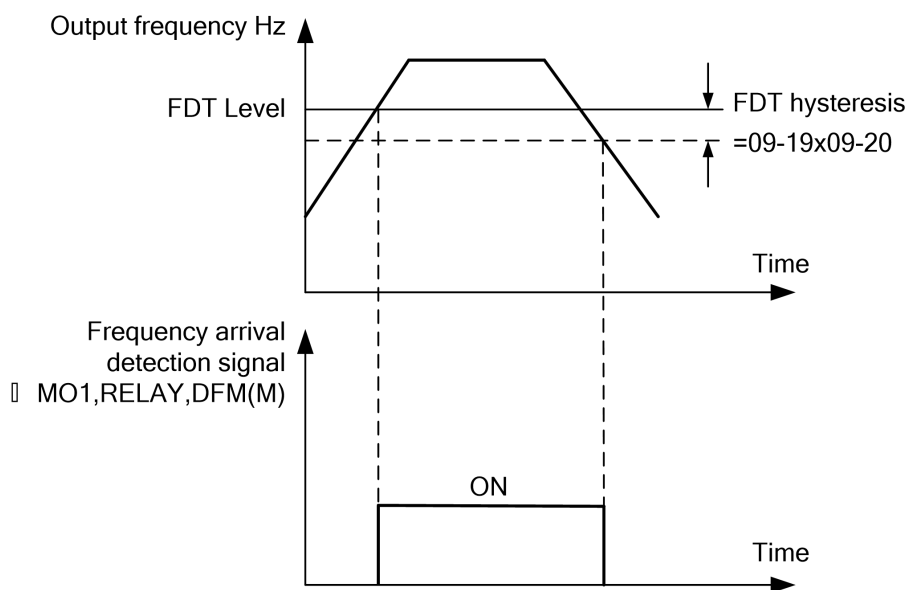

Figure 5-17 Schematic diagram of FDT level

09-21	Frequency reach detection width	↗	Factory setting	0.0%
	Setting range	0.00~100%(Max frequency)		

When the running frequency of the inverter is within a certain range of the target frequency, the multi-function output terminal (function 4) of the inverter outputs an ON signal.

This parameter is used to set the detection range of frequency arrival. This parameter is a percentage relative to the maximum frequency. Figure 5-18 is a schematic diagram of frequency arrival.

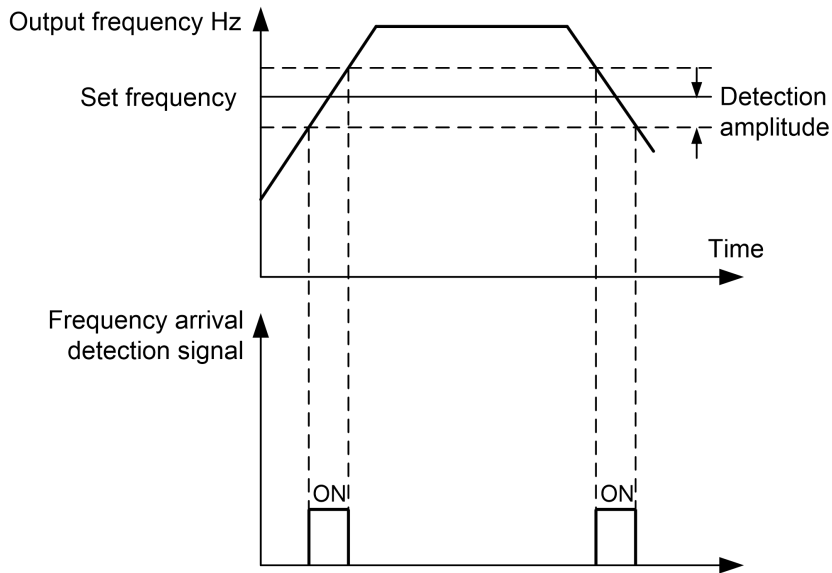

Figure 5-18 Schematic diagram of the frequency arrival detection amplitude

09-22	Whether the jump frequency is effective during acceleration and deceleration		↗	Factory setting	0
	Setting range	0	Invalid		
		1	Valid		

When the setting is valid, when the operating frequency is within the range of the skip frequency, the actual operating frequency will skip the boundary of the set skip frequency. As shown in Figure 5-19.

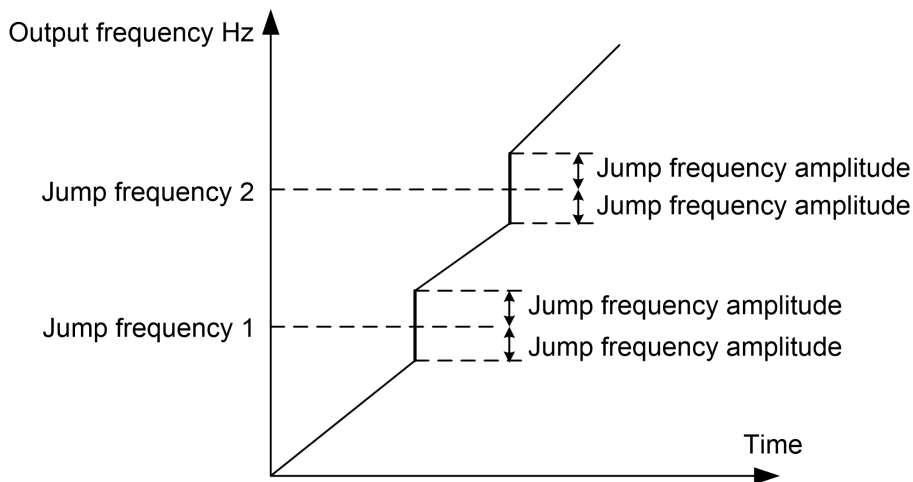

Figure 5-19 Effective schematic diagram of jump frequency during acceleration and deceleration

09-25	Switching frequency point between acceleration time 1 and acceleration time 2		↗	Factory setting	0.00Hz
	Setting range	0.00Hz~Max frequency			
09-26	Switching frequency point between deceleration time 1 and deceleration time 2		↗	Factory setting	0.00Hz
	Setting range	0.00Hz~Max frequency			

During the operation of the inverter, different acceleration and deceleration times can be selected according to the operating frequency range instead of the M1 terminal.

Figure 5-20 is a schematic diagram of acceleration/deceleration time switching. During acceleration, if the operating frequency is less than 09-25, select acceleration time 2; if the operating frequency is greater than 09-25, select acceleration time 1.

During deceleration, if the operating frequency is greater than 09-26, select deceleration time 1, if the operating frequency is less than 09-26, select deceleration time 2.

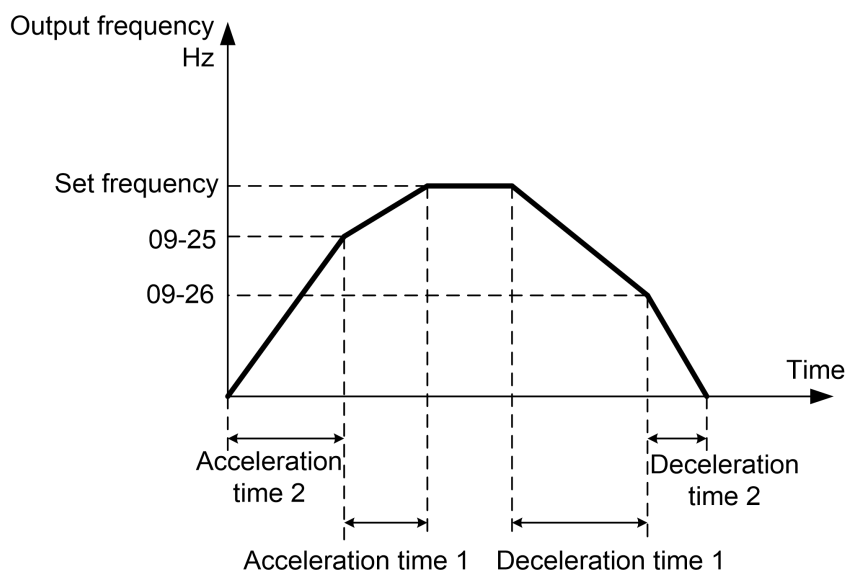

Figure 5-20 Acceleration and deceleration time switching diagram

09-27	Terminal jogging priority		↗	Factory setting	0
	Setting range	0	Invalid		
		1	Valid		

This parameter can set the priority of the terminal jog command to the highest.

When the terminal jog priority is effective, if the terminal jog command appears during the operation, the inverter will switch to the terminal jog running state.

09-28	Frequency detection value(FDT2)		↗	Factory setting	50.00Hz
	Setting range	0.00Hz~Max frequency			
09-29	Frequency detection hysteresis(FDT2)		↗	Factory setting	5.0%
	Setting range	0.0%~100.0%(FDT2 Level)			

The frequency detection function is exactly the same as the function of FDT1. Please refer to the relevant description of FDT1, namely the description of parameters 09-19 and 09-20.

09-30	Arbitrary arrival frequency detection value 1		↗	Factory setting	50.00Hz
	Setting range	0.00Hz~Max frequency			
09-31	Arbitrary arrival frequency detection width 1		↗	Factory setting	0.0%
	Setting range	0.0%~100.0%(Max frequency)			
09-32	Arbitrary arrival frequency detection value 2		↗	Factory setting	50.00Hz
	Setting range	0.00Hz~Max frequency			
09-33	Arbitrary arrival frequency detection width 2		↗	Factory setting	0.0%
	Setting range	0.0%~100.0%(Max frequency)			

When the output frequency is within the range of the positive and negative detection amplitude of any detected frequency, the multi-function output terminal (function 26/27) outputs an ON signal.

S3100L provides two sets of arbitrary arrival frequency detection parameters, set frequency value and frequency detection range respectively.

Figure 5-21 is a schematic diagram of this function.

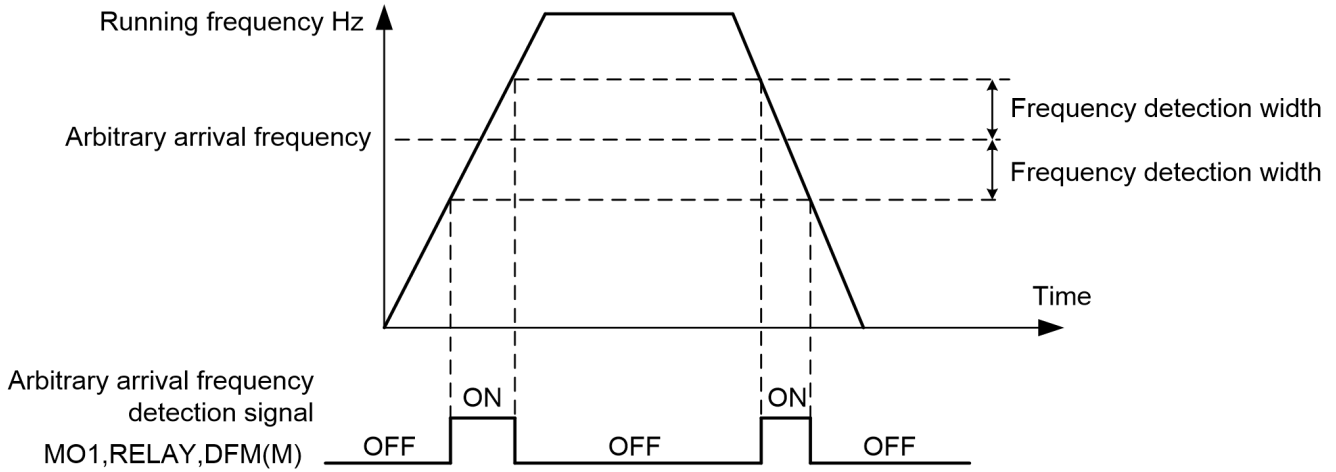

Figure 5-21 Schematic diagram of arbitrary arrival frequency detection

09-34	Zero current detection level	↗	Factory setting	5.0%
	Setting range	0.0%~300.0% (100.0% corresponds to the rated current of the motor)		
09-35	Zero current detection delay time	↗	Factory setting	0.10s
	Setting range	0.01s~600.00s		

When the output current of the inverter is less than or equal to the zero current detection level and the duration exceeds the zero signal current detection delay time, the multi-function output terminal (function 34) of the inverter outputs an ON signal. Figure 5-22 is a schematic diagram of zero current detection.

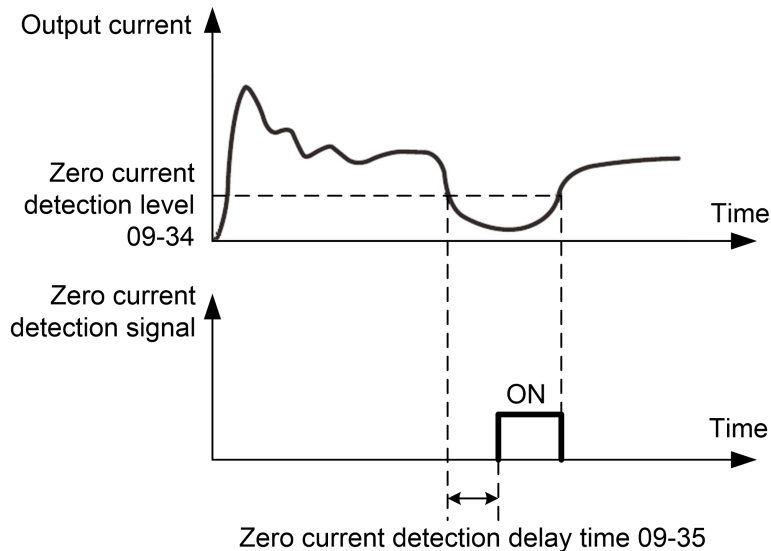

Figure 5-22 Schematic diagram of zero current detection

09-36	Output current limit	↗	Factory setting	200.0%
	Setting range	0.0%(No detection) 0.1%~300.0%(motor rated current)		
09-37	Output overcurrent detection delay time	↗	Factory setting	0.00s
	Setting range	0.00s~600.00s		

When the output current of the inverter is greater than or exceeds the limit detection point and the duration exceeds the software overcurrent detection delay time, the inverter's multi-function output terminal (function 36) outputs an ON signal.

Figure 5-23 is a schematic diagram of the output overcurrent detection.

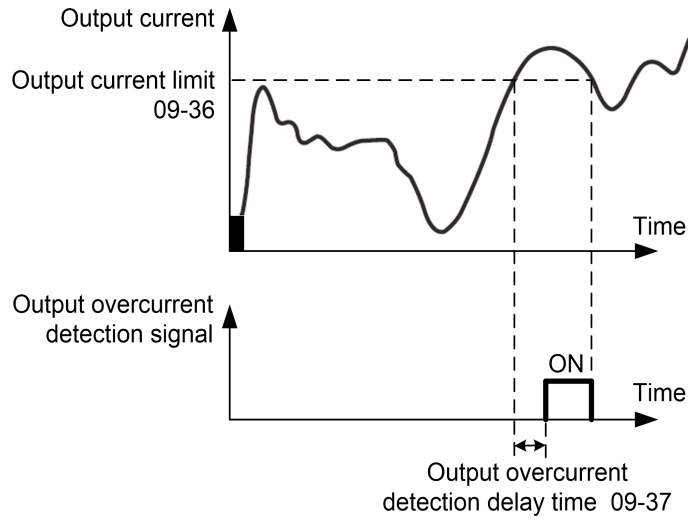

Figure 5-23 Schematic diagram of output overcurrent detection

09-38	Arbitrary arrival current 1		↗	Factory setting	100.0%
	Setting range	0.0%~300.0%(motor rated current)			
09-39	Arbitrary arrival current 1 width		↗	Factory setting	0.0%
	Setting range	0.0%~300.0%(motor rated current)			
09-40	Arbitrary arrival current 2		↗	Factory setting	100.0%
	Setting range	0.0%~300.0%(motor rated current)			
09-41	Arbitrary arrival current 2 width		↗	Factory setting	0.0%
	Setting range	0.0%~300.0%(motor rated current)			

When the inverter output current is within any positive or negative detection width of the current, the inverter multi-function output terminal Terminal (function 28/29) outputs ON signal.

S3100L provides two sets of arbitrary current arrival and detection width parameters. Figure 5-24 is a schematic diagram of the function.

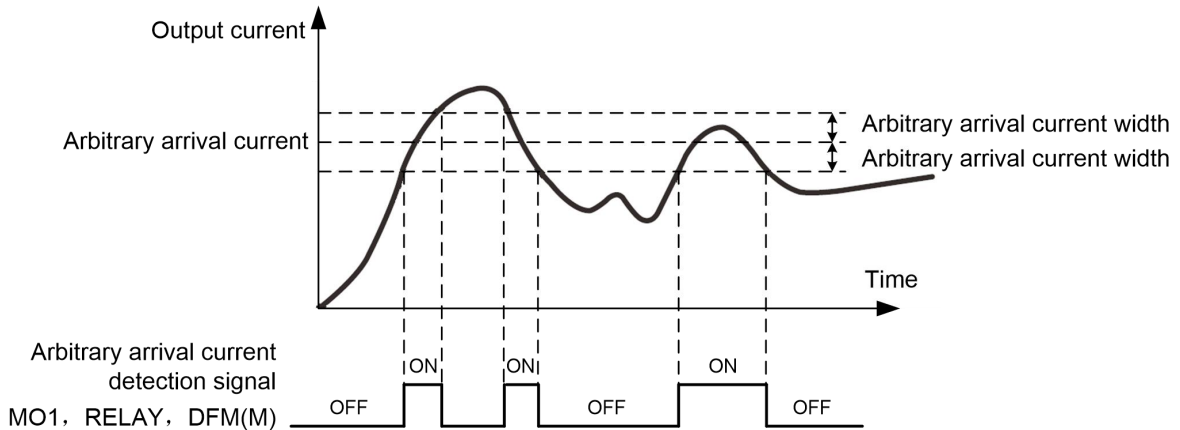

Figure 5-24 Schematic diagram of arbitrary arrival current detection

09-42	Timing function selection			Factory setting	0
	Setting range	0	Invalid		
		1	Valid		
09-43	Timed running time selection			Factory setting	0
	Setting range	0	09-44 Setting		
		1	AVI1		
		2	AVI2/ACI		
		3	Reserved		
		Analog input range 100% corresponds to 09-44			

09-44	Timed running time		Factory setting	0.0Min
	Setting range	0.0Min~6500.0Min		

09-42 when the timing function selection is valid, the inverter starts timing when it starts, and when the set timing operation time is reached, the inverter automatically stops, and the multi-function output terminal (function 30) outputs an ON signal.

Every time the inverter starts, it starts counting from 0, and the remaining running time can be checked through 99-20. The scheduled running time is set by 09-43 and 09-44, and the time unit is minutes.

09-45	Lower limit of AV11 input voltage protection value	↗	Factory setting	3.10V
	Setting range	0.00V~09-46		
09-46	Upper limit of AV11 input voltage protection value	↗	Factory setting	6.80V
	Setting range	09-45~11.00V		

When the value of the analog input AV11 is greater than 09-46, or the AV11 input is less than 09-45, the inverter's multi-function output terminal (function 31) outputs an ON signal, which is used to indicate whether the AV11 input voltage is within the set range.

09-47	Module temperature reached	↗	Factory setting	75℃
	Setting range	0℃~100℃		

When the temperature of the inverter radiator reaches this temperature, the multi-function output terminal (function 35) of the inverter outputs an ON signal.

09-48	Cooling fan control		Factory setting	0
	Setting range	0	Fans run during operation	
		1	The fan keeps running	

It is used to select the operation mode of the cooling fan. When it is set to 0, the fan runs in the running state. If the temperature of the radiator is higher than 40 degrees in the stopped state, the fan runs.

When selected as 1, the fan keeps running after power on.

09-49	Wake frequency	↗	Factory setting	0.00Hz
	Setting range	Sleep frequency (09-51) ~ max frequency (00-03)		
09-50	Wake delay time	↗	Factory setting	0.0s
	Setting range	0.0s~6500.0s		
09-51	Sleep frequency	↗	Factory setting	0.00Hz
	Setting range	0.00Hz~Wake frequency(09-49)		
09-52	Sleep delay time	↗	Factory setting	0.0s
	Setting range	0.0s~6500.0s		

This group of parameters is used to implement sleep and wake-up functions in water supply applications.

During the operation of the inverter, when the set frequency is less than or equal to the sleep frequency of 09-51, after the delay time of 09-52, the inverter enters the sleep state and automatically stops.

If the inverter is in sleep state and the current running command is valid, when the set frequency is greater than or equal to the wake-up frequency of 09-49, the inverter will start after a delay time of 09-50.

In general, please set the wake-up frequency to be greater than or equal to the sleep frequency. If the wake-up frequency and sleep frequency are both set to 0.00Hz, the sleep and wake-up functions are invalid.

When the sleep function is enabled, if the frequency source uses PID, whether the PID operation in the sleep state is affected by the parameter 10-28. At this time, it is necessary to select PID calculation when the machine is stopped (10-28=1).

09-53	Arrival time setting for this run	↗	Factory setting	0.0Min
	Setting range	0.0Min~6500.0Min		

When the running time of this startup reaches this time, the inverter multi-function output terminal Terminal (function 40) outputs ON signal.

11 Fault and Protection Parameters

11-00	Motor overload protection selection	↗	Factory setting	1
	Setting range	0	Disabled	
		1	Enabled	
11-01	Motor overload protection gain	↗	Factory setting	1.00
	Setting range	0.20~10.00		

0: No protection, no motor overload protection feature (use with caution), at this time, the inverter has no overload protection for the load motor.

1: At this time, the inverter judges whether the motor is overloaded according to the inverse time limit curve of the motor overload protection. The inverse time limit curve of motor overload protection is: $195\% \times (11-01) \times \text{motor rated current}$, which will alarm the motor overload fault for 1 minute; $150\% \times (11-01) \times \text{motor rated current}$, which lasts 5 minutes Then alarm motor overload.

The user sets the value of 11-01 according to the actual overload capacity of the motor. If the setting is too large, the motor may be damaged due to overheating and the inverter may not alarm in time!

11-02	Motor overload pre-warning coefficient	↗	Factory setting	80%
	Setting range	50%~100%		

This function is used to output an early warning signal to the control system through the multi-function output terminal before the motor overload protection. The early warning function can set how much early warning is given before the motor overload protection. The larger the value, the smaller the early warning advance.

When the cumulative output current of the inverter is greater than the product of the overload inverse time curve and 11-02, the inverter's multi-function output terminal (function 7) outputs the "motor overload pre-alarm" ON signal.

11-03	Power-on short circuit protection selection	↗	Factory setting	1
	Setting range	0	Invalid	
		1	Valid	

Select whether to detect the short circuit fault of the motor when the inverter is powered on.

If this function is valid, there will be voltage output from the UVW terminal of the inverter within a period of time after power-on.

11-09	Fault automatic reset times	↗	Factory setting	0
	Setting range	0~20		

When the inverter selects automatic fault reset, it is used to set the number of automatic resets. After this number of times, the inverter remains in a fault state and requires manual intervention.

11-10	Action selection of fault multi-function output terminal during fault automatic reset	↗	Factory setting	0
	Setting range	0	No action	
		1	Action	

If the inverter is equipped with a fault automatic reset function, whether the multi-function terminals are activated during the fault automatic reset can be set via 11-10.

11-11	Fault automatic reset interval time	↗	Factory setting	1.0s
	Setting range	0.1s~100.0s		

Waiting time from inverter fault alarm to automatic fault reset.

11-12	Input phase loss protection selection	↗	Factory setting	1
	Setting range	0	Disabled	
		1	Enabled	

Choose whether to protect the input phase loss.

S3100L 5.5kW~18.5kW It is equipped with input phase loss detection circuit.

11-13	Output phase loss protection selection	↗	Factory setting	1
	Setting range	0	Disabled	
		1	Enabled	

Choose whether to protect the output phase loss.

11-14	First failure type	Factory setting	-
11-15	Second failure type	Factory setting	-
11-16	Third (latest) fault type	Factory setting	-

Record the last three fault types of the inverter,0 is no fault. For the cause and solution of the fault, please refer to the relevant instructions in Chapter 6.

11-17	Frequency at the third failure	Frequency at latest failure																		
11-18	Current at the third fault	Current at latest fault																		
11-19	Bus voltage at the third fault	Bus voltage at the latest fault																		
11-20	Input terminal status at the third fault	The state of the digital input terminal during the latest failure, the order is:																		
		<table border="1"> <tr> <td>BIT9</td><td>BIT8</td><td>BIT7</td><td>BIT6</td><td>BIT5</td><td>BIT4</td><td>BIT3</td><td>BIT2</td><td>BIT1</td><td>BIT0</td> </tr> <tr> <td>MI0</td><td>MI9</td><td>MI8</td><td>MI7</td><td>MI6</td><td>MI5</td><td>MI4</td><td>MI3</td><td>MI2</td><td>MI1</td> </tr> </table> <p>When the input terminal is ON, the corresponding secondary system bit is 1, OFF is 0, and all MI status is converted to decimal number display.</p>	BIT9	BIT8	BIT7	BIT6	BIT5	BIT4	BIT3	BIT2	BIT1	BIT0	MI0	MI9	MI8	MI7	MI6	MI5	MI4	MI3
BIT9	BIT8	BIT7	BIT6	BIT5	BIT4	BIT3	BIT2	BIT1	BIT0											
MI0	MI9	MI8	MI7	MI6	MI5	MI4	MI3	MI2	MI1											
11-21	Output terminal status at the third fault	The state of all output terminals during the latest fault,the order is																		
		<table border="1"> <tr> <td>BIT4</td><td>BIT3</td><td>BIT2</td><td>BIT1</td><td>BIT0</td> </tr> <tr> <td>MO2</td><td>MO1</td><td>REL2</td><td>REL1</td><td>DFM(P)</td> </tr> </table> <p>When the input terminal is ON, the corresponding secondary system bit is 1, OFF is 0, and all MI status is converted to decimal number display.</p>	BIT4	BIT3	BIT2	BIT1	BIT0	MO2	MO1	REL2	REL1	DFM(P)								
BIT4	BIT3	BIT2	BIT1	BIT0																
MO2	MO1	REL2	REL1	DFM(P)																
11-22	Inverter status at the third fault	Reserved																		
11-23	Power-on time at the third fault	The current power-on time when the latest fault occurred																		
11-24	Running time at the third failure	Current running time at the time of the latest failure																		
11-27	Frequency at second failure	The same to 11-17~11-24																		
11-28	Current at second fault																			
11-29	Bus voltage at the second fault																			
11-30	Input terminal status at the second fault																			
11-31	Output terminal status at the second fault																			
11-32	Inverter status at the second fault																			

11-33	Power-on time at the second fault	
11-34	Running time on second failure	
11-37	Frequency at first failure	
11-38	Current at first fault	
11-39	Bus voltage at first fault	
11-40	Input terminal status at the first fault	The same to 11-17~11-24
11-41	Output terminal status at the first fault	
11-42	Inverter status at first fault	
11-43	Power-on time at first failure	
11-44	Operating time at first failure	

11-47	Fault protection action selection 1		↗	Factory setting	0
	Setting range	Single digit	Motor overload(OL1)		
		0	Coast to stop		
		1	Stop according to the stop mode		
		2	Continue to run		
		Tens digital	Input phase loss(SPI)(Same bit)		
		Hundreds digital	Output phase loss(SPo)(Same bit)		
		Thousands digital	External fault(EF)(Same bit)		
		Ten thousands digital	Communication error(CE)(Same bit)		
11-48	Fault protection action selection 2		↗	Factory setting	0
	Setting range	Single digit	Reserved		
		Tens digital	EEPROM read write fault(EEP)		
		0	Coast to stop		
		1	Stop according to the stop mode		
		Hundreds digital	Reserved		
		Thousands digital	Reserved		
		Ten thousands digital	Operating time arrival (Eond) (same as 11-47 digits)		
11-49	Fault protection action selection 3		↗	Factory setting	0
	Setting range	Single digit	Reserved		
		Tens digital	Reserved		
		Hundreds digital	Power-on time arrival (EIND) (same as 11-47 digits)		
		Thousands digital	Lost load(oLL)		
		0	Coast to stop		
		1	Stop according to the stop mode		
		2	Decelerate to 7% of the rated frequency of the motor and continue to run. If the load is not lost, it will automatically return to the set frequency.		
		Ten thousands digital	Reserved		

11-50	Fault protection action selection 4	↗	Factory setting	
	Setting range	Reserved		

When "free stop" is selected, the inverter displays the fault code and directly stops.

When "Stop by Stop Mode" is selected: The inverter displays a fault and stops according to the stop mode.

When "Continue running" is selected: The inverter displays a fault and the running frequency continues to run at the selected frequency of 11-54.

11-54	Continue running frequency selection in case of failure	↗	Factory setting	0
	Setting range	0	Run at current operating frequency	
		1	Run at set frequency	
		2	Run at upper limit frequency	
		3	Run at the lower limit frequency	
		4	Run at abnormal standby frequency	
11-55	Abnormal standby frequency	↗	Factory setting	100.0%
	Setting range	0.0%~100.0%(100.0% corresponds to the maximum frequency 00-03)		

When a fault occurs during the operation of the inverter, and the processing method of the fault is set to continue running, the inverter displays the fault and continues to run at the selected frequency of 11-54. When the abnormal standby frequency is selected for operation, the value set in 11-55 is a percentage relative to the maximum frequency.

11-59	Instantaneous power failure action selection	↗	Factory setting	0
	Setting range	0	Invalid	
		1	Deceleration	
		2	Decelerate to stop	
11-60	Instantaneous power failure action pause judgment voltage	↗	Factory setting	85%
	Setting range	80~100%		
11-61	Judgment time of instantaneous power failure voltage rise	↗	Factory setting	0.5s
	Setting range	0.0s~100.0s		
11-62	Judgment voltage of instantaneous power failure	↗	Factory setting	80%
	Setting range	60%~100%(Standard bus Voltage)		

Refers to the moment when there is a power failure or the voltage drops suddenly, the inverter reduces the output speed, so that the load feedback energy maintains the inverter DC bus voltage, so that the inverter continues to run.

If 11-59=1, the inverter decelerates when there is an instantaneous power failure or a sudden drop in voltage, and when the bus voltage returns to normal, the inverter normally accelerates to the set frequency. The basis for judging the return of the bus voltage to normal is that the bus voltage is normal and the duration exceeds the set time of 11-61.

If 11-59=2, during an instantaneous power failure or a sudden drop in voltage, the inverter decelerates until it stops.

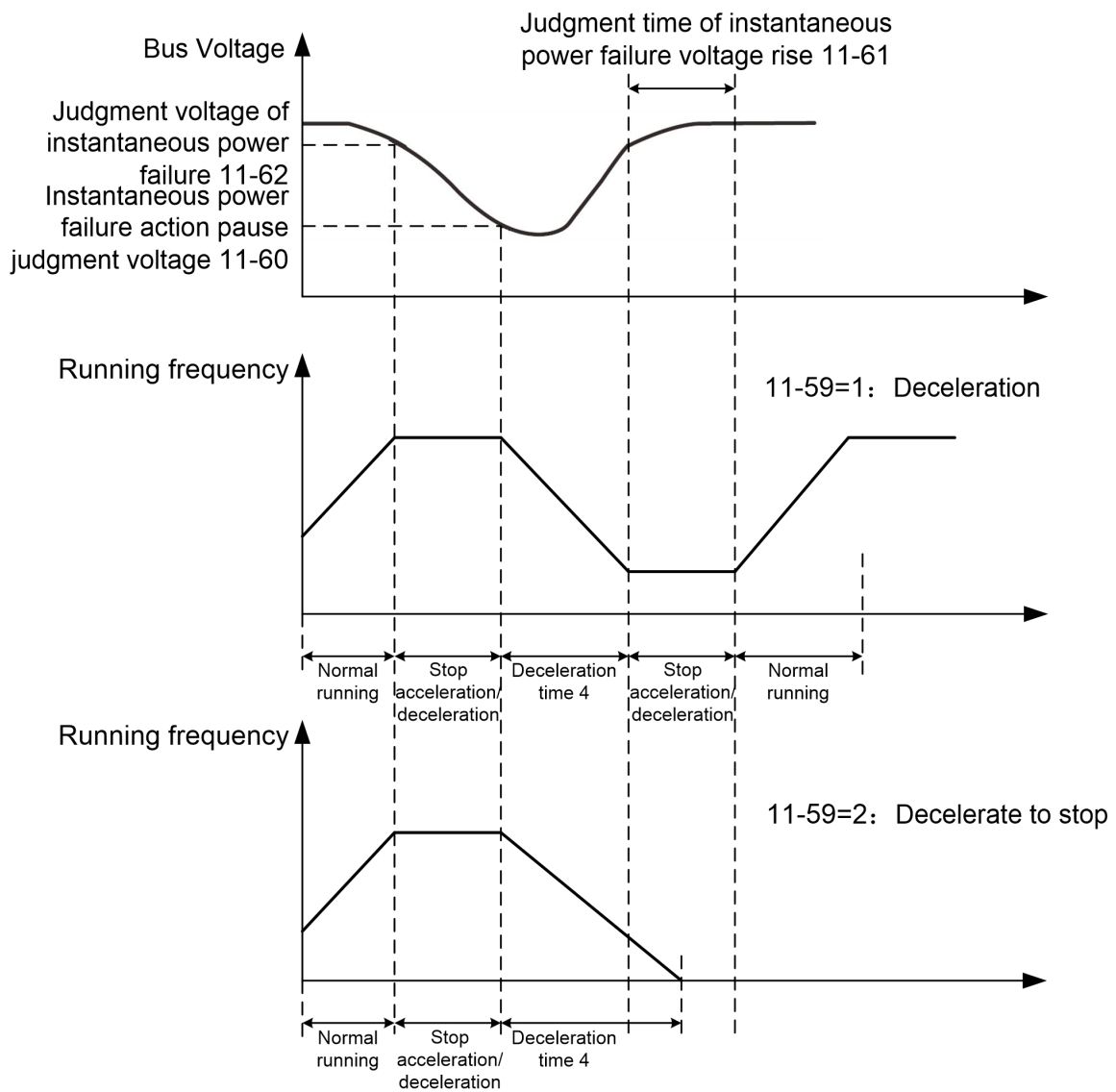

Figure 5-28 Schematic diagram of instantaneous power failure

11-63	Lost load protection options		↗	Factory setting	0
	Setting range	0	Invalid		
		1	Valid		
11-64	Lost load detection level		↗	Factory setting	10.0%
	Setting range	0.0~100.0%			
11-65	Lost load detection time		↗	Factory setting	1.0s
	Setting range	0.0s~60.0s			

If the off-load protection function is effective, when the inverter output current is less than the off-load detection level 11-64, and the duration is greater than the off-load detection time 11-65, the inverter output frequency is automatically reduced to 7% of the rated frequency. During the load protection period, if the load is restored, the inverter automatically resumes to run at the set frequency.

11-67	Over speed detection range			Factory setting	20.0%
	Setting range	0.0~100.0%			
11-68	Over speed detection time			Factory setting	0.010s
	Setting range	0.001s~6.000s			
11-69	Over speed detection time			Factory setting	20.0%
	Setting range	0.0~100.0%			

11-70	Speed deviation detection time		Factory setting	5.0s
	Setting range	0.0s~60.0s		

11-67 overspeed detection amplitude refers to the amplitude of abnormal speed exceeding the upper frequency limit.

11-69 speed deviation detection, 100% corresponds to the maximum frequency value of 00-03. When the speed is abnormal and the duration reaches the set time, a speed abnormality fault is reported.

12 Serial Communication Parameters

12-00	Local address		Factory setting	1
	Setting range	1~247, 0 is broadcast address		

When the local address is set to 0, it is the broadcast address to realize the broadcast function of the host computer.

The local address is unique (except broadcast address), which is the basis for the point-to-point communication between the host computer and the inverter.

12-01	Baud rate		Factory setting	0005
	Setting range	Single digit	MODUBS Baud rate	
		0	300BPS	
		1	600BPS	
		2	1200BPS	
		3	2400BPS	
		4	4800BPS	
		5	9600BPS	
		6	19200BPS	
		7	38400BPS	
		8	57600BPS	
	9	115200BPS		

This parameter is used to set the data transmission rate between the host computer and the inverter. Note that the baud rate set by the host computer and the inverter must be the same; otherwise, communication cannot be performed. The higher the baud rate, the faster the communication speed.

12-02	Data format		Factory setting	0
	Setting range	0	No checking(8-N-1)	
		1	Even parity checking(8-E-1)	
		2	Odd parity checking(8-O-1)	
		3	No checking(8-N-2)	

The host computer must coincide with the data format set by inverter, or communication can't be operated.

12-03	Communication response delay		Factory setting	2
	Setting range	0~20ms		

Communication response delay refers to the interval time from end of inverter data receiving to sending response data to host computer. If the response delay time is shorter than system processing time, the response delay is subject to system processing time. If the response delay time is longer than system processing time, the system has to delay after processing the data. And send data to the host computer until the delay time is reached.

12-04	Communication timeout	↗	Factory setting	0.0
	Setting range	0.0(invalid),0.1~60.0s		

When this function code is set as 0.0s, the parameter of communication overtime time is invalid.

When this function code is set as valid value, if the interval time between one communication and the next communication exceeds the time of communication overtime, the system will report communication error (CE).

Normally, this parameter is set as invalid value.setting this parameter in system of continuous communication can monitor the communication status.

12-06	Communication reading current resolution	↗	Factory setting	0
	Setting range	0	0.01A	
		1	0.1A	

It is used to determine the output unit of the current value when the communication reads the output current.

Modbus protocol

S3100L series inverters provide RS485 communication interface and support Modbus communication protocol. Users can realize centralized control through PC or PLC, set inverter running command, operating frequency, modify or read function code parameters, monitor inverter working status and fault information, etc.

Protocol content

The serial communication protocol defines the content and format of information transmitted in serial communication. These include: host polling and broadcasting; host encoding methods, including: function codes that require actions, transmission data, and error checking. The response of the slave also adopts the same structure, including: action confirmation, return data and error check. If the slave receives an error when receiving information, or cannot complete the action required by the master, it will organize a fault message as a response to the master.

Application method:

The frequency inverter can be connected to the "single master and multiple slave" control network with RS485 bus.

Bus structure:

(1) Interface method

RS485 hardware interface

(2) Transmission method

Asynchronous serial, half-duplex transmission mode.At the same time, only one master and slave can send data and the other can only receive data. In the process of serial asynchronous communication, data is sent frame by frame in the form of messages.

(3) Topology

Single-master multi-slave system.The setting range of the slave address is 1~247, and 0 is the broadcast communication address. The slave addresses in the network are all unique.

Protocol description:

The S3100L series inverter communication protocol is an asynchronous serial master-slave Modbus communication protocol. Only one device (host) in the network can establish the protocol (called "query/command"). Other devices (slave) can only respond to the "query/command" of the host by providing data, or make corresponding actions according to the "query/command" of the host.

The master here refers to a personal computer (PC), industrial control equipment or programmable logic controller (PLC), etc., and the slave refers to the S3100L inverter.

The master can not only communicate with a certain slave, but also broadcast information to all slaves. For the "query/command" of the separately accessed host, the slave must return a message (called a response). For the broadcast information sent by the host, the slave does not need to respond to the host.

Communication Frames Structure:

The Modbus protocol communication data format of S3100L series inverters uses RTU mode, and new frames always start with a silent transmission time of at least 3.5 bytes. On a network that calculates the transmission rate in baud rate, the transmission time of 3.5 bytes can be easily grasped. The data fields transmitted next are in

order: slave address, operation command code, data and CRC check word, each field transmission byte is hexadecimal 0.9, A.F. Network equipment always monitors the activity of the communication bus. When receiving the first field (address information), each network device confirms the byte. As the transmission of the last byte is completed, there is a similar 3.5-byte transmission time interval, which is used to indicate the end of this frame. After that, a new frame transmission will start.

A message frame must be transmitted as a continuous data stream. If there is a pause time of more than 1.5 characters before the frame is completed, the receiving device will refresh the incomplete message and assume that the next byte is the address field of a new message. Similarly, if a new message starts after the previous message in less than 3.5 characters, the receiving device will consider it as a continuation of the previous message. This will cause an error because the value in the last CRC field cannot be correct.

RTU Frame format:

Frame header (START)	3.5 character time
Slave address (ADR)	Communication address:1~247
Command code (CMD)	03: Read slave parameters; 06: Write slave parameters
DATA(N-1)	Data content: Function code parameter address, function code parameter number, function code parameter value, etc.
DATA(N-2)	
.....	
DATA 0	
CRC CHK upper bite	Detection value: CRC value
CRC CHK lower bite	
END	3.5 character time

Command code and communication data description:

Command code: 03H, read N words (Word can read up to 12 words)

For example: the start address 0002 of the inverter with slave address 01 is continuously reading two consecutive values.

RTU host command information

ADR	01H
CMD	03H
Start address upper bit	00H
Start address lower bit	02H
Date number upper bit	00H
Date number lower bit	02H
CRC CHK lower bit	CRC CHK
CRC CHK upper bit	

RTU slave response information

ADR	01H
CMD	03H
Byte number	04H
Date address 0002H upper bit	00H
Date address 0002H lower bit	00H
Date address 0003H upper bit	00H
Date address 0003H lower bit	01H
CRC CHK Lower bit	CRC CHK
CRC CHK Upper bit	

Command code: 06H Write a word (Word)

For example: write 5000 (1388H) to the slave address 02H inverter 0003H address

Host command information

ADR	02H
CMD	06H
Data address upper bit	00H
Data address lower bit	03H
Data content upper bit	13H
Data content lower bit	88H
CRC CHK lower bit	CRC CHK
CRC CHK upper bit	

Slave response information

ADR	02H
CMD	06H
Data address upper bit	00H
Data address lower bit	03H
Data content upper bit	13H
Data content lower bit	88H
CRC CHK lower bit	CRC CHK
CRC CHK upper bit	

Checking method—CRC checking method:

In RTU frame format, the frame includes frame incorrect test field based on CRC computing. The CRC field detects the content of whole frames. The CRC field is 2 bytes and includes 16-bit binary. It is added to frame after being computed by transmission equipment. The receiving equipment recalculates the CRC which has received frames and compare it with values in the received CRC field. If the two CRC values are different, it indicates that there is transmission error received.

In CRC checking mode, it saves in 0xFFFF first, then uses a procedure and processes the continuous 8 more than bytes in frames together with current register. Only the 8-bit data in every character is available to CRC, the start bit, end bit and parity checking are all unavailable to it.

In CRC production course, every 8-bit character is different from the register content separately or (XOR). The result moves to the direction of lowest effective bit. And the highest bit is filled with 0. LSB is picked up to test. If LSB is 1, the register is different from the preset value alone. If LSB is 0, no actions. The whole process must be repeated 8 times. As the last bit (8th bit) is finished, the next 8-bit character is different from the present value of register again. The final value in register is the CRC value after all bytes in frame have been executed.

Here is a simple function of CRC algorithm for users' reference.

```
unsigned int crc_cal_value(unsigned char *data_value, unsigned char data_length)
{
    int i;
    unsigned int crc_value=0xffff;
    while(data_length-->0)
    {
        crc_value^=*data_value++;
        for(i=0;i<8;i++)
        {
            if(crc_value&0x0001)
                crc_value=(crc_value>>1)^0xa001;
            else
                crc_value=crc_value>>1;
        }
    }
    return(crc_value);
}
```

Definition of communication data address

It is the definition of communication data address, which is used to control inverter operation, obtain the state information and relative function parameters.

(1) Using method of function code parameter address

Using numbers of function code as parameters to correspond to the register address, which has to be converted to hexadecimal system. For example, the number of 05-10, the function code address expressed by hexadecimal system is 050A.

Ranges of high and low characters: high-bit character-00~0FH; low-bit character--00~FFH. (The parameter's change attribute refers to the parameter description)

In addition, the frequent storage of EEPROM will reduce its service life. For users, some function codes don't need to be stored in communication mode. The application requirement can be met only through altering values in RAM. This function can be realized as long as changing the highest bit of corresponding function code address from 0 to 1. For example, function code 00-06 isn't stored into EEPROM, just alter the value in RAM and set the address as 8006H. This address is used only when write RAM, which can't be used as read function, otherwise, it is an unavailable address.

Note: For communication addresses with 15 or more parameters, add a 4200H offset. For example, 22-06 corresponds to 1606H + 4200H = 5806H.

(2)Communication command address:

Function description	Address definition	Description of data meaning	R/W characteristic
Communication control command	1000H	0001H:Forward running	W/R
		0002H:Reverse running	
		0003H:Forward jog	
		0004H:Reverse jog	
		0005H:Stop	
		0006H:Coast to stop	
		0007H:Fault reset	
		0008H:Reserved	
Inverter status	1001H	0001H:Forward running	R
		0002H:Reverse running	
		0003H:Inverter standby	
Communication setting value address	2000H	Communication setting value:range (-10000~10000) Note: Communication setting value is the percentage of relative value,10000 corresponds to 100.00%, and -10000 corresponds to -100.00%.For frequency dimension data, the percentage is the percentage of relative maximum frequency (00-03); for torque dimension data, the percentage is 02-07 (torque upper limit digital setting). About the PID feedback source, this percentage directly represents the value of the setting source.	W/R
Digital output terminal control	2001H	BIT0:MO1 output control BIT1:Reserved BIT2: Relay RA-RB-RC output control BIT3:Reserved BIT4:DFM(M) output control	W/R
Analog AFM output control	2002H	0~7FFFmeans 0%~100%	W/R
Address description of start/stop parameters	3000H	Running frequency	R
	3001H	Setting frequency	R
	3002H	Bus voltage	R
	3003H	Output voltage	R
	3004H	Output current	R
	3005H	Operation rotating speed	R
	3006H	Output power	R
	3007H	Output torque	R
	300AH	Terminal input flag state	R
	300BH	Terminal output flag state	R
	300CH	Analog quantity AVI1 value	R
	300DH	Analog quantity AVI2/ACI value	R
	300EH	Reserved	R
	3011H	Load speed	R
	3012H	Multi-speed	R
	3014H	Communication setting value	R
	3015H	Reserved	R
3016H	Main frequency X display	R	
3017H	Auxiliary frequency Y display	R	

Function description	Address definition	Description of data meaning	R/W characteristic
Inverter fault address	5000H	Fault information code coincides with number of fault type in function code menu. But the data here returned to the host is in hexadecimal system and not fault character.	R

Description: Data read from 5000H compares with the actual fault as shown in the table below.

Inverter fault address	Description Inverter fault information description	
5000H	0000:No fault	0015:EEPROM read write error
	0001:Short-circuit protection	0016:Inverter hardware fault
	0002:Acceleration over current	0017:Motor short circuit to ground
	0003:Deceleration over current	0018:Reserved
	0004:Constant speed over current	0019:Reserved
	0005:Acceleration overvoltage	001A:Running time arrival
	0006:Deceleration overvoltage	001B:Reserved
	0007:Constant speed overvoltage	001C:Reserved
	0008:Reserved	001D:Power-on time arrival
	0009:Bus undervoltage fault	001E:Load failure
	000A:Inverter overload	001F:The PID feedback disconnected
	000B:Motor overload	0028:Wave-by-wave current limiting fault
	000C:Input phase loss	0029:Switching motor fault during operation
	000D:Output phase loss	002A: Excessive speed deviation
	000E:Module overheat	002B:Motor over speed
	000F:External fault	002D:Motor over temperature
	0010:Communication error	005A: Encoder wire number setting error
	0011:Contactor fault	005b: Encoder not connected
0012:Current detection fault	005C: Initial position error	
0013:Motor self-learning error	005E: Speed feedback error	
0014:Reserved		

Communication error message response:

When a communication frame is detected as an error, the slave responds with a one-byte error code that defines the cause of the error. After the main device application receives an error code response, the typical process is to resend the message or make a command change for the corresponding error.

Communication error code definition:

Communication error home address	Wrong code definition
5001H	0000:No fault
	0001:Password error
	0002:Command code error
	0003:CRC checking error
	0004:Invalid address
	0005:Invalid parameters
	0006:Parameter change invalid
	0007:System locked
0008:Being EEPROM operation	

17 Torque Control Parameters

17-00	Speed/torque control method selection		Factory setting	0
	Setting range	0	Speed control	
		1	Torque control	

Select the control method of the inverter.

The S3100L's multi-function input M I terminal has two functions related to torque control: torque control prohibition (function 29) and speed control/torque control switching (function 46). These two terminals should be used in conjunction with 17-00 to achieve the switching between speed and torque control.

When the speed control/torque control switching terminal is invalid, the control mode is determined by 17-00. If the speed control/torque control switching is effective, the control mode is equivalent to the reverse of the value of 17-00.

When the torque control inhibit terminal is valid, the inverter is fixed to speed control mode.

17-01	Torque setting source selection in torque control mode		Factory setting	0	
	Setting range	0	Digital setting(17-03)		
		1	AVI1		
		2	AVI2/ACI		
		3	Reserved		
		4	Reserved		
		5	Communication setting		
		6	MIN(AVI1, AVI2/ACI)		
		7	MAX(AVI1, AVI2/ACI)		
	1-7 option full scale, corresponding to 17-03 digital setting				
17-03	Torque digital setting in torque control mode		↗	Factory setting	150.0%
	Setting range	-200.0%~200.0%			

Used to select the torque setting source.

The torque setting adopts a relative value, and 100.0% corresponds to the rated torque of the inverter. Setting range-200.0%~200.0%, indicating that the maximum torque of the inverter is 2 times the rated torque of the inverter.

When the torque setting source is selected from 1 to 7, 100% of communication, analog input, and pulse input correspond to 17-03.

17-05	Torque control forward maximum frequency		↗	Factory setting	50.00Hz
	Setting range	0.00Hz~Max frequency (00-03)			
17-06	Torque control reverse maximum frequency		↗	Factory setting	50.00Hz
	Setting range	0.00Hz~Max frequency (00-03)			

It is used to set the maximum running frequency of inverter forward or reverse in torque control mode.

When the inverter torque control, if the load torque is less than the motor output torque, it will continue to rise, in order to prevent accidents such as speeding of the mechanical system, the maximum speed of the motor during torque control must be limited.

17-07	Torque control acceleration time		↗	Factory setting	0.00s
	Setting range	0.00s~65000s			
17-08	Torque control Deceleration time		↗	Factory setting	0.00s
	Setting range	0.00s~65000s			

In the torque control mode, the difference between the motor output torque and the load torque determines the speed change rate of the motor and the load, so the motor speed may change rapidly, causing problems such as excessive noise or mechanical stress. By setting the torque control acceleration and deceleration time, the motor speed can be changed gently.

However, when quick torque response is required, the torque control acceleration/deceleration time needs to be set to 0.00s. For example, two motors are connected by a hard connection to drive the same load. In order to ensure that the load is evenly distributed, one inverter is set as the master to adopt the speed control mode, the other inverter is the slave and uses torque control, the actual output torque of the master As the torque command of the slave, the torque of the slave needs to quickly follow the master at this time, then the acceleration and deceleration time of the torque control of the slave is 0.00s.

22 Control Optimization Parameters

22-00	DPWM switching upper limit frequency	↗	Factory setting	8.00Hz
	Setting range	5.00Hz~Maximum operating frequency		

Only valid for V/f control. When the V/f is running, the wave transmission mode is lower than this value for the 7-segment continuous modulation mode, and the opposite is the 5-segment intermittent modulation mode.

In the 7-segment continuous modulation, the switching loss of the inverter is large, but the current ripple is small; in the 5-step intermittent debugging mode, the switching loss is small and the current ripple is large; but it may cause the motor at high frequency The instability of operation generally does not require modification.

For the V/f operation instability, please refer to parameter 03-11, for inverter loss and temperature rise, please refer to parameter 00-10;

22-02	Dead zone compensation mode selection	↗	Factory setting	1
	Setting range	0	No compensation	
		1	Compensation mode 1	

This parameter generally does not need to be modified. Only when there are special requirements on the quality of the output voltage waveform, or when the motor exhibits abnormalities such as oscillation, it is necessary to try to switch between different compensation modes. It is recommended to use compensation mode 2 for high power.

22-03	Random PWM depth	↗	Factory setting	0
	Setting range	0	Random PWM is invalid	
		1~10	Random depth of PWM carrier frequency	

Setting random PWM can make the monotonous harsh motor sound softer, and can help reduce external electromagnetic interference. When the random PWM depth is set to 0, random PWM is invalid. Adjust the random PWM to different depths to get different effects.

22-04	Fast current limit enable	↗	Factory setting	1
	Setting range	0	No enabling	
		1	Enabling	

Enabling the fast current limit function can minimize the overcurrent fault of the inverter and ensure the continuous operation of the inverter. If the inverter continues to be in the fast current limiting state for a long time, the inverter may be damaged due to overheating, etc. This situation is not allowed.

Therefore, the inverter is used in the occasion of large current impact for a long time, please select 1, the rapid current limit will alarm the fault CBC after a period of time, indicating that the inverter is overloaded and needs to be stopped.

22-05	Current detection compensation	↗	Factory setting	105
	Setting range	100~110		

It is used to set the current detection compensation of the inverter. If the setting is too large, the control performance may be reduced. Generally no modification is required.

22-06	Undervoltage level	↗	Factory setting	220V:200V 380V:350V
	Setting range	DC200V-DC420V		

It is used to set the voltage value of the undervoltage fault UV of the inverter. 100.0% of the inverters with different voltage levels correspond to different voltage points, respectively:

Single-phase 220V or three-phase 220V: DC200V

Three-phase 380V: DC350V

22-09	Overtoltage level		Factory setting	220V:400V 380V:820V
	Setting range	DC200V-DC820V		

24 Auxiliary function parameters 1

24-04	S curve start time ratio 2	↗	Factory setting	30.0%
	Setting range	0.0%~(100.0%-24-05)		
24-05	S curve end time ratio 2	↗	Factory setting	30.0%
	Setting range	0.0%~(100.0%-24-04)		

Parameters 24-04 and 24-05 define the start and end time ratios of the S-curve acceleration/deceleration, respectively. The two parameters must satisfy: $24-04 + 24-05 \leq 100.0\%$. See Figures 5-13 and 5-14 for details.

24-06	S curve start time ratio 3	↗	Factory setting	30.0%
	Setting range	0.0%~(100.0%-24-07)		
24-07	S curve end time ratio 3	↗	Factory setting	30.0%
	Setting range	0.0%~(100.0%-24-06)		

Parameters 24-06 and 24-07 define the start and end time ratios of the S-curve acceleration/deceleration, respectively. The two parameters must satisfy: $24-06 + 24-07 \leq 100.0\%$. See Figures 5-13 and 5-14 for details.

24-08	S curve start time ratio 4	↗	Factory setting	30.0%
	Setting range	0.0%~(100.0%-24-09)		
24-09	S curve end time ratio 4	↗	Factory setting	30.0%
	Setting range	0.0%~(100.0%-24-08)		

Parameters 24-08 and 24-09 define the start and end time ratios of the S-curve acceleration/deceleration, respectively. The two parameters must satisfy: $24-08 + 24-09 \leq 100.0\%$. See Figures 5-13 and 5-14 for details.

26 Specific parameters

26-00	Pre-torque coefficient 1		Factory setting	0.0%
	Setting range	0.0%~150.0%		
26-26	Pre-torque coefficient		Factory setting	0.0%
	Setting range	0.0%~150.0%		

When the tens digit of 26-27 is 0, 26-00 activates the pre-torque coefficient for downing, and 26-26 activates it for uping. When the tens digit is 1, 26-00 activates the pre-torque coefficient for negative cab displacement, and 26-26 activates it for positive displacement.

26-01	Pre-torque bias		Factory setting	0.0%
	Setting range	0.0%~100.0%		

26-01 monitors the car's movement position and applies a 26-01 magnitude counterforce to the motor when it exceeds the internal threshold, thereby slowing down the car's displacement speed.

26-02	Zero speed KP at shutdown		Factory setting	10
	Setting range	1~100		
26-03	Zero speed TI at shutdown		Factory setting	0.50s
	Setting range	0.01s~10.00s		

When the 0-speed function is enabled, this parameter group is combined with 02-45 and 02-46 to activate the 0-speed PI and deactivate the 0-speed PI during shutdown.

26-08	Pre-torque reduction coefficient		Factory setting	0
	Setting range	0~200		
26-09	Pre-torque enhancement coefficient		Factory setting	0
	Setting range	0~100		

26-09 The displacement velocity of the elevator car at 0 speed during startup enhances the effect of 26-00/26-26. The greater this parameter value, the stronger the enhancement effect.

During the 0-speed startup phase (26-08), when the elevator car begins moving in reverse, the 26-00 / 26-26 deceleration function activates. The higher this parameter value, the faster the deceleration effect diminishes.

26-12	FWD section speed 0 deceleration time compensation		Factory setting	0.0s
	Setting range	0.0s~600.0s		
26-13	REV section speed 0 deceleration time compensation		Factory setting	0.0s
	Setting range	0.0s~600.0s		

This parameter group applies a large compensation to the deceleration time, which is reduced to zero during shutdown, based on the direction of movement (upward or downward). The final deceleration time is therefore the deceleration time plus this compensation time.

26-14	Contact feedback detection time		Factory setting	2.00s
	Setting range	0.00s~60.00s		
26-15	Contact feedback detection selection		Factory setting	0
	Setting range	0:No detection 1:detection		
26-16	Brake feedback detection time		Factory setting	2.00s
	Setting range	0.00s~60.00s		
26-17	Brake feedback detection selection		Factory setting	0
	Setting range	0:No detection 1:detection		
26-18	Output delay		Factory setting	0.10s
	Setting range	0.00s~60.00s		
26-19	Opening brake delay		Factory setting	0.10s
	Setting range	0.00s~60.00s		
26-20	Start delay		Factory setting	0.10s
	Setting range	0.00s~60.00s		
26-21	Shutdown and closing brake frequency		Factory setting	0.00Hz
	Setting range	0.00Hz~Max.frequency (00-03)		

26-22	Closing brake delay		Factory setting	0.10s
	Setting range	0.00s~60.00s		
26-23	Shutdown delay		Factory setting	0.10s
	Setting range	0.00s~60.00s		
26-24	Contactorm turn off delay		Factory setting	0.10s
	Setting range	0.00s~60.00s		

Closed loop contactor and brake output operation timing diagram:

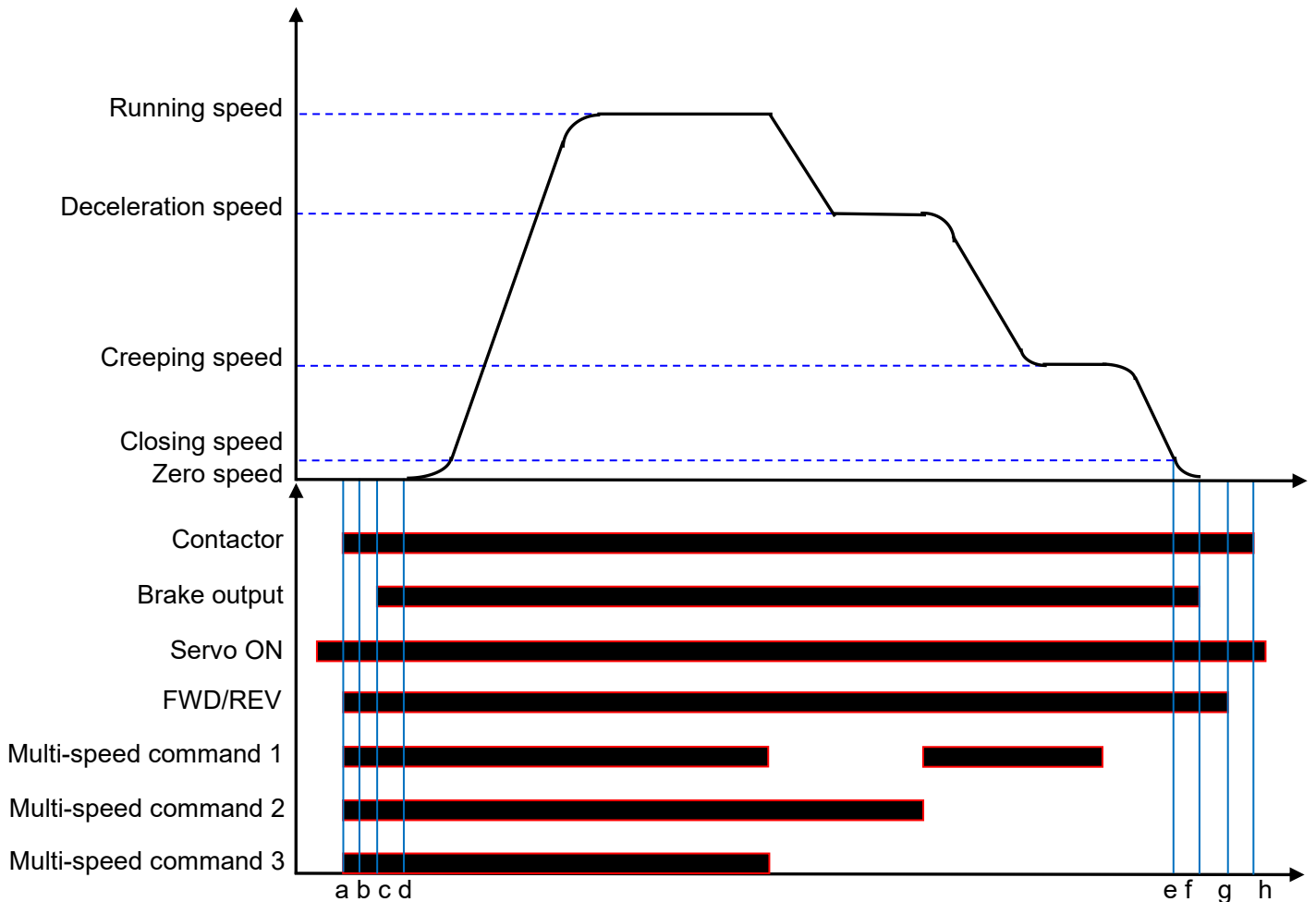

- a: Controller start signal (given direction signal), contactor output
- a ->b: After output delay (26-18), the output segment speed is 0
- b ->c: After a delay in opening (26-19), the opening output
- c ->d: After a startup delay (26-20), run according to the segment speed command
- d ->f: Normal segment speed operation, run according to segment speed instructions
- e: When the controller disconnects the given segment speed (segment speed 0), the given frequency is less than the shutdown closing frequency (26-21)
- e ->f: After a closing delay (26-22), proceed with closing
- g: Controller shutdown signal (direction signal removed)
- g ->h: After a contactor closing delay (26-23), the contactor output is closed

99 Monitoring Parameters

The 99 parameter group is used to monitor the running status information of the inverter. The user can view it through the operation panel, or read the value of the parameter group through communication in order to view the data on the spot or monitor the data of the host computer. Among them, 99-00 to 99-31 are the same as the monitoring parameters defined in 08-03/08-04.

See the table below for details.

Parameter	Name	Unit
99-00	Running frequency(Hz)	0.01Hz
99-01	Setting frequency(Hz)	0.01Hz
99-02	Bus voltage(V)	0.1V
99-03	Output voltage(V)	1V
99-04	Output current(A)	0.01A
99-05	Output power(kW)	0.1kW
99-06	Output torque(%)	0.1%
99-07	MI Input status	1
99-08	MO Output status	1
99-09	AVI1 Voltage(V)	0.01V
99-10	AVI2/ACI Voltage(V)	0.01V
99-14	Load speed	1
99-19	Feedback speed(Unit 0.1Hz)	0.1Hz
99-20	Remaining running time	0.1Min
99-21	AVI1 voltage before calibration	0.001V
99-22	AVI2/ACI voltage before calibration	0.001V
99-25	Current power-on time	1Min
99-26	Current running time	0.1Min
99-28	Communication setting value	0.01%
99-29	Encoder feedback frequency	0.01Hz
99-30	Main frequency X display	0.01Hz
99-31	Auxiliary frequency Y display	0.01Hz
99-32	View any memory address value	1
99-38	Encoder AB pulse	1
99-39	V/f separation target voltage	1V
99-40	V/f separation output voltage	1V
99-41	Visual display of MI input status	1
99-42	Visual display of MO input status	1
99-43	MI function status visual display 1	1
99-44	MI function status visual display 2	1
99-61	Inverter status	1
99-62	Fault code	1
99-63	Number of AB pulses during the 0-speed startup phase	1
99-64	Sine and Cosine CD difference	1
99-78	Start the 0-speed phase movement of the AB phase cumulative value	1
99-88	Elevator operating status	1

6 TROUBLE SHOOTING

AC motor drive is provided with functions of warning and protection such as over voltage, low voltage and over current. Once fault occurs, protection function shall act, AC motor drive output stop, fault contactor act and also free running of motor shall stop. For causes and corrective measures of fault, display of fault shall be taken for reference. The alarm records will be stored into the computer memory of AC motor driver. Attention shall be paid that RESET key, would be available only after the fault has been eliminated.

6.1 Failures & Failure Elimination

Display	Description	Possible reason	Corrective-measures
SC	Short circuit fault	<ol style="list-style-type: none"> 1. Accelerate too fast. 2. Internal damage of IGBT. 3. Malfunction caused by interference. 4. Whether the grounding is good. 	<ol style="list-style-type: none"> 1. Increase acceleration time. 2. Seek support. 3. Check whether the peripheral equipment has a strong interference source.
oc 1	Overcurrent during acceleration	<ol style="list-style-type: none"> 1. Accelerate too fast. 2. The input power voltage is low. 3. The power of the inverter is too small. 4. No parameter learning is performed during vector control. 5. Manual torque boost or V/f curve is not suitable. 6. The motor is rotating when starting. 7. There is a short circuit in the inverter output circuit. 	<ol style="list-style-type: none"> 1. Increase the acceleration time. 2. Check the input power. 3. Select a inverter with a higher power. 4. Perform parameter self-learning. 5. Adjust manual lifting torque or V/f curve. 6. Choose speed tracking or start after the motor stops. 7. Eliminate peripheral faults.
oc 2	Overcurrent during deceleration	<ol style="list-style-type: none"> 1. Decelerate too fast. 2. Large load inertia torque. 3. The power of the inverter is too small. 4. No parameter learning is performed during vector control. 5. There is a short circuit in the inverter output circuit. 	<ol style="list-style-type: none"> 1. Increase the deceleration time. 2. Add appropriate energy consumption brake components. 3. Select a frequency converter with a higher power. 4. Perform parameter self-learning. 5. Eliminate peripheral faults.
oc 3	Overcurrent at constant speed	<ol style="list-style-type: none"> 1. Abrupt or abnormal load. 2. The input power voltage is low. 3. The power of the inverter is too small. 4. No parameter learning is performed during vector control. 5. There is a short circuit in the inverter output circuit. 	<ol style="list-style-type: none"> 1. Check the load or reduce the sudden change of load. 2. Check the input power. 3. Select a frequency converter with a higher power. 4. Perform parameter self-learning. 5. Eliminate peripheral faults.
ou 1	Overvoltage during acceleration	<ol style="list-style-type: none"> 1. The input voltage is abnormal. 2. After a momentary power failure, restart the rotating motor. 	<ol style="list-style-type: none"> 1. Check the input power. 2. Avoid restarting after stopping.
ou 2	Overvoltage during deceleration	<ol style="list-style-type: none"> 1. Decelerate too fast. 2. Large load inertia. 3. The input voltage is abnormal. 	<ol style="list-style-type: none"> 1. Increase the deceleration time. 2. Increase energy consumption brake components. 3. Check the input power.
ou 3	Overvoltage at constant speed	<ol style="list-style-type: none"> 1. Abnormal changes in input voltage. 2. The load inertia is large. 	<ol style="list-style-type: none"> 1. Install input reactor. 2. Plus suitable energy consumption brake components.
uv	BUS undervoltage	<ol style="list-style-type: none"> 1. The input power supply voltage is low. 2. Instant power outage. 3. The circuit board is abnormal. 	<ol style="list-style-type: none"> 1. Check the input power 2. Reset fault 3. Seek service

Display	Description	Possible reason	Corrective-measures
OL2	Inverter overload	<ol style="list-style-type: none"> 1. Accelerate too fast. 2. Restart the rotating motor. 3. The input power voltage is too low. 4. The load is too large. 	<ol style="list-style-type: none"> 1. Increase the acceleration time. 2. Avoid restarting after shutdown. 3. Check the input power voltage 4. Select the inverter with higher power.
OL1	Motor overload	<ol style="list-style-type: none"> 1. The input power voltage is too low. 2. The motor rated current is set incorrectly. 3. The motor is blocked or the load mutation is too large. 4. Motor overloaded. 	<ol style="list-style-type: none"> 1. Check the input power voltage. 2. Reset the rated current of the motor. 3. Check the load and adjust the torque boost. 4. Choose the right motor.
OL3	Motor overload 2	<ol style="list-style-type: none"> 1. The motor is blocked or the load is too large. 2. Improper setting of protection parameters. 	<ol style="list-style-type: none"> 1. Check the load. 2. Set appropriate protection parameters.
SP1	Input phase loss	R/L1,S/L2,T/L3 Input phase loss	<ol style="list-style-type: none"> 1. Check the input power. 2. Check the installation wiring.
SP0	Output phase loss	U/T1,V/T2,W/T3 phase loss on output side (or the load three-phase is severely asymmetric)	<ol style="list-style-type: none"> 1. Check the output wiring. 2. Check the motor and cable
OH2	Module overheat	<ol style="list-style-type: none"> 1. Inverter overcurrent instantly. 2. The output three phases have interphase or ground short circuit. 3. The air duct is blocked or the fan is damaged. 4. The ambient temperature is too high. 5. Loose connection of control board or plug-in. 6. The auxiliary power supply is damaged, and the driving voltage is undervoltage. 7. Power module bridge arm is straight through. 8. The control board is abnormal. 	<ol style="list-style-type: none"> 1. See overcurrent countermeasures. 2. Rewiring. 3. Ventilate channels or replace fans. 4. Reduce the ambient temperature. 5. Check and reconnect. 6. Seek service. 7. Seek service. 8. Seek service.
EF	External fault	MI external fault input terminal action	Check external device input
CE	Communication error	<ol style="list-style-type: none"> 1. The baud rate is not set properly. 2. Communication error using serial communication. 3. Communication is interrupted for a long time. 	<ol style="list-style-type: none"> 1. Set the appropriate baud rate. 2. Press STOP/RESET button to reset and seek service. 3. Check the wiring of the communication interface.
IE	Current detection circuit fault	<ol style="list-style-type: none"> 1. Poor contact of the control board connector. 2. The auxiliary power supply is damaged. 3. The Hall device is damaged. 4. The amplifier circuit is abnormal. 	<ol style="list-style-type: none"> 1. Check the connector and reinsert the cable. 2. Search for factory maintenance. 3. Search for factory maintenance. 4. Search for factory maintenance.
SG	Motor to ground short circuit fault	Short circuit of motor to ground	Check the motor or change the cable or motor
LE	Motor auto-tuning error	<ol style="list-style-type: none"> 1. The capacity of the motor does not match the capacity of the inverter. 2. Improper setting of rated motor parameters. 3. The deviation of the self-learned parameters and the standard parameters is too large. 4. Auto-tuning timeout. 	<ol style="list-style-type: none"> 1. Replace the inverter model. 2. Set rated parameters according to the motor nameplate. 3. Make the motor empty and re-identify. 4. Check the motor wiring and parameter settings.

Display	Description	Possible reason	Corrective-measures
EEP	EEPROM reading-writing error	1.An error occurs in the reading and writing of control parameters. 2.The EEPROM is damaged.	1.Press STOP/RESE key and search for factory maintenance. 2.Search for factory maintenance
Eond	Accumulated running time reaches fault	Cumulative running time to set value	Use the parameter initialization function to clear the record information.
E ind	Accumulated power-on time reaches error	The cumulative power-on time reaches the set value.	Use the parameter initialization function to clear the record information.
oLL	Load failure	The running current of the inverter is less than 11-64.	Check whether the load or 11-64, 11-65 parameters are in accordance with the actual working conditions.
EP id	PID feedback disconnection fault	1.PID feedback disconnected. 2.The PID feedback source disappears.	1.Check the PID feedback signal line. 2.Check the PID feedback source.
CB	Wave-by-wave current limiting fault	1.Whether the load is too large or the motor stalls. 2.Inverter power is too small.	1.Reduce the load and check the motor and mechanical conditions. 2.Select the inverter with higher power.
End			Contact the service provider
EB	Charging resistor fault	Whether the input power is abnormal	Check the input power
E42	Power-on initialization abnormal	1.Whether the input power supply is abnormal. 2.The power supply or device is damaged.	1.Check the power supply. 2.Seek service.
intP	Pole position detection failed	Whether the permanent magnet synchronous motor is connected normally	Check motor connection
E46	Contact detection failure	he output of the contactor is inconsistent with the detection status	Detect related wiring
E47	Brake detection failure	The brake output and detection status are inconsistent	Detect related wiring

6.2 General troubleshooting method

Abnormal phenomenon	Check points	Processing content
The motor does not run	Has the power supply voltage been sent to R/L1, S/L2, and T/L3?	Whether the power supply is input; Turn off the power first and then send it again; Confirm the power voltage level; Whether the terminal screw is tight.
	Is there voltage output at the output terminals U/T1, V/T2, W/T3?	Turn off the power first and then send it again
	Check if the load is too heavy, causing the motor to block?	Reduce the load so that the motor can run
	Check if there is any abnormality in the inverter?	Refer to the troubleshooting instructions to deal with wiring inspection and correction
	Are forward or reverse instructions issued?	
	Check if there is an input for the analog frequency setting value?	Whether the analog frequency input signal wiring is correct; Whether the frequency input setting voltage is correct.
	Are the operating mode settings correct?	Operated by digital operation
Motor running Opposite direction	Are the output terminals U/T1, V/T2, and W/T3 wired correctly?	Must work with the U/T1,V/T2,W/T3 phase of the motor.
	Is the forward or reverse signal wiring correct?	Check and correct the wiring
Motor running Can't change speed	Is the analog frequency input wiring correct?	Check and correct the wiring
	Is the operation mode set correctly?	Operation panel operation mode setting check
	Is the load too heavy?	Lighten the load
Motor running speed is too high or too low	Is the motor specification (pole voltage) correct?	Check motor specifications
	Is the gear ratio correct?	Confirm gear ratio
	Is the maximum output frequency setting correct?	Confirm the maximum output frequency value
	Is there an extreme drop in the voltage at the motor end?	The V/f characteristic curve is set correctly
When the motor is running Abnormal speed changes	Will the load be too heavy?	Lighten the load
	Does the load change greatly?	Load fluctuation should be reduced; The capacity of the inverter and motor is increased.
	Is there any phase loss in the input power supply?	When using single-phase specifications, add AC reactor on the input power side; Check wiring when using three-phase specifications.

7 MAINTENANCE AND AMBIENT ELEMENTS

For safety and normal operation, the inverter shall be provided with daily as well as periodical maintenance.

Diagram below shows items that must be checked.

Check shall only performed 10 minutes after charging LEDs of the inverter go off, to prevent injury to operators caused by residual power of inverter condenser.

Inspection item	Inspection content	Inspection period		Inspection method	Assessment base	Corrective measures to fault
		Daily	Annual			
Machine ambient environment	Verify ambient temperature and humidity	○		Measure with temperature or humidity meter in accordance with notes for installation	Temperature:-10 to 40°C; humidity:below 95%RH	Improve environments
	Check stacking with inflammable materials	○		View inspection	No foreign materials	
Inverter installing and grounding	Check abnormal vibration to machine	○		View and auditory inspection	No foreign materials	Tighten securing screws
	Check grounding resistance complies with specification		○	Measure resistance with three-functional meter	200V Class: below 100Ω; 400V Class: below 100Ω	Modify grounding
Input power supply voltage	Check main circuit voltage	○		Measure resistance with three-functional meter	Voltage value complies with specifications	Modify input power supply
External terminal securing screws of the inverter	Check security of screwed parts		○	View inspection and check screws are secured tightly with screwdriver	All OK	Tighten or sent for factory maintenance and overhaul
	Check terminal board is not damaged		○			
	Check no clear rust exists		○			
Inverter inner wiring	Check no distortion appears		○		All OK	
	Check outer shielding is not broken		○	View inspection	All OK	Replace or sent for factory maintenance and overhaul
Radiator	Check no dust or chipping stacked	○		View inspection	All OK	Remove stacking such as dust
Printing circuit board	Check no inductive metal or oil stacked		○	View inspection	All OK	Remove or replace electric board
	Check elements are exclusive of color changing or burning due to overheat		○			
Cooling fan	Check abnormal vibration or noise		○	View inspection and auditory inspection	All OK	Replace cooling fan
	Check no dust or chipping stacked	○		View inspection		Remove
Power elements	Check no dust or chipping stacked		○	View inspection	All OK	Remove
	Check resistance between terminals		○	Check using three-functional meter	No short circuit or circuit break for three phase output	Replace power elements or inverter

Inspection item	Inspection content	Inspection period		Inspection method	Assessment base	Corrective measures to fault
		Daily	Annual			
Condenser	Check for odor or leakage	○		View inspection	All OK	Replace condenser or inverter
	Check for expansion or distortion	○				

Always inspection and maintenance is not necessary for S3100L.

For long time safety operation, periodical inspection shall be prepared to the inverter in accordance with descriptions below. Inspection shall only performed after power supply is off and charging LED off (since residual voltage may exist in the large capacity condensers.)

- 1.Remove dirty stacking inside the machine
- 2.Check screws securing terminals or elements are securely tightened; if not, tighten the screws.

7.1 Braking Resistor Selection Guide

The choice of braking resistor needs to be determined according to the power generated by the motor in the actual application system and has the relationship with the inertia of the system, the deceleration time, the energy that the bit can load, etc., and needs the customer to choose according to the actual situation. The larger the system inertia, the shorter the deceleration time required, the more frequent braking, the greater the braking resistance power to choose, the smaller the resistance, but not lower than the recommended minimum resistance.

(1) When braking, the regenerative energy of the motor is almost entirely consumed on the brake resistor.

The formula is: $U \times U / R = P_b$

U - braking voltage with stable system brake (440V-class default is DC750V, 220V-class default is DC360V)

P_b - braking power

(2) Brake resistor power selection

The power of the brake resistor is theoretically the same to the braking power, but considering the derating is 70%.

The formula is: $0.7 \times P_r = P_b \times ED$

P_r - resistance power

ED - brake rate (brake process accounts for the proportion of the entire work process)

Common occasions	Centrifuge	General brake load
Brake rate(ED)	50~60%	5%~10%

(3) Brake resistor selection calculation reference

- ① 380V5.5kW motor applications, for example, check the table below to get:10% braking resistor resistance specifications:500W100Ω, as applied to the lifting industry needs up to 30% of the braking rate, the formula between the resistance power and braking rate is in direct proportion,Therefore, the choice of resistance specifications:500W x (30% / 10%) = 1500W100Ω.
- ② If the braking torque is not enough, the test will need to use 80Ω to ensure not jump OU (inverter over-voltage), the formula that the resistance is inversely proportional to the braking power, Therefore, the new resistance specification at 10% ED is:500W x (100Ω / 80Ω) = 625W80Ω.
- ③ If the lifting load is heavy, also needs 80Ω resistor and 30% braking rate,Then the new resistance specifications:625W x (30% / 10%) = 1875W80Ω.

Braking Resistor List

Voltage	Applicable motor		Full load output torque (Nm)	Braking unit	Braking resistor	Braking torque 10%ED%	Min resistance
	HP	kW		Quantity	Quantity		
440V Series	7.5	5.5	30.46	Built-in	1500W 100Ω	125	60Ω
					1		
	10	7.5	41.54		2500W 75Ω	125	45Ω
					1		
	15	11	60.93		3000W 50Ω	125	50Ω
					1		
	20	15	83.09		4500W 40Ω	125	40Ω
					1		
	25	18.5	102.47		6000W 32Ω	125	32Ω
					1		

Notes:

- 1.Watts of voltage value and frequency applied(ED %) shall be in accordance with specifications of this company.
- 2.This company shall not be responsible for damaging of inverter or other devices, which shall be caused by braking resistor or braking module that were not produced by this company.
- 3.When installing braking resistor, great care shall be attached on safety or inflammability of the ambient environments.
- 4.In case of Min resistance shall be used, contact your SAVCH ELECTRIC for suggestion of watts calculating.

7.2 Breaker,cable and contactor specifications list

Model	Breaker(A)	Input cable/Output cable (Copper wire cable)mm ²	Contactor rated current (A)
S3100L-4T5.5G	25	4	16
S3100L-4T7.5G	40	6	25
S3100L-4T11G	63	6	32
S3100L-4T15G	63	6	50
S3100L-4T18.5G	100	10	63

7.3 Input/output AC reactor and DC reactor specifications

Model	Input AC reactor (recommended)	Output AC reactor (recommended)	DC reactor (recommended)
S3100L-4T5.5G	ACL-0015-EISC- EM93C	OCL-0015-EISC-EM47	×
S3100L-4T7.5G	ACL-0020-EISC-EM70C	OCL-0020-EISC-EM35	×
S3100L-4T11G	ACL-0030-EISCL-EM47C	OCL-0030-EISC-EM23	×
S3100L-4T15G	ACL-0040-EISCL-EM35C	OCL-0040-EISC-EM18	×
S3100L-4T18.5G	ACL-0050-EISCL-EM28C	OCL-0050-EISC-EM14	×

Note: 1. × shown that Needless or Built-in.

7.4 Input/output filter specifications

Model	Input filter specifications (recommended)	Output filter specifications (recommended)
S3100L-4T5.5G	NFI-020	NFO-020
S3100L-4T7.5G	NFI-020	NFO-020
S3100L-4T11G	NFI-036	NFO-036
S3100L-4T15G	NFI-036	NFO-036
S3100L-4T18.5G	NFI-050	NFO-050

- Innovate for more | win forever
- Industry intelligence | Energy saving | Green power

Qualification

Designed by Taiwan savch electric

Received ISO9001 and CE certificate

All rights reserved. Subject to change without further notice.