

# Control Wiring Diagram

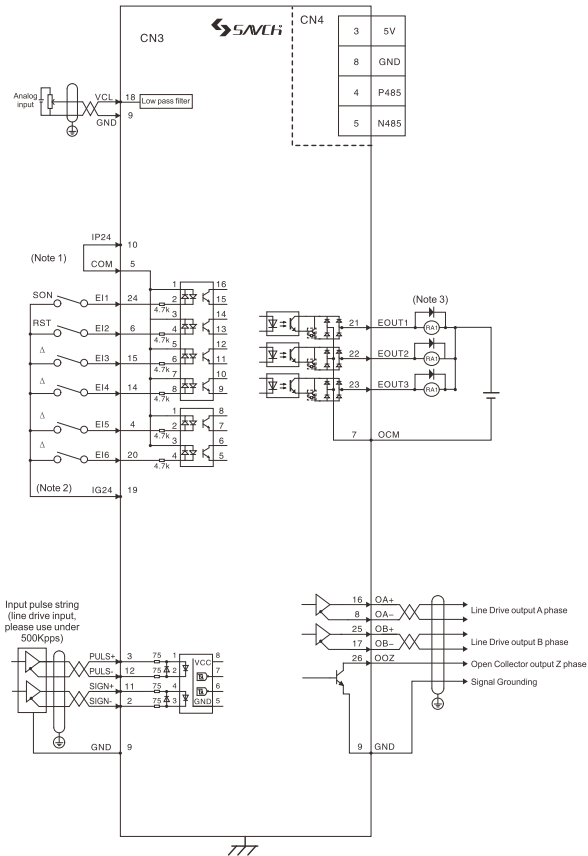
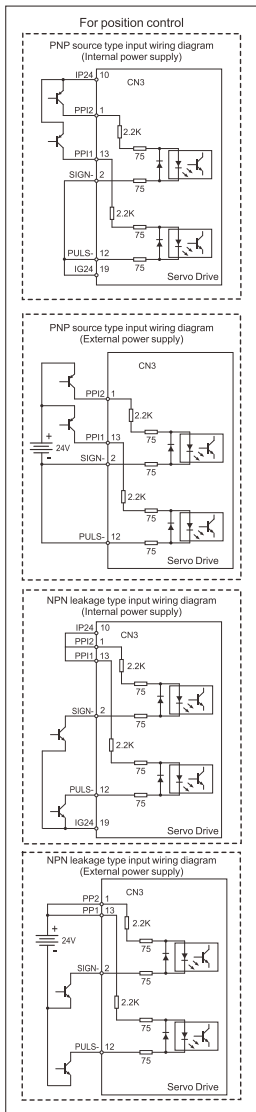

Note 1: When the external power are adopted, do not connect the COM with IP24, external power supply 24V connected to COM.

Note 2: The EI input terminal that is marked  $\Delta$  indicates that the default function is not defined, user can set the required function according to the parameter of Chapter 6.

Note 3: The diode installation direction could not be connected by the wrong way, max working voltage 24V, max output current 50mA; the current value of external relay ring should be lower than 80mA. When the current value is greater than 80mA, the power should be supplied externally.